

REVISIONS

LTR	DESCRIPTION	DATE (YR-MO-DA)	APPROVED
A	Add RHA data. Editorial changes throughout - jak.	98-05-29	Monica L. Poelking

REV																				
SHEET																				
REV	A	A	A	A	A															
SHEET	15	16	17	18	19															
REV STATUS OF SHEETS	REV		A	A	A	A	A	A	A	A	A	A	A	A	A	A	A	A	A	
	SHEET		1	2	3	4	5	6	7	8	9	10	11	12	13	14				

PMIC N/A	PREPARED BY Wanda L. Meadows	DEFENSE SUPPLY CENTER COLUMBUS																	
STANDARD MICROCIRCUIT DRAWING THIS DRAWING IS AVAILABLE FOR USE BY ALL DEPARTMENTS AND AGENCIES OF THE DEPARTMENT OF DEFENSE AMSC N/A	CHECKED BY Thomas J. Ricciuti	COLUMBUS, OHIO 43216																	
	APPROVED BY Monica L. Poelking	MICROCIRCUITS, DIGITAL, ADVANCED CMOS, OCTAL BIDIRECTIONAL TRANSCEIVER WITH THREE-STATE INPUTS/OUTPUTS, TTL COMPATIBLE, MONOLITHIC SILICON																	
	DRAWING APPROVAL DATE 93-04-09	SIZE A	CAGE CODE 67268	5962-92187															
	REVISION LEVEL A	SHEET		1 OF 19															

1. SCOPE

1.1 Scope. This drawing documents two product assurance class levels consisting of high reliability (device classes Q and M) and space application (device class V). A choice of case outlines and lead finishes are available and are reflected in the Part or Identifying Number (PIN). When available, a choice of Radiation Hardness Assurance (RHA) levels are reflected in the PIN.

1.2 PIN. The PIN is as shown in the following example:

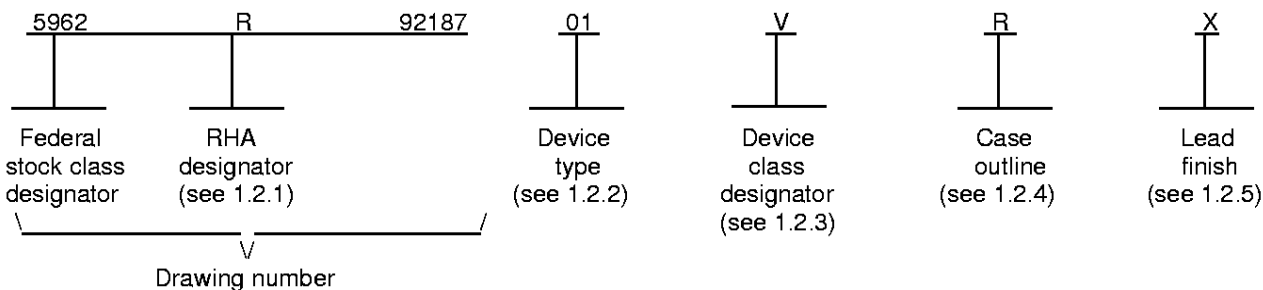

1.2.1 RHA designator. Device classes Q and V RHA marked devices meet the MIL-PRF-38535 specified RHA levels and are marked with the appropriate RHA designator. Device class M RHA marked devices meet the MIL-PRF-38535, appendix A specified RHA levels and are marked with the appropriate RHA designator. A dash (-) indicates a non-RHA device.

1.2.2 Device type(s). The device type(s) identify the circuit function as follows:

<u>Device type</u>	<u>Generic number</u>	<u>Circuit function</u>
01	54ACTQ245	Octal bidirectional transceiver with three-state inputs/outputs, TTL compatible inputs

1.2.3 Device class designator. The device class designator is a single letter identifying the product assurance level as follows:

<u>Device class</u>	<u>Device requirements documentation</u>
M	Vendor self-certification to the requirements for MIL-STD-883 compliant, non-JAN class level B microcircuits in accordance with MIL-PRF-38535, appendix A
Q or V	Certification and qualification to MIL-PRF-38535

1.2.4 Case outline(s). The case outline(s) are as designated in MIL-STD-1835 and as follows:

<u>Outline letter</u>	<u>Descriptive designator</u>	<u>Terminals</u>	<u>Package style</u>
R	GDIP1-T20 or CDIP2-T20	20	Dual-in-line
S	GDFP2-F20 or CDFP3-F20	20	Flat pack
2	CQCC1-N20	20	Square leadless chip carrier

1.2.5 Lead finish. The lead finish is as specified in MIL-PRF-38535 for device classes Q and V or MIL-PRF-38535, appendix A for device class M.

STANDARD MICROCIRCUIT DRAWING DEFENSE SUPPLY CENTER COLUMBUS COLUMBUS, OHIO 43216-5000	SIZE A		5962-92187
		REVISION LEVEL A	SHEET 2

1.3 Absolute maximum ratings. 1/ 2/ 3/

Supply voltage range (V_{CC}).....	-0.5 V dc to +7.0 V dc
DC input voltage range (V_{IN}).....	-0.5 V dc to $V_{CC} + 0.5$ V dc
DC output voltage range (V_{OUT}).....	-0.5 V dc to $V_{CC} + 0.5$ V dc
DC input clamp current (I_{IK}) ($V_{IN} = -0.5$ V and $V_{CC} + 0.5$ V).....	± 20 mA
DC output clamp current (I_{OK}) ($V_{OUT} = -0.5$ V and $V_{CC} + 0.5$ V).....	± 20 mA
DC output current (I_{OUT}) per output pin.....	± 50 mA
DC V_{CC} or GND current (I_{CC} , I_{GND}) per pin.....	± 400 mA
Maximum power dissipation (P_D).....	500 mW
Storage temperature range (T_{STG}).....	-65°C to +150°C
Lead temperature (soldering, 10 seconds).....	+300°C
Thermal resistance, junction-to-case (θ_{JC}).....	See MIL-STD-1835
Junction temperature (T_J).....	+175°C 4/

1.4 Recommended operating conditions. 2/ 3/

Supply voltage range (V_{CC}).....	+4.5 V dc to +5.5 V dc
Input voltage range (V_{IN}).....	+0.0 V dc to V_{CC}
Output voltage range (V_{OUT}).....	+0.0 V dc to V_{CC}
Maximum low level input voltage (V_{IL}).....	0.8 V dc
Minimum high level input voltage (V_{IH}).....	2.0 V dc
Case operating temperature range (T_C).....	-55°C to +125°C
Input rise or fall times ($V_{CC} = 4.5$ V to 5.5 V).....	0 to 8 ns/V
Maximum high level output current (I_{OH}).....	-24 mA
Maximum low level output current (I_{OL}).....	+24 mA

1.5 Digital logic testing for device classes Q and V.

Fault coverage measurement of manufacturing logic tests (MIL-STD-883, test method 5012) XX percent 5/

- 1/ Stresses above the absolute maximum rating may cause permanent damage to the device. Extended operation at the maximum levels may degrade performance and affect reliability.
- 2/ Unless otherwise noted, all voltages are referenced to GND.
- 3/ The limits for the parameters specified herein shall apply over the full specified V_{CC} range and case temperature range of -55°C to +125°C.
- 4/ Maximum junction temperature shall not be exceeded except for allowable short duration burn-in screening conditions in accordance with method 5004 of MIL-STD-883.
- 5/ Values will be added when they become available from the qualified source.

STANDARD MICROCIRCUIT DRAWING DEFENSE SUPPLY CENTER COLUMBUS COLUMBUS, OHIO 43216-5000	SIZE A	5962-92187
	REVISION LEVEL A	SHEET 3

2. APPLICABLE DOCUMENTS

2.1 Government specification, standards, and handbooks. The following specification, standards, and handbooks form a part of this drawing to the extent specified herein. Unless otherwise specified, the issues of these documents are those listed in the issue of the Department of Defense Index of Specifications and Standards (DoDISS) and supplement thereto, cited in the solicitation.

SPECIFICATION

DEPARTMENT OF DEFENSE

MIL-PRF-38535 - Integrated Circuits, Manufacturing, General Specification for.

STANDARDS

DEPARTMENT OF DEFENSE

- MIL-STD-883 - Test Method Standard Microcircuits.
- MIL-STD-973 - Configuration Management.
- MIL-STD-1835 - Interface Standard For Microcircuit Case Outlines.

HANDBOOKS

DEPARTMENT OF DEFENSE

- MIL-HDBK-103 - List of Standard Microcircuit Drawings (SMD's).
- MIL-HDBK-780 - Standard Microcircuit Drawings.

(Unless otherwise indicated, copies of the specification, standards, and handbooks are available from the Standardization Document Order Desk, 700 Robbins Avenue, Building 4D, Philadelphia, PA 19111-5094.)

2.2 Non-Government publications. The following document(s) form a part of this document to the extent specified herein. Unless otherwise specified, the issues of the documents which are DOD adopted are those listed in the issue of the DODISS cited in the solicitation. Unless otherwise specified, the issues of documents not listed in the DODISS are the issues of the documents cited in the solicitation.

ELECTRONIC INDUSTRIES ASSOCIATION (EIA)

- JEDEC Standard No. 17 - A Standardized Test Procedure for the Characterization of Latch-up in CMOS Integrated Circuits
- JEDEC Standard No. 20 - Standardized for Description of 54/74ACXXXX and 54/74ACTXXXX Advanced High-Speed CMOS Devices.

(Applications for copies should be addressed to the Electronics Industries Association, 2001 Eye Street, NW, Washington, DC 20006.)

(Non-Government standards and other publications are normally available from the organizations that prepare or distribute the documents. These documents may also be available in or through libraries or other informational services.)

2.3 Order of precedence. In the event of a conflict between the text of this drawing and the references cited herein, the text of this drawing takes precedence. Nothing in this document, however, supersedes applicable laws and regulations unless a specific exemption has been obtained.

STANDARD MICROCIRCUIT DRAWING DEFENSE SUPPLY CENTER COLUMBUS COLUMBUS, OHIO 43216-5000	SIZE A		5962-92187
		REVISION LEVEL A	SHEET 4

3. REQUIREMENTS

3.1 Item requirements. The individual item requirements for device classes Q and V shall be in accordance with MIL-PRF-38535 and as specified herein or as modified in the device manufacturer's Quality Management (QM) plan. The modification in the QM plan shall not affect the form, fit, or function as described herein. The individual item requirements for device class M shall be in accordance with MIL-PRF-38535, appendix A for non-JAN class level B devices and as specified herein.

3.2 Design, construction, and physical dimensions. The design, construction, and physical dimensions shall be as specified in MIL-PRF-38535 and herein for device classes Q and V or MIL-PRF-38535, appendix A and herein for device class M.

3.2.1 Case outlines. The case outlines shall be in accordance with 1.2.4 herein.

3.2.2 Terminal connections. The terminal connections shall be as specified on figure 1.

3.2.3 Truth table. The truth table shall be as specified on figure 2.

3.2.4 Logic diagram. The logic diagram shall be as specified on figure 3.

3.2.5 Ground bounce load circuit and waveforms. The ground bounce load circuit and waveforms shall be as specified on figure 4.

3.2.6 Switching waveforms and test circuit. The switching waveforms and test circuit shall be as specified on figure 5.

3.2.7 Radiation exposure circuit. The radiation exposure circuit shall be as specified when available.

3.3 Electrical performance characteristics and postirradiation parameter limits. Unless otherwise specified herein, the electrical performance characteristics and postirradiation parameter limits are as specified in table I and shall apply over the full case operating temperature range.

3.4 Electrical test requirements. The electrical test requirements shall be the subgroups specified in table II. The electrical tests for each subgroup are defined in table I.

3.5 Marking. The part shall be marked with the PIN listed in 1.2 herein. In addition, the manufacturer's PIN may also be marked as listed in MIL-HDBK-103. For packages where marking of the entire SMD PIN number is not feasible due to space limitations, the manufacturer has the option of not marking the "5962-" on the device. For RHA product using this option, the RHA designator shall still be marked. Marking for device classes Q and V shall be in accordance with MIL-PRF-38535. Marking for device class M shall be in accordance with MIL-PRF-38535, appendix A.

3.5.1 Certification/compliance mark. The certification mark for device classes Q and V shall be a "QML" or "Q" as required in MIL-PRF-38535. The compliance mark for device class M shall be a "C" as required in MIL-PRF-38535, appendix A.

3.6 Certificate of compliance. For device classes Q and V, a certificate of compliance shall be required from a QML-38535 listed manufacturer in order to supply to the requirements of this drawing (see 6.6.1 herein). For device class M, a certificate of compliance shall be required from a manufacturer in order to be listed as an approved source of supply in MIL-HDBK-103 (see 6.6.2 herein). The certificate of compliance submitted to DSCC-VA prior to listing as an approved source of supply for this drawing shall affirm that the manufacturer's product meets, for device classes Q and V, the requirements of MIL-PRF-38535 and herein or for device class M, the requirements of MIL-PRF-38535, appendix A and herein.

3.7 Certificate of conformance. A certificate of conformance as required for device classes Q and V in MIL-PRF-38535 or for device class M in MIL-PRF-38535, appendix A shall be provided with each lot of microcircuits delivered to this drawing.

3.8 Notification of change for device class M. For device class M, notification to DSCC-VA of change of product (see 6.2 herein) involving devices acquired to this drawing is required for any change as defined in MIL-STD-973.

STANDARD MICROCIRCUIT DRAWING DEFENSE SUPPLY CENTER COLUMBUS COLUMBUS, OHIO 43216-5000	SIZE A		5962-92187
		REVISION LEVEL A	SHEET 5

3.9 Verification and review for device class M. For device class M, DSCC, DSCC's agent, and the acquiring activity retain the option to review the manufacturer's facility and applicable required documentation. Offshore documentation shall be made available onshore at the option of the reviewer.

3.10 Microcircuit group assignment for device class M. Device class M devices covered by this drawing shall be in microcircuit group number 37 (see MIL-PRF-38535, appendix A).

4. QUALITY ASSURANCE PROVISIONS

4.1 Sampling and inspection. For device classes Q and V, sampling and inspection procedures shall be in accordance with MIL-PRF-38535 or as modified in the device manufacturer's Quality Management (QM) plan. The modification in the QM plan shall not affect the form, fit, or function as described herein. For device class M, sampling and inspection procedures shall be in accordance with MIL-PRF-38535, appendix A.

4.2 Screening. For device classes Q and V, screening shall be in accordance with MIL-PRF-38535, and shall be conducted on all devices prior to qualification and technology conformance inspection. For device class M, screening shall be in accordance with method 5004 of MIL-STD-883, and shall be conducted on all devices prior to quality conformance inspection.

4.2.1 Additional criteria for device class M.

- a. Burn-in test, method 1015 of MIL-STD-883.
 - (1) Test condition A, B, C, or D. The test circuit shall be maintained by the manufacturer under document revision level control and shall be made available to the preparing or acquiring activity upon request. The test circuit shall specify the inputs, outputs, biases, and power dissipation, as applicable, in accordance with the intent specified in test method 1015.
 - (2) T_A = +125°C, minimum.
- b. Interim and final electrical test parameters shall be as specified in table II herein.

4.2.2 Additional criteria for device classes Q and V.

- a. The burn-in test duration, test condition and test temperature, or approved alternatives shall be as specified in the device manufacturer's QM plan in accordance with MIL-PRF-38535. The burn-in test circuit shall be maintained under document revision level control of the device manufacturer's Technology Review Board (TRB) in accordance with MIL-PRF-38535 and shall be made available to the acquiring or preparing activity upon request. The test circuit shall specify the inputs, outputs, biases, and power dissipation, as applicable, in accordance with the intent specified in test method 1015 of MIL-STD-883.
- b. Interim and final electrical test parameters shall be as specified in table II herein.
- c. Additional screening for device class V beyond the requirements of device class Q shall be as specified in MIL-PRF-38535, appendix B.

4.3 Qualification inspection for device classes Q and V. Qualification inspection for device classes Q and V shall be in accordance with MIL-PRF-38535. Inspections to be performed shall be those specified in MIL-PRF-38535 and herein for groups A, B, C, D, and E inspections (see 4.4.1 through 4.4.4).

STANDARD MICROCIRCUIT DRAWING DEFENSE SUPPLY CENTER COLUMBUS COLUMBUS, OHIO 43216-5000	SIZE A		5962-92187
		REVISION LEVEL A	SHEET 6

Table I. Electrical performance characteristics.

Test and MIL-STD-883 test method <u>1/</u>	Symbol	Test conditions <u>2/</u> -55°C ≤ T _C ≤ +125°C +4.5 V ≤ V _{CC} ≤ +5.5 V unless otherwise specified	Device type and Device class	V _{CC}	Group A subgroups	Limits <u>3/</u>		Unit
						Min	Max	
High level output voltage 3006	V _{OH} <u>4/ 5/</u>	For all inputs affecting output under test, V _{IN} = 2.0 V or 0.8 V For all other inputs, V _{IN} = V _{CC} or GND I _{OH} = -50 μA	M, D, L, R	All All	4.5 V	1, 2, 3	4.4	V
				All All	5.5 V	1, 2, 3	5.4	
				All All	5.5 V	1	5.4	
				All All	4.5 V	1	3.86	
				All All	4.5 V	1	3.86	
				All All	4.5 V	2, 3	3.7	
		For all inputs affecting output under test, V _{IN} = 2.0 V or 0.8 V For all other inputs, V _{IN} = V _{CC} or GND I _{OH} = -24 mA		All All	5.5 V	1	4.86	
				All All	5.5 V	2, 3	4.7	
				All All	5.5 V	1, 2, 3	3.85	
				All All	5.5 V	1	3.85	
				All All	4.5 V	1	0.1	
				All All	5.5 V	1, 2, 3	0.1	
Low level output voltage 3007	V _{OL} <u>4/ 5/</u>	For all inputs affecting output under test, V _{IN} = 2.0 V or 0.8 V For all other inputs, V _{IN} = V _{CC} or GND I _{OL} = 50 μA	M, D, L, R	All All	4.5 V	1, 2, 3	0.1	V
				All All	5.5 V	1, 2, 3	0.1	
				All All	5.5 V	1	0.1	
				All All	4.5 V	1	0.36	
				All All	4.5 V	1	0.36	
				All All	4.5 V	2, 3	0.5	
		For all inputs affecting output under test, V _{IN} = 2.0 V or 0.8 V For all other inputs, V _{IN} = V _{CC} or GND I _{OL} = 24 mA		All All	5.5 V	1	0.36	
				All All	5.5 V	2, 3	0.5	
				All All	5.5 V	1, 2, 3	1.65	
				All All	5.5 V	1	1.65	
				All All	4.5 V	1	0.1	
				All All	5.5 V	1, 2, 3	0.1	

See footnotes at end of table.

STANDARD MICROCIRCUIT DRAWING DEFENSE SUPPLY CENTER COLUMBUS COLUMBUS, OHIO 43216-5000	SIZE A		5962-92187
		REVISION LEVEL A	SHEET 7

Table I. Electrical performance characteristics - Continued.

Test and MIL-STD-883 test method <u>1/</u>	Symbol	Test conditions <u>2/</u> -55°C ≤ T _C ≤ +125°C +4.5 V ≤ V _{CC} ≤ +5.5 V unless otherwise specified	Device type and Device class	V _{CC}	Group A subgroups	Limits <u>3/</u>		Unit	
						Min	Max		
Positive input clamp voltage 3022	V _{IC+} <u>4/ 5/</u>	For input under test, I _{IN} = 18 mA	All All	4.5 V	1, 2, 3		5.7	V	
			M, D, L, R	All All	4.5 V	1			5.7
Negative input clamp voltage 3022	V _{IC-} <u>4/ 5/</u>	For input under test, I _{IN} = -18 mA	All All	4.5 V	1, 2, 3		-1.2	V	
			M, D, L, R	All All	4.5 V	1			-1.2
Input leakage current high 3010	I _{IH} <u>4/ 5/</u>	For input under test, V _{IN} = 5.5 V For all other inputs, V _{IN} = V _{CC} or GND	All All	5.5 V	1		0.1	μA	
			M, D, L, R	All All	5.5 V	1			1.0
				All All	5.5 V	2, 3			1.0
Input leakage current low 3009	I _{IL} <u>4/ 5/</u>	For input under test, V _{IN} = 0.0 V For all other inputs, V _{IN} = V _{CC} or GND	All All	5.5 V	1		-0.1	μA	
			M, D, L, R	All All	5.5 V	1			-1.0
				All All	5.5 V	2, 3			-1.0
Three-state output leakage current high 3021	I _{OZH} <u>4/ 5/ 7/</u>	OE = 2.0 V For all other inputs, V _{IN} = V _{CC} or GND V _{OUT} = 5.5 V	All All	5.5 V	1		0.5	μA	
			M, D, L, R	All All	5.5 V	1			25.0
				All All	5.5 V	2, 3			10.0
Three-state output leakage current low 3020	I _{OZL} <u>4/ 5/ 7/</u>	OE = 2.0 V For all other inputs, V _{IN} = V _{CC} or GND V _{OUT} = 0.0 V	All All	5.5 V	1		-0.5	μA	
			M, D, L, R	All All	5.5 V	1			-25.0
				All All	5.5 V	2, 3			-10.0
Quiescent supply current, output high 3005	I _{CCH} <u>4/ 5/</u>	OE = GND For all other inputs, V _{IN} = V _{CC} or GND	All All	5.5 V	1		8.0	μA	
					5.5 V	2, 3			160
			M	All	5.5 V	1			100
			D	All					1.0
							3.5	mA	

See footnotes at end of table.

STANDARD MICROCIRCUIT DRAWING DEFENSE SUPPLY CENTER COLUMBUS COLUMBUS, OHIO 43216-5000	SIZE A		5962-92187
		REVISION LEVEL A	SHEET 8

Table I. Electrical performance characteristics - Continued.

Test and MIL-STD-883 test method <u>1/</u>	Symbol	Test conditions <u>2/</u> -55°C ≤ T _C ≤ +125°C +4.5 V ≤ V _{CC} ≤ +5.5 V unless otherwise specified	Device type and Device class	V _{CC}	Group A subgroups	Limits <u>3/</u>		Unit
						Min	Max	
Quiescent supply current, output low 3005	I _{CC(L)} <u>4/ 5/</u>	OE = GND For all other inputs, V _{IN} = V _{CC} or GND	All	5.5 V	1		8.0	μA
			All			2, 3		
			M	5.5 V	1		100	mA
			D				1.0	
L, R		3.5						
Quiescent supply current, output three-state 3005	I _{CC(Z)} <u>4/ 5/ 7/</u>	OE = V _{CC} For all other inputs, V _{IN} = V _{CC} or GND	All	5.5 V	1		8.0	μA
			All			2, 3		
			M	5.5 V	1		100	mA
			D				1.0	
L, R		3.5						
Quiescent supply current delta, TTL input level 3005	ΔI _{CC} <u>4/ 5/ 8/</u>	For input under test, V _{IN} = V _{CC} - 2.1 V For all other inputs, V _{IN} = V _{CC} or GND	All	5.5 V	1		1.0	mA
			All			2, 3		
			M, D	5.5 V	1		1.6	mA
			L, R				3.5	
Input capacitance 3012	C _{IN}	See 4.4.1d T _C = +25°C	All All	GND	4		10.0	pF
Output capacitance 3012	C _{OUT} <u>7/</u>	See 4.4.1d T _C = +25°C	All All	5.5 V	4		15.0	pF
Power dissipation capacitance	C _{PD} <u>9/</u>	See 4.4.1d T _C = +25°C	All All	5.0 V	4		80	pF
Low level ground bounce noise	V _{OLP} <u>10/</u>	VIH = 3.0 V, VIL = 0.0 V T _A = +25°C See 4.4.1c See figure 4	All All	5.0 V	4		1650	mV
	V _{OLV} <u>10/</u>		All All				-1200	
High level V _{CC} bounce noise	V _{OHP} <u>10/</u>		All All	5.0 V	4		V _{OH} +1000	mV
	V _{OHV} <u>10/</u>		All All				V _{OH} -1800	
Latch-up input/output over-voltage	I _{CC} (O/V1) <u>11/</u>	t _w ≥ 100 μs, t _{cool} ≥ t _w 5 μs ≤ t _r ≤ 5 ms 5 μs ≤ t _f ≤ 5 ms V _{test} = 6.0 V V _{CCQ} = 5.5 V V _{over} = 10.5 V	All Q, V	5.5 V	2		200	mA
Latch-up input/output positive over-current	I _{CC} (O/I1+) <u>11/</u>	t _w ≥ 100 μs, t _{cool} ≥ t _w 5 μs ≤ t _r ≤ 5 ms 5 μs ≤ t _f ≤ 5 ms V _{test} = 6.0 V V _{CCQ} = 5.5 V I _{trigger} = +120 mA	All Q, V	5.5 V	2		200	mA

See footnotes at end of table.

STANDARD MICROCIRCUIT DRAWING DEFENSE SUPPLY CENTER COLUMBUS COLUMBUS, OHIO 43216-5000	SIZE A		5962-92187
		REVISION LEVEL A	SHEET 9

Table I. Electrical performance characteristics - Continued.

Test and MIL-STD-883 test method <u>1/</u>	Symbol	Test conditions <u>2/</u> -55°C ≤ T _C ≤ +125°C +4.5 V ≤ V _{CC} ≤ +5.5 V unless otherwise specified	Device type and Device class	V _{CC}	Group A subgroups	Limits <u>3/</u>		Unit		
						Min	Max			
Latch-up input/output negative over-current	I _{CC} (O/I1-) <u>11/</u>	t _w ≥ 100 μs, t _{cool} ≥ t _w 5 μs ≤ t _r ≤ 5 ms 5 μs ≤ t _f ≤ 5 ms V _{test} = 6.0 V V _{CCQ} = 5.5 V I _{trigger} = -120 mA	All Q, V	5.5 V	2		200	mA		
Latch-up supply over-voltage	I _{CC} (O/V2) <u>11/</u>	t _w ≥ 100 μs, t _{cool} ≥ t _w 5 μs ≤ t _r ≤ 5 ms 5 μs ≤ t _f ≤ 5 ms V _{test} = 6.0 V V _{CCQ} = 5.5 V V _{over} = 9.0 V	All Q, V	5.5 V	2		100	mA		
Functional tests 3014	<u>4/ 5/</u> <u>12/</u>	V _{IH} = 2.4 V, V _{IL} = 0.4 V Verify output V _{OUT} See 4.4.1e	All	4.5 V	7, 8	L	H			
			M, D, L, R			All	7	L	H	
			All			All	5.5 V	7, 8	L	H
Propagation delay time, data to output, A _n to B _n , B _n to A _n 3003	t _{PHL} t _{PLH} <u>4/ 5/</u> <u>13/</u>	C _L = 50 pF minimum R _L = 500Ω See figure 5	All	4.5 V	9	1.0	8.0	ns		
			M, D, L, R			All	9		1.0	8.0
			All			All	10, 11		1.0	9.0
Propagation delay time, output enable, OE to A _n , B _n 3003	t _{PZH} t _{PZL} <u>4/ 5/</u> <u>13/</u>	C _L = 50 pF minimum R _L = 500Ω See figure 5	All	4.5 V	9	1.0	11.0	ns		
			M, D, L, R			All	9		1.0	11.0
			All			All	10, 11		1.0	12.0
Propagation delay time, output disable, OE to A _n , B _n 3003	t _{PHZ} t _{PLZ} <u>4/ 5/</u> <u>13/</u>	C _L = 50 pF minimum R _L = 500Ω See figure 5	All	4.5 V	9	1.0	10.0	ns		
			M, D, L, R			All	9		1.0	10.0
			All			All	10, 11		1.0	11.5

1/ For tests not listed in the referenced MIL-STD-883, (e.g. ΔI_{CC}), utilize the general test procedure under the conditions listed herein. All inputs and outputs shall be tested, as applicable, to the tests in table I herein.

2/ Each input/output, as applicable, shall be tested at the specified temperature, for the specified limits. The V_{IH} minimum and V_{IL} maximum thresholds for any input that may affect the logic state of the output under test shall be verified during each V_{OL} and V_{OH} test. On some devices, this will require repeating the same V_{OL} and V_{OH} tests multiple times to verify all input thresholds. Output terminals not designated shall be high level logic, low level logic, or open, except for the I_{CC} and ΔI_{CC} tests, the output terminal shall be open. When performing the I_{CC} and ΔI_{CC} tests, the current meter shall be placed in the circuit such that all current flows through the meter.

Additional detailed information on qualified devices (i.e. pin for pin conditions and testing sequence) is available from the qualifying activity (DCSS-VQC) upon request.

STANDARD MICROCIRCUIT DRAWING DEFENSE SUPPLY CENTER COLUMBUS COLUMBUS, OHIO 43216-5000	SIZE A		5962-92187
		REVISION LEVEL A	SHEET 10

Table I. Electrical performance characteristics - Continued.

- 3/ For negative and positive voltage and current values, the sign designates the potential difference in reference to GND and the direction of current flow, respectively; and the absolute value of the magnitude, not the sign, is relative to the minimum and maximum limits, as applicable, listed herein. All devices shall meet or exceed the limits specified in table I, as applicable, at $+4.5 \text{ V} \leq V_{CC} \leq +5.5 \text{ V}$.
- 4/ RHA samples do not have to be tested at -55°C and $+125^\circ\text{C}$ prior to irradiation.
- 5/ When performing post irradiation electrical measurements for RHA level, $T_A = +25^\circ\text{C}$. Limits shown are guaranteed at $T_A = +25^\circ\text{C} \pm 5^\circ\text{C}$.
- 6/ Transmission driving tests are performed at $V_{CC} = 5.5 \text{ V}$ with a 2 ms duration maximum. This test may be performed using $V_{IN} = V_{CC}$ or GND. When $V_{IN} = V_{CC}$ or GND is used, the test is guaranteed for $V_{IN} = 2.0 \text{ V}$ or 0.8 V .
- 7/ Three-state output conditions are required.
- 8/ This is the increase in supply current for each input that is at one of the specified TTL voltage levels rather than 0 V or V_{CC} . This test may be performed either one input at a time (preferred method) or with all input pins simultaneously at $V_{IN} = V_{CC} - 2.1 \text{ V}$ (alternate method). Classes Q and V shall use the preferred method. When the test is performed using the alternate test method, the maximum limit is equal to the number of inputs at a high TTL input level times 1.0 mA or 1.60 mA , as applicable; and the preferred method and limits are guaranteed.
- 9/ Power dissipation capacitance (C_{PD}) determines the no load power consumption, $P_D = (C_{PD} + C_L) (V_{CC} \times V_{CC}) f + (I_{CC} \times V_{CC}) + (n \times d \times \Delta I_{CC} \times V_{CC})$. The dynamic current consumption, $I_S = (C_{PD} + C_L) V_{CC} f + I_{CC} + (n \times d \times \Delta I_{CC})$. For both P_D and I_S : n is the number of device inputs at TTL levels; f is the frequency of the input signal; and d is the duty cycle of the input signal.
- 10/ This test is for qualification only. Ground and V_{CC} bounce tests are performed on a non-switching (quiescent) output and are used to measure the magnitude of induced noise caused by other simultaneously switching outputs. The test is performed on a low noise bench test fixture. For the device under test, all outputs shall be loaded with 500Ω of load resistance and a minimum of 50 pF of load capacitance (see figure 4). Only chip capacitors and resistors shall be used. The output load components shall be located as close as possible to the device outputs. It is suggested that, whenever possible, this distance be kept to less than 0.25 inches. Decoupling capacitors shall be placed in parallel from V_{CC} to ground. The values of these decoupling capacitors shall be determined by the device manufacturer. The low and high level ground and V_{CC} bounce noise is measured at the quiet output using a 1 GHz minimum bandwidth oscilloscope with a 50Ω input impedance.

The device inputs shall be conditioned such that all outputs are at a high nominal V_{OH} level. The device inputs shall then be conditioned such that they switch simultaneously and the output under test remains at V_{OH} as all other outputs possible are switched from V_{OH} to V_{OL} . V_{OHV} and V_{OHP} are then measured from the nominal V_{OH} level to the largest negative and positive peaks, respectively (see figure 4). This is then repeated with the same outputs not under test switching from V_{OL} to V_{OH} .

The device inputs shall be conditioned such that all outputs are at a low nominal V_{OL} level. The device inputs shall then be conditioned such that they switch simultaneously and the output under test remains at V_{OL} as all other outputs possible are switched from V_{OL} to V_{OH} . V_{OLP} and V_{OLV} are then measured from the nominal V_{OL} level to the largest positive and negative peaks, respectively (see figure 4). This is then repeated with the same outputs not under test switching from V_{OH} to V_{OL} .
- 11/ See JEDEC STD. 17 for electrically induced latch-up test methods and procedures. The values listed for $V_{trigger}$, $I_{trigger}$ and V_{over} , are to be accurate within ± 5 percent.
- 12/ Tests shall be performed in sequence, attributes data only. Functional tests shall include the truth table and other logic patterns used for fault detection. Functional tests shall be performed in sequence as approved by the qualifying activity on qualified devices. $H \geq 2.5 \text{ V}$, $L < 2.5 \text{ V}$; high inputs = 2.4 V and low inputs = 0.4 V . The input voltage levels have the allowable tolerances per MIL-STD-883 already incorporated.
- 13/ AC limits at $V_{CC} = 5.5 \text{ V}$ are equal to limits at $V_{CC} = 4.5 \text{ V}$ and guaranteed by testing at $V_{CC} = 4.5 \text{ V}$. Minimum AC limits for $V_{CC} = 5.5 \text{ V}$ are 1.0 ns and guaranteed by guardbanding the $V_{CC} = 4.5 \text{ V}$ minimum limits to 1.5 ns . For propagation delay tests, all paths must be tested.

STANDARD MICROCIRCUIT DRAWING DEFENSE SUPPLY CENTER COLUMBUS COLUMBUS, OHIO 43216-5000	SIZE A		5962-92187
		REVISION LEVEL A	SHEET 11

Device type	01
Case outlines	R, S, 2
Terminal number	Terminal symbol
1	— T/R
2	A0
3	A1
4	A2
5	A3
6	A4
7	A5
8	A6
9	A7
10	GND
11	B7
12	B6
13	B5
14	B4
15	B3
16	B2
17	B1
18	<u>B0</u>
19	OE
20	V _{cc}

Pin description	
Terminal symbol	Description
An (n = 0 to 7) Bn (n = 0 to 7)	Input / output banks
— OE	Output enable control
— T/R	Transmit / receive input

FIGURE 1. Terminal connections.

STANDARD MICROCIRCUIT DRAWING DEFENSE SUPPLY CENTER COLUMBUS COLUMBUS, OHIO 43216-5000	SIZE A		5962-92187
		REVISION LEVEL A	SHEET 12

Device type 01		
Inputs		Outputs
\overline{OE}	T/R	
L	L	Bus B data to bus A
L	H	Bus A data to bus B
H	X	High-impedance state

H = High voltage level
L = Low voltage level
X = Immaterial

FIGURE 2. Truth table.

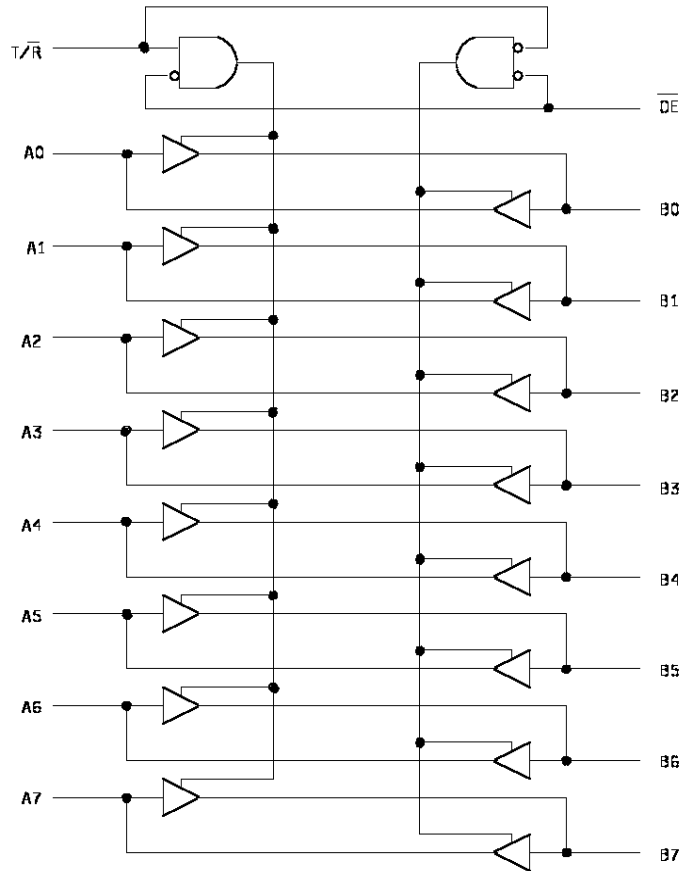
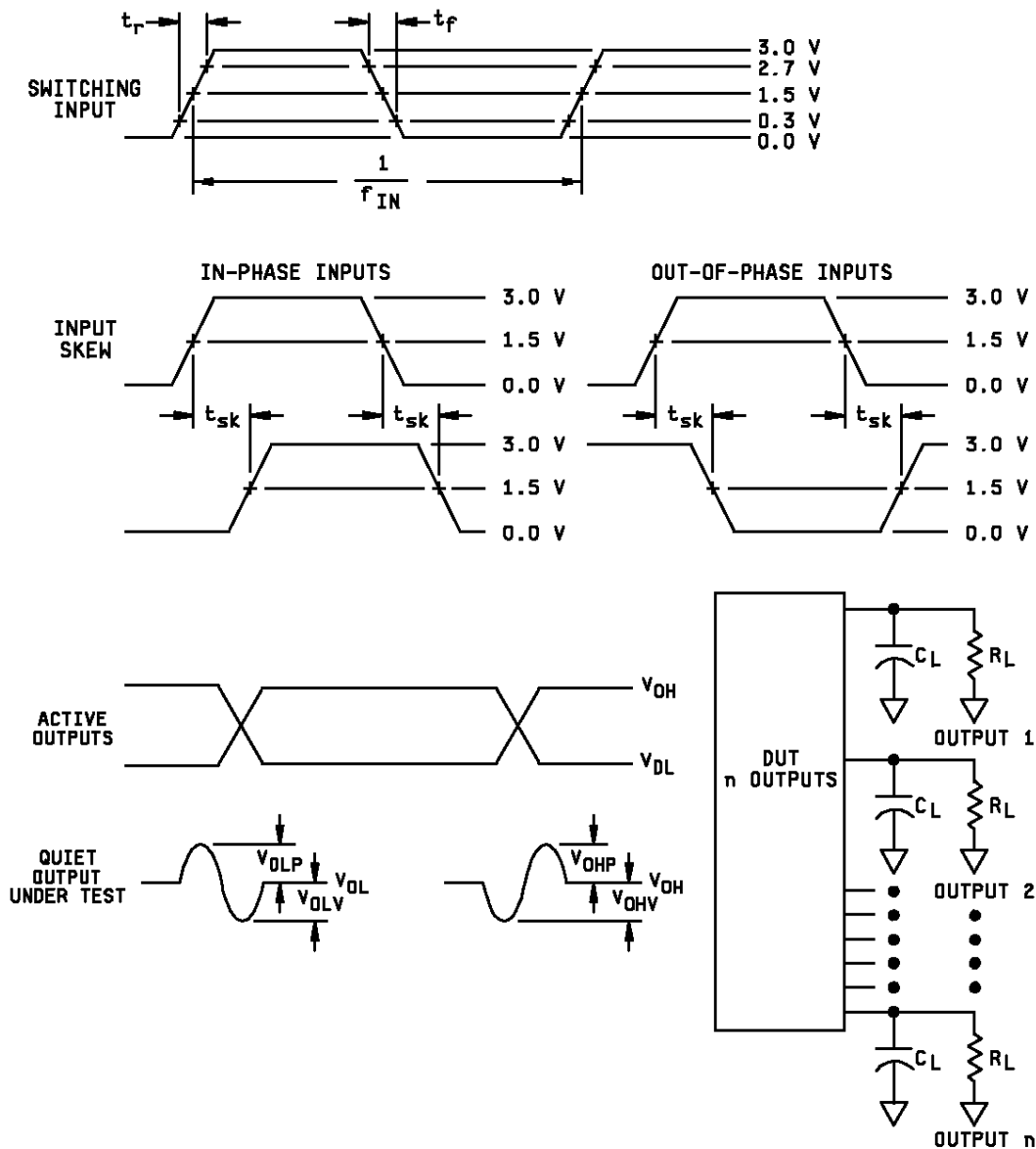

FIGURE 3. Logic diagram.

STANDARD MICROCIRCUIT DRAWING DEFENSE SUPPLY CENTER COLUMBUS COLUMBUS, OHIO 43216-5000	SIZE A		5962-92187
		REVISION LEVEL A	SHEET 13



NOTES:

1. C_L = includes a 47 pF chip capacitor (-0 percent, +20 percent) and at least 3 pF of equivalent capacitance from the test jig and probe.
2. R_L = $450\Omega \pm 1$ percent, chip resistor in series with a 50Ω termination. For monitored outputs, the 50Ω termination shall be the 50Ω characteristic impedance of the coaxial connector to the oscilloscope.
3. Input signal to the device under test:
 - a. $V_{IN} = 0.0$ V to 3.0 V; duty cycle = 50 percent; $f_{IN} \geq 1$ MHz.
 - b. $t_r, t_f = 3$ ns ± 1.0 ns. For input signal generators incapable of maintaining these values of t_r and t_f , the 3.0 ns limit may be increased up to 10 ns, as needed, maintaining the ± 1.0 ns tolerance and guaranteeing the results at 3.0 ns ± 1.0 ns; skew between any two switching input signals (t_{sk}): ≤ 250 ps.

FIGURE 4. Ground bounce load circuit and waveforms.

STANDARD MICROCIRCUIT DRAWING DEFENSE SUPPLY CENTER COLUMBUS COLUMBUS, OHIO 43216-5000	SIZE A		5962-92187
		REVISION LEVEL A	SHEET 14

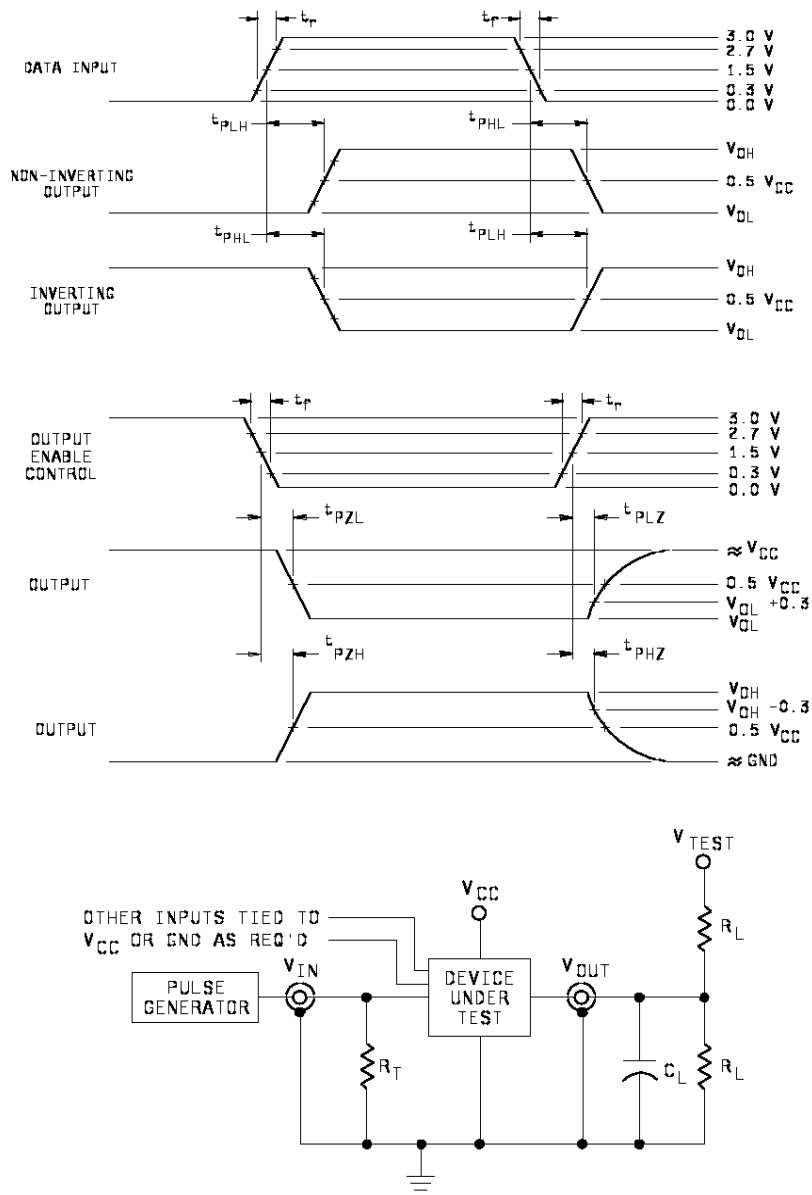

NOTES:

1. When measuring t_{PLZ} and t_{PZL} : $V_{TEST} = 2 \times V_{CC}$.
2. When measuring t_{PHZ} , t_{PZH} , t_{PLH} and t_{PHL} : $V_{TEST} = \text{open}$.
3. The t_{PZL} and t_{PLZ} reference waveform is for the output under test with internal conditions such that the output is at V_{OL} except when disabled by the output enable control. The t_{PZH} and t_{PHZ} reference waveform is for the output under test with internal conditions such that the output is at V_{OH} except when disabled by the output enable control.
4. $C_L = 50 \text{ pF}$ minimum or equivalent (includes test jig and probe capacitance).
5. $R_T = 50\Omega$ or equivalent., $R_L = 500\Omega$ or equivalent.
6. Input signal from pulse generator: $V_{IN} = 0.0 \text{ V}$ to 3.0 V ; $\text{PRR} \leq 10 \text{ MHz}$; $t_r \leq 3.0 \text{ ns}$; $t_f \leq 3.0 \text{ ns}$; t_r and t_f shall be measured from 0.3 V to 2.7 V and from 2.7 V to 0.3 V , respectively; duty cycle = 50 percent.
7. Timing parameters shall be tested at a minimum input frequency of 1 Mhz.
8. The outputs are measured one at a time with one transition per measurement.

FIGURE 5. Switching waveforms and test circuit.

STANDARD MICROCIRCUIT DRAWING DEFENSE SUPPLY CENTER COLUMBUS COLUMBUS, OHIO 43216-5000	SIZE A		5962-92187
		REVISION LEVEL A	SHEET 15

4.3.1 Electrostatic discharge sensitivity qualification inspection. Electrostatic discharge sensitivity (ESDS) testing shall be performed in accordance with MIL-STD-883, method 3015. ESDS testing shall be measured only for initial qualification and after process or design changes which may affect ESDS classification.

4.4 Conformance inspection. Technology conformance inspection for classes Q and V shall be in accordance with MIL-PRF-38535 including groups A, B, C, D, and E inspections and as specified herein except where option 2 of MIL-PRF-38535 permits alternate in-line control testing. Quality conformance inspection for device class M shall be in accordance with MIL-PRF-38535, appendix A and as specified herein. Inspections to be performed for device class M shall be those specified in method 5005 of MIL-STD-883 and herein for groups A, B, C, D, and E inspections (see 4.4.1 through 4.4.4).

TABLE II. Electrical test requirements.

Test requirements	Subgroups (in accordance with MIL-STD-883, method 5005, table I)	Subgroups (in accordance with MIL-PRF-38535, table III)	
	Device class M	Device class Q	Device class V
Interim electrical parameters (see 4.2)	- - -	1	1
Final electrical parameters (see 4.2)	<u>1/</u> 1, 2, 3, 7, 8, 9	<u>1/</u> 1, 2, 3, 7, 8, 9, 10, 11	<u>2/</u> 1, 2, 3, 7, 8, 9, 10, 11
Group A test requirements (see 4.4)	1, 2, 3, 4, 7, 8, 9, 10, 11	1, 2, 3, 4, 7, 8, 9, 10, 11	1, 2, 3, 4, 7, 8, 9, 10, 11
Group C end-point electrical parameters (see 4.4)	1, 2, 3	1, 2, 3	1, 2, 3, 7, 8, 9, 10, 11
Group D end-point electrical parameters (see 4.4)	1, 2, 3	1, 2, 3	1, 2, 3
Group E end-point electrical parameters (see 4.4)	1, 7, 9	1, 7, 9	1, 7, 9

1/ PDA applies to subgroup 1.

2/ PDA applies to subgroups 1 and 7.

4.4.1 Group A inspection.

- a. Tests shall be as specified in Table II herein.
- b. Latch-up tests are required for device classes Q and V. These tests shall be performed only for initial qualification and after process or design changes which may affect the performance of the device. Latch-up tests shall be considered destructive. Test all applicable pins on five devices with zero failures.
- c. Ground and V_{CC} bounce tests are required for all device classes. These tests shall be performed only for initial qualification and after process or design changes which may affect the performance of the device. V_{OLP}, V_{OLV}, V_{OHP}, and V_{OHV} shall be measured for the worst case outputs of the device. All other outputs shall be guaranteed, if not tested, to limits established for the worst case outputs. The worst case outputs tested are to be determined by the manufacturer. Test 5 devices assembled in the worst case package type supplied to this document. All other package types shall be guaranteed, if not tested, to limits established for the worst case package. The package type to be tested shall be determined by the manufacturer. The device manufacturer will submit to DSCC data that shall include all measured peak values for each device tested and detailed oscilloscope plots for each V_{OLP}, V_{OLV}, V_{OHP}, and V_{OHV} from one sample part per function. The plot shall contain the waveforms of both a switching output and the output under test.

STANDARD MICROCIRCUIT DRAWING DEFENSE SUPPLY CENTER COLUMBUS COLUMBUS, OHIO 43216-5000	SIZE A		5962-92187
		REVISION LEVEL A	SHEET 16

Device manufacturers may test product on the fixtures they currently use and guarantee the product they supply to this drawing will meet the test conditions and limits specified in this drawing. This can be accomplished if the tests results on their fixtures, after testing as described in this drawing, are such that the magnitude of the measured peaks shall be within +100 mV of the limits specified for the standard fixture, herein. There is no constraint on the attenuation of these peaks. The manufacturers may show correlation between their fixture and the standard fixture by testing the same devices to the requirements herein, at a minimum, the 244, 374, and 573 function devices on both fixtures. The manufacturer will then guarantee the test results for the remaining functions in this technology family to the standard fixture.

- d. C_{IN} , C_{OUT} , and C_{PD} shall be measured only for initial qualification and after process or design changes which may affect capacitance. C_{IN} and C_{OUT} shall be measured between the designated terminal and GND at a frequency of 1 MHz. C_{PD} shall be tested in accordance with the latest revision of JEDEC Standard No. 20 and table I herein. For C_{IN} , C_{OUT} , and C_{PD} , test all applicable pins on five devices with zero failures.
- e. For device class M, subgroups 7 and 8 tests shall be sufficient to verify the truth table in figure 2 herein. The test vectors used to verify the truth table shall test all possible input to output logic patterns of each function of the device. For device classes Q and V, subgroups 7 and 8 shall include verifying the functionality of the device; these tests shall have been fault graded in accordance with MIL-STD-883, test method 5012 (see 1.5 herein).

4.4.2 Group C inspection. The group C inspection end-point electrical parameters shall be as specified in table II herein.

4.4.2.1 Additional criteria for device class M. Steady-state life test conditions, method 1005 of MIL-STD-883:

- a. Test condition A, B, C, or D. The test circuit shall be maintained by the manufacturer under document revision level control and shall be made available to the preparing or acquiring activity upon request. The test circuit shall specify the inputs, outputs, biases, and power dissipation, as applicable, in accordance with the intent specified in test method 1005 of MIL-STD-883.
- b. $T_A = +125^\circ\text{C}$, minimum.
- c. Test duration: 1,000 hours, except as permitted by method 1005 of MIL-STD-883.

4.4.2.2 Additional criteria for device classes Q and V. The steady-state life test duration, test condition and test temperature, or approved alternatives shall be as specified in the device manufacturer's QM plan in accordance with MIL-PRF-38535. The test circuit shall be maintained under document revision level control by the device manufacturer's TRB in accordance with MIL-PRF-38535 and shall be made available to the acquiring or preparing activity upon request. The test circuit shall specify the inputs, outputs, biases, and power dissipation, as applicable, in accordance with the intent specified in test method 1005 of MIL-STD-883.

4.4.3 Group D inspection. The group D inspection end-point electrical parameters shall be as specified in table II herein.

4.4.4 Group E inspection. Group E inspection is required only for parts intended to be marked as radiation hardness assured (see 3.5 herein).

- a. End-point electrical parameters shall be as specified in table II herein.
- b. For device classes Q and V, the devices or test vehicle shall be subjected to radiation hardness assured tests as specified in MIL-PRF-38535 for the RHA level being tested. For device class M, the devices shall be subjected to radiation hardness assured tests as specified in MIL-PRF-38535, appendix A for the RHA level being tested.
- c. When specified in the purchase order or contract, a copy of the RHA delta limits shall be supplied.
- d. RHA tests for device class M for levels M, D, L, R, F, G, and H shall be performed through each level to determine at what levels the devices meet the RHA requirements. These RHA tests shall be performed for initial qualification and after design or process changes which may affect the RHA performance of the device.
- e. Prior to irradiation, each selected sample shall be assembled in its qualified package. It shall pass the specified group A electrical parameters in table I for subgroups specified in table II herein.

STANDARD MICROCIRCUIT DRAWING DEFENSE SUPPLY CENTER COLUMBUS COLUMBUS, OHIO 43216-5000	SIZE A		5962-92187
		REVISION LEVEL A	SHEET 17

- f. For device classes Q, and V, the devices or test vehicle shall be subjected to radiation hardness assured tests as specified in MIL-PRF-38535 for the RHA level being tested. For device class M, the devices shall be subjected to radiation hardness assured tests as specified in MIL-PRF-38535, appendix A for the RHA level being tested. All device classes must meet the postirradiation end-point electrical parameter limits as defined in table I at $T_A = +25^{\circ}\text{C} \pm 5^{\circ}\text{C}$, after exposure, to the subgroups specified in table II herein.

4.4.4.1 Total dose irradiation testing. Total dose irradiation testing shall be performed in accordance with MIL-STD-883, method 1019, and as specified herein:

Prior to and during total dose irradiation characterization and testing, the devices for characterization shall be biased so that 50 percent are at inputs high and 50 percent are at inputs low, and the devices for testing shall be biased to the worst case condition established during characterization. Devices shall be biased as follows:

1. Inputs tested high, $V_{CC} = 5.5 \text{ V dc } +5\%$, $R_{CC} = 10\Omega \pm 20\%$, $V_{IN} = 5.0 \text{ V dc } +5\%$, $R_{IN} = 1 \text{ k}\Omega \pm 20\%$, and all outputs are open.
2. Inputs tested low, $V_{CC} = 5.5 \text{ V dc } +5\%$, $R_{CC} = 10\Omega \pm 20\%$, $V_{IN} = 0.0 \text{ V dc}$, $R_{IN} = 1 \text{ k}\Omega \pm 20\%$, and all outputs are open.

4.4.4.1.1 Accelerated aging test. Accelerated aging shall be performed on class M, Q, and V devices requiring an RHA level greater than 5K rads (Si). The post-anneal end point electrical parameter limits shall be as specified in table I herein and shall be the preirradiation end point electrical parameter limit at $25^{\circ}\text{C} \pm 5^{\circ}\text{C}$. Testing shall be performed at initial qualification and after any design or process changes which may effect the RHA response of the device.

4.5 Methods of inspection. Methods of inspection shall be specified as follows:

4.5.1 Voltage and current. Unless otherwise specified, all voltages given are referenced to the microcircuit GND terminal. Currents given are conventional current and positive when flowing into the referenced terminal.

5. PACKAGING

5.1 Packaging requirements. The requirements for packaging shall be in accordance with MIL-PRF-38535 for device classes Q and V or MIL-PRF-38535, appendix A for device class M.

6. NOTES

6.1 Intended use. Microcircuits conforming to this drawing are intended for use for Government microcircuit applications (original equipment), design applications, and logistics purposes.

6.1.1 Replaceability. Microcircuits covered by this drawing will replace the same generic device covered by a contractor-prepared specification or drawing.

6.1.2 Substitutability. Device class Q devices will replace device class M devices.

6.2 Configuration control of SMD's. All proposed changes to existing SMD's will be coordinated with the users of record for the individual documents. This coordination will be accomplished in accordance with MIL-STD-973 using DD Form 1692, Engineering Change Proposal.

6.3 Record of users. Military and industrial users should inform Defense Supply Center Columbus when a system application requires configuration control and which SMD's are applicable to that system. DSCC will maintain a record of users and this list will be used for coordination and distribution of changes to the drawings. Users of drawings covering microelectronic devices (FSC 5962) should contact DSCC-VA, telephone (614) 692-0525.

6.4 Comments. Comments on this drawing should be directed to DSCC-VA, Columbus, Ohio 43216-5000, or telephone (614) 692-0674.

6.5 Abbreviations, symbols, and definitions. The abbreviations, symbols, and definitions used herein are defined in MIL-PRF-38535 and MIL-HDBK-1331.

STANDARD MICROCIRCUIT DRAWING DEFENSE SUPPLY CENTER COLUMBUS COLUMBUS, OHIO 43216-5000	SIZE A		5962-92187
		REVISION LEVEL A	SHEET 18

6.6 Sources of supply.

6.6.1 Sources of supply for device classes Q and V. Sources of supply for device classes Q and V are listed in QML-38535. The vendors listed in QML-38535 have submitted a certificate of compliance (see 3.6 herein) to DSCC-VA and have agreed to this drawing.

6.6.2 Approved sources of supply for device class M. Approved sources of supply for class M are listed in MIL-HDBK-103. The vendors listed in MIL-HDBK-103 have agreed to this drawing and a certificate of compliance (see 3.6 herein) has been submitted to and accepted by DSCC-VA.

STANDARD MICROCIRCUIT DRAWING DEFENSE SUPPLY CENTER COLUMBUS COLUMBUS, OHIO 43216-5000	SIZE A		5962-92187
		REVISION LEVEL A	SHEET 19

STANDARD MICROCIRCUIT DRAWING SOURCE APPROVAL BULLETIN

DATE: 98-05-29

Approved sources of supply for SMD 5962-92187 are listed below for immediate acquisition information only and shall be added to MIL-HDBK-103 and QML-38535 during the next revision. MIL-HDBK-103 and QML-38535 will be revised to include the addition or deletion of sources. The vendors listed below have agreed to this drawing and a certificate of compliance has been submitted to and accepted by DSCC-VA. This bulletin is superseded by the next dated revision of MIL-HDBK-103 and QML-38535.

Standard microcircuit drawing PIN <u>1/</u>	Vendor CAGE number	Vendor similar PIN <u>2/</u>
5962-9218701MRA	27014	54ACTQ245DMQB
5962-9218701MSA	27014	54ACTQ245FMQB
5962-9218701M2A	27014	54ACTQ245LMQB
5962R9218701MRA	27014	54ACTQ245DMQB-R
5962R9218701MSA	27014	54ACTQ245FMQB-R
5962R9218701M2A	27014	54ACTQ245LMQB-R
5962R9218701VRA	27014	54ACTQ245JRQMLV
5962R9218701VSA	27014	54ACTQ245WRQMLV
5962R9218701V2A	27014	54ACTQ245ERQMLV

1/ The lead finish shown for each PIN representing a hermetic package is the most readily available from the manufacturer listed for that part. If the desired lead finish is not listed contact the Vendor to determine its availability.

2/ Caution. Do not use this number for item acquisition. Items acquired to this number may not satisfy the performance requirements of this drawing.

Vendor CAGE
number

27014

Vendor name
and address

National Semiconductor
2900 Semiconductor Drive
P. O. Box 58090
Santa Clara, CA 95052-8090
Point of contact: 5 Foden Road
South Portland, ME 04106

The information contained herein is disseminated for convenience only and the Government assumes no liability whatsoever for any inaccuracies in the information bulletin.