

REVISIONS

LTR	DESCRIPTION	DATE (YR-MO-DA)	APPROVED
A	Radiation requirements added to drawing. Update to reflect latest changes in format and requirements. Corrections made to Y case outline dimensions. Editorial changes throughout. --les	04-03-15	Raymond Monnin

REV																			
SHEET																			
REV	A																		
SHEET	15																		
REV STATUS	REV	A	A	A	A	A	A	A	A	A	A	A	A	A	A	A	A	A	A
OF SHEETS	SHEET	1	2	3	4	5	6	7	8	9	10	11	12	13	14				
PMIC N/A	PREPARED BY	<p align="center">DEFENSE SUPPLY CENTER COLUMBUS COLUMBUS, OHIO 43216 http://www.dsccl.dla.mil</p>																	
<p align="center">STANDARD MICROCIRCUIT DRAWING</p> <p align="center">THIS DRAWING IS AVAILABLE FOR USE BY ALL DEPARTMENTS AND AGENCIES OF THE DEPARTMENT OF DEFENSE</p> <p align="center">AMSC N/A</p>	CHECKED BY	<p>Thomas M. Hess</p>																	
	APPROVED BY	<p>Monica L. Poelking</p>																	
	DRAWING APPROVAL DATE	<p align="center">94-04-28</p>																	
	REVISION LEVEL	SIZE	CAGE CODE																
A	A	67268	5962-94591																
	SHEET	1	OF	15															

1. SCOPE

1.1 Scope. This drawing documents two product assurance class levels consisting of high reliability (device classes Q and M) and space application (device class V). A choice of case outlines and lead finishes are available and are reflected in the Part or Identifying Number (PIN). When available, a choice of Radiation Hardness Assurance (RHA) levels are reflected in the PIN.

1.2 PIN. The PIN shall be as shown in the following example:

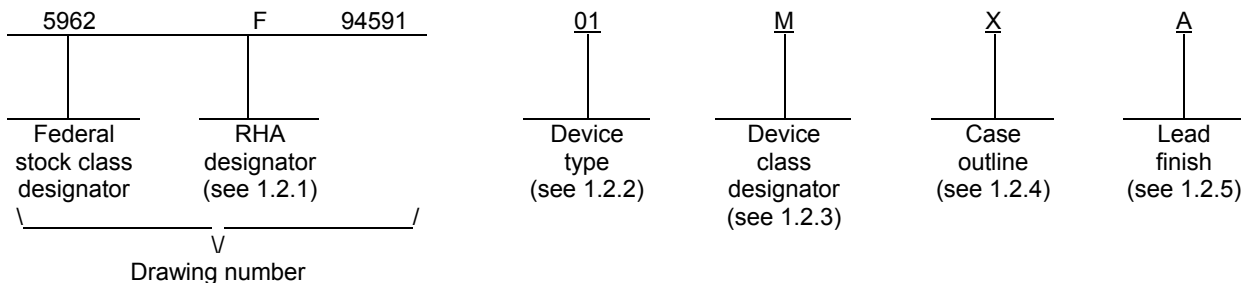

1.2.1 RHA designator. Device classes Q and V RHA marked devices meet the MIL-PRF-38535 specified RHA levels and are marked with the appropriate RHA designator. Device class M RHA marked devices meet the MIL-PRF-38535, appendix A specified RHA levels and are marked with the appropriate RHA designator. A dash (-) indicates a non-RHA device.

1.2.2 Device type. The device type identifies the circuit function as follows:

<u>Device type</u>	<u>Generic number</u>	<u>Circuit function</u>
01	100341	Low power, 8-bit shift register

1.2.3 Device class designator. The device class designator is a single letter identifying the product assurance level as listed below.

<u>Device class</u>	<u>Device requirements documentation</u>
M	Vendor self-certification to the requirements for MIL-STD-883 compliant, non-JAN class level B microcircuits in accordance with MIL-PRF-38535, appendix A
Q or V	Certification and qualification to MIL-PRF-38535

1.2.4 Case outlines. The case outlines are as designated in MIL-STD-1835 and as follows:

<u>Outline letter</u>	<u>Descriptive designator</u>	<u>Terminals</u>	<u>Package style</u>
X	GDIP5-T24 or CDIP6-T24	24	dual-in-line
Y	See figure 1	24	quad-flat

1.2.5 Lead finish. The lead finish is as specified in MIL-PRF-38535 for device classes Q and V or MIL-PRF-38535, appendix A for device class M.

STANDARD MICROCIRCUIT DRAWING DEFENSE SUPPLY CENTER COLUMBUS COLUMBUS, OHIO 43216-5000	SIZE A		5962-94591
		REVISION LEVEL A	SHEET 2

1.3 Absolute maximum ratings. 1/

Supply voltage range (V_{EE})	-7.0 V dc to +0.5 V dc
Dc input voltage range (V_{IN})	V_{EE} to +0.5 V dc
Dc input current range (I_{IN})	-30 mA to +5.0 mA
Storage temperature range.....	-65°C to +150°C
Maximum dc output current (I_{OUT})	-50 mA
Maximum power dissipation (P_D)	750 mW
Lead temperature (soldering, 10 seconds)	+300°C
Junction temperature (T_J)	+175°C
Thermal resistance, junction-to-case (θ_{JC}):	See MIL-STD-1835

1.4 Recommended operating conditions.

Negative supply voltage range (V_{EE})	-5.7 V dc minimum to -4.2 V dc maximum
High level input voltage range (V_{IH})	-1.165 V dc minimum to -0.870 V dc maximum
Low level output voltage (V_{OL})	-1.830 V dc minimum to -1.475 V dc maximum
Ambient operating temperature range (T_C)	-55°C to +125°C

1.5 Radiation features.

Maximum total dose available (dose rate = 50 – 300 rads(Si)/s)..... 300 Krads (Si)

2. APPLICABLE DOCUMENTS

2.1 Government specification, standards, and handbooks. The following specification, standards, and handbooks form a part of this drawing to the extent specified herein. Unless otherwise specified, the issues of these documents are those listed in the issue of the Department of Defense Index of Specifications and Standards (DoDISS) and supplement thereto, cited in the solicitation.

SPECIFICATION

DEPARTMENT OF DEFENSE

MIL-PRF-38535 -- Integrated Circuits, Manufacturing, General Specification for.

STANDARDS

DEPARTMENT OF DEFENSE

MIL-STD-883 - Test Method Standard Microcircuits.
 MIL-STD-1835 - Interface Standard Electronic Component Case Outlines.

1/ Stresses above the absolute maximum rating may cause permanent damage to the device. Extended operation at the maximum levels may degrade performance and affect reliability.

STANDARD MICROCIRCUIT DRAWING DEFENSE SUPPLY CENTER COLUMBUS COLUMBUS, OHIO 43216-5000	SIZE A		5962-94591
		REVISION LEVEL A	SHEET 3

HANDBOOKS

DEPARTMENT OF DEFENSE

- MIL-HDBK-103 - List of Standard Microcircuit Drawings.
- MIL-HDBK-780 - Standard Microcircuit Drawings.

(Unless otherwise indicated, copies of the specification, standards, and handbooks are available from the Standardization Document Order Desk, 700 Robbins Avenue, Building 4D, Philadelphia, PA 19111-5094.)

2.2 Order of precedence. In the event of a conflict between the text of this drawing and the references cited herein, the text of this drawing takes precedence. Nothing in this document, however, supersedes applicable laws and regulations unless a specific exemption has been obtained.

3. REQUIREMENTS

3.1 Item requirements. The individual item requirements for device classes Q and V shall be in accordance with MIL-PRF-38535 and as specified herein or as modified in the device manufacturer's Quality Management (QM) plan. The modification in the QM plan shall not affect the form, fit, or function as described herein. The individual item requirements for device class M shall be in accordance with MIL-PRF-38535, appendix A for non-JAN class level B devices and as specified herein.

3.2 Design, construction, and physical dimensions. The design, construction, and physical dimensions shall be as specified in MIL-PRF-38535 and herein for device classes Q and V or MIL-PRF-38535, appendix A and herein for device class M.

3.2.1 Case outlines. The case outlines shall be in accordance with 1.2.4 herein and figure 1.

3.2.2 Terminal connections. The terminal connections shall be as specified on figure 2.

3.2.3 Truth table. The truth table shall be as specified on figure 3.

3.2.4 Logic diagram. The logic diagram shall be as specified on figure 4.

3.2.5 Test circuit and switching waveforms. The test circuit and switching waveforms shall be as specified on figure 5.

3.2.6 Radiation exposure circuit. The radiation exposure circuit shall be maintained by the manufacturer under document revision level control and shall be made available to the preparing and acquiring activity upon request.

3.3 Electrical performance characteristics and post-irradiation parameter limits. Unless otherwise specified herein, the electrical performance characteristics and post-irradiation parameter limits are as specified in table I and shall apply over the full case operating temperature range.

3.4 Electrical test requirements. The electrical test requirements shall be the subgroups specified in table II. The electrical tests for each subgroup are defined in table I.

3.5 Marking. The part shall be marked with the PIN listed in 1.2 herein. In addition, the manufacturer's PIN may also be marked as listed in MIL-HDBK-103. For packages where marking of the entire SMD PIN number is not feasible due to space limitations, the manufacturer has the option of not marking the "5962-" on the device. For RHA product using this option, the RHA designator shall still be marked. Marking for device classes Q and V shall be in accordance with MIL-PRF-38535. Marking for device class M shall be in accordance with MIL-PRF-38535, appendix A.

3.5.1 Certification/compliance mark. The certification mark for device classes Q and V shall be a "QML" or "Q" as required in MIL-PRF-38535. The compliance mark for device class M shall be a "C" as required in MIL-PRF-38535, appendix A.

STANDARD MICROCIRCUIT DRAWING DEFENSE SUPPLY CENTER COLUMBUS COLUMBUS, OHIO 43216-5000	SIZE A		5962-94591
		REVISION LEVEL A	SHEET 4

TABLE I. Electrical performance characteristics.

Test	Symbol	Conditions -55°C ≤ T _C ≤ +125°C <u>1/</u> <u>3/</u> unless otherwise specified	Group A subgroups	Device type	Limits		Unit
					Min	Max	
High level output voltage	V _{OH}	V _{EE} = -4.2 V, -5.7 V, V _{IH} = -0.87 V,	1, 2 3	All	-1.025 -1.085	-0.870 -0.870	V
Low level output voltage	V _{OL}	V _{IL} = -1.83 V, Loading 50Ω to -2.0 V	1, 2 3	All	-1.830 -1.830	-1.620 -1.555	V
High level threshold output voltage	V _{OHC}	V _{EE} = -4.2 V, -5.7 V, V _{IH} = -1.165 V,	1, 2 3	All	-1.035 -1.085		V
Low level threshold output voltage	V _{OLC}	V _{IL} = -1.475 V, Loading 50Ω to -2.0 V	1, 2 3	All		-1.610 -1.555	V
Negative power supply drain current	I _{EE}	V _{EE} = -4.2 V, -5.7 V, V _{EE} = -4.2 V, -4.8 V,	1, 2, 3 1, 2, 3	All	-178 -168	-55 -55	mA mA
Low level input current	I _{IL}	V _{EE} = -4.2 V, V _{IN} = -1.83 V	1, 2, 3	All	0.5		μA
High level input current	I _{IH}	V _{EE} = -5.7 V, V _{IN} = -0.87 V	1, 2 3	All		240 340	μA
Functional tests		V _{EE} = -4.2 V, -5.7 V, V _{IN} = -1.165 V, V _{IL} = -1.830 V, See 4.4.1c.	7, 8	All			
Propagation delay time CP to output	t _{PLH1} t _{PLH1}	V _{EE} = -4.2 V to -5.7 V See figure 5	9 10 11	All	0.5 0.5 0.5	2.3 2.8 2.5	ns
Transition time, Q _n <u>2/</u>	t _{TLH} t _{THL}		9, 10, 11	All	0.3	1.3	ns
Setup time <u>2/</u>	t _s		D _n to CP P _n to CP S _n to CP 9 10 11		0.6 0.6 1.6 2.4 1.7		ns
Hold time <u>2/</u>	t _h		D _n to CP P _n to CP S _n to CP 9 10 11		0.9 0.9 0.5		ns
Pulse width <u>2/</u>	T _{DW(H)}		9, 10, 11		2.0		ns
Max clock frequency <u>2/</u>	f _{MAX}		9 10 11		400 300 400		MHz

1/ Pre and Post-irradiation values are identical unless otherwise specified in table I. When performing post-irradiation electrical measurements for any RHA level, T_A = +25°C.

2/ This parameter is provided as design information only (not tested but guaranteed).

3/ This product is irradiated and post-irradiation tested at M, D, P, L, R, and F levels and meets the Table I limits.

STANDARD MICROCIRCUIT DRAWING DEFENSE SUPPLY CENTER COLUMBUS COLUMBUS, OHIO 43216-5000	SIZE A		5962-94591
		REVISION LEVEL A	SHEET 5

3.6 Certificate of compliance. For device classes Q and V, a certificate of compliance shall be required from a QML-38535 listed manufacturer in order to supply to the requirements of this drawing (see 6.6.1 herein). For device class M, a certificate of compliance shall be required from a manufacturer in order to be listed as an approved source of supply in MIL-HDBK-103 (see 6.6.2 herein). The certificate of compliance submitted to DSCC-VA prior to listing as an approved source of supply for this drawing shall affirm that the manufacturer's product meets, for device classes Q and V, the requirements of MIL-PRF-38535 and herein or for device class M, the requirements of MIL-PRF-38535, appendix A and herein.

3.7 Certificate of conformance. A certificate of conformance as required for device classes Q and V in MIL-PRF-38535 or for device class M in MIL-PRF-38535, appendix A shall be provided with each lot of microcircuits delivered to this drawing.

3.8 Notification of change for device class M. For device class M, notification to DSCC-VA of change of product (see 6.2 herein) involving devices acquired to this drawing is required for any change as defined in MIL-PRF-38535, appendix A.

3.9 Verification and review for device class M. For device class M, DSCC, DSCC's agent, and the acquiring activity retain the option to review the manufacturer's facility and applicable required documentation. Offshore documentation shall be made available onshore at the option of the reviewer.

3.10 Microcircuit group assignment for device class M. Device class M devices covered by this drawing shall be in microcircuit group number 33 (see MIL-PRF-38535, appendix A).

4. QUALITY ASSURANCE PROVISIONS

4.1 Sampling and inspection. For device classes Q and V, sampling and inspection procedures shall be in accordance with MIL-PRF-38535 or as modified in the device manufacturer's Quality Management (QM) plan. The modification in the QM plan shall not affect the form, fit, or function as described herein. For device class M, sampling and inspection procedures shall be in accordance with MIL-PRF-38535, appendix A.

STANDARD MICROCIRCUIT DRAWING DEFENSE SUPPLY CENTER COLUMBUS COLUMBUS, OHIO 43216-5000	SIZE A		5962-94591
		REVISION LEVEL A	SHEET 6

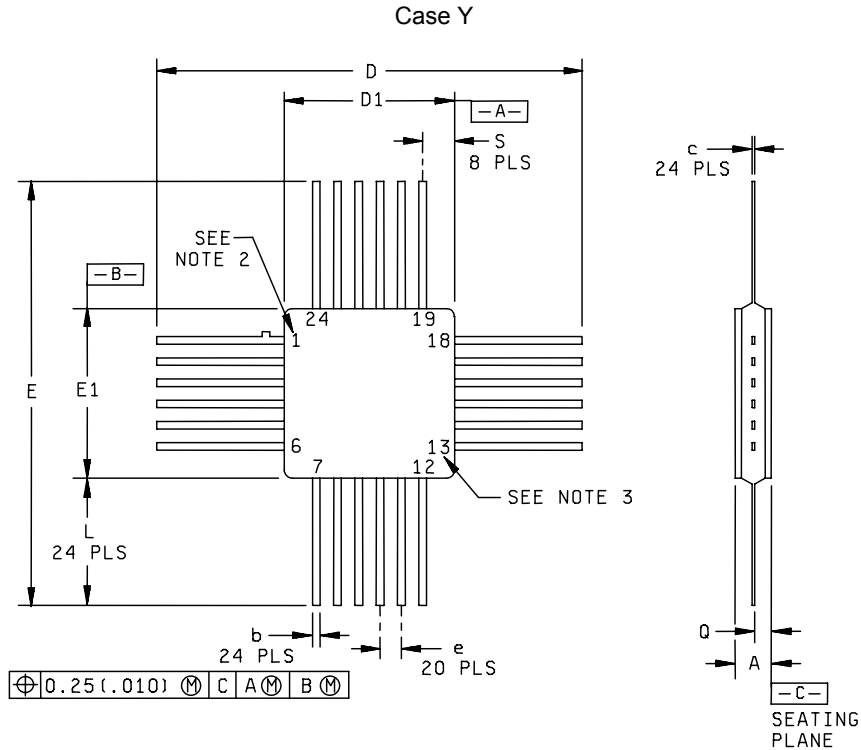

Dimension	Millimeters		Inches		Notes
	Min	Max	Min	Max	
A		2.16		.085	
b	0.41	0.46	.015	.019	
c	0.10	0.15	.004	.007	
D	22.10	28.45	.870	1.120	
D1	9.40	10.16	.370	.400	4
E	22.10	28.45	.870	1.120	
E1	9.40	10.16	.370	.400	4
e	1.14	1.40	.045	.055	
L	6.35	9.14	.250	.360	
Q	0.89	1.27	.035	.050	5
S		1.91		.075	

NOTES:

1. The preferred unit of measurement is millimeters. However, this item was designed using inch-pound units of measurement. In case problems involving conflicts between the metric and inch-pound units, the inch-pound units shall rule.
2. Lead number 1 is identified by a tab located on the lead.
3. Lead numbers are shown for reference only and do not appear on the package.
4. Dimensions D1 and E1 allow glass meniscus.
5. Dimension Q shall be measured at the point of exit of the lead from the body.

FIGURE 1. Case outline.

STANDARD MICROCIRCUIT DRAWING DEFENSE SUPPLY CENTER COLUMBUS COLUMBUS, OHIO 43216-5000	SIZE A		5962-94591
		REVISION LEVEL A	SHEET 7

Device type	01	01
Case outlines	X	Y
Terminal number	Terminal symbol	Terminal symbol
1	D ₀	P ₂
2	Q ₀	P ₁
3	Q ₁	P ₀
4	Q ₂	D ₀
5	Q ₃	Q ₀
6	V _{CC}	Q ₁
7	V _{CCA}	Q ₂
8	Q ₄	Q ₃
9	Q ₅	V _{CC}
10	Q ₆	V _{CCA}
11	Q ₇	Q ₄
12	D ₇	Q ₅
13	P ₇	Q ₆
14	P ₆	Q ₇
15	P ₅	D ₇
16	P ₄	P ₇
17	CP	P ₆
18	V _{EE}	P ₅
19	S ₀	P ₄
20	S ₁	CP
21	P ₃	V _{EE}
22	P ₂	S ₀
23	P ₁	S ₁
24	P ₀	P ₃

FIGURE 2. Terminal connections.

STANDARD MICROCIRCUIT DRAWING DEFENSE SUPPLY CENTER COLUMBUS COLUMBUS, OHIO 43216-5000	SIZE A		5962-94591
		REVISION LEVEL A	SHEET 8

Function	Inputs					Outputs							
	D ₇	D ₀	S ₁	S ₀	CP	Q ₇	Q ₆	Q ₅	Q ₄	Q ₃	Q ₂	Q ₁	Q ₀
Load register	X	X	L	L	L to H	P ₇	P ₆	P ₅	P ₄	P ₃	P ₂	P ₁	P ₀
Shift left	X	L	L	H	L to H	Q ₆	Q ₅	Q ₄	Q ₃	Q ₂	Q ₁	Q ₀	L
Shift left	X	H	L	H	L to H	Q ₆	Q ₅	Q ₄	Q ₃	Q ₂	Q ₁	Q ₀	H
Shift right	L	X	H	L	L to H	L	Q ₇	Q ₆	Q ₅	Q ₄	Q ₃	Q ₂	Q ₁
Shift right	H	X	H	L	L to H	H	Q ₇	Q ₆	Q ₅	Q ₄	Q ₃	Q ₂	Q ₁
Hold	X	X	H	H	X	No change							
Hold	X	X	X	X	H								
Hold	X	X	X	X	L								

H = High voltage level
L = Low voltage level.
X = Irrelevant.
L to H = Low to High transition.

FIGURE 3. Truth table.

STANDARD MICROCIRCUIT DRAWING DEFENSE SUPPLY CENTER COLUMBUS COLUMBUS, OHIO 43216-5000	SIZE A		5962-94591
		REVISION LEVEL A	SHEET 9

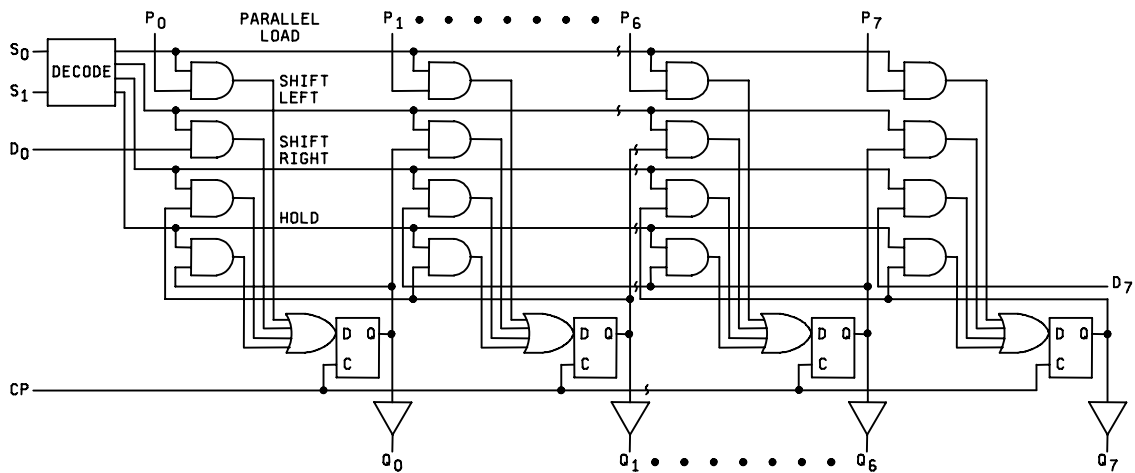

FIGURE 4. Logic diagram.

STANDARD MICROCIRCUIT DRAWING DEFENSE SUPPLY CENTER COLUMBUS COLUMBUS, OHIO 43216-5000	SIZE A		5962-94591
		REVISION LEVEL A	SHEET 10

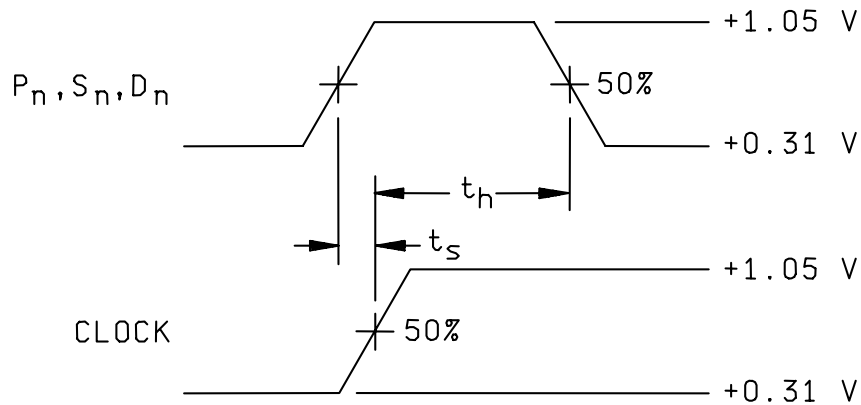
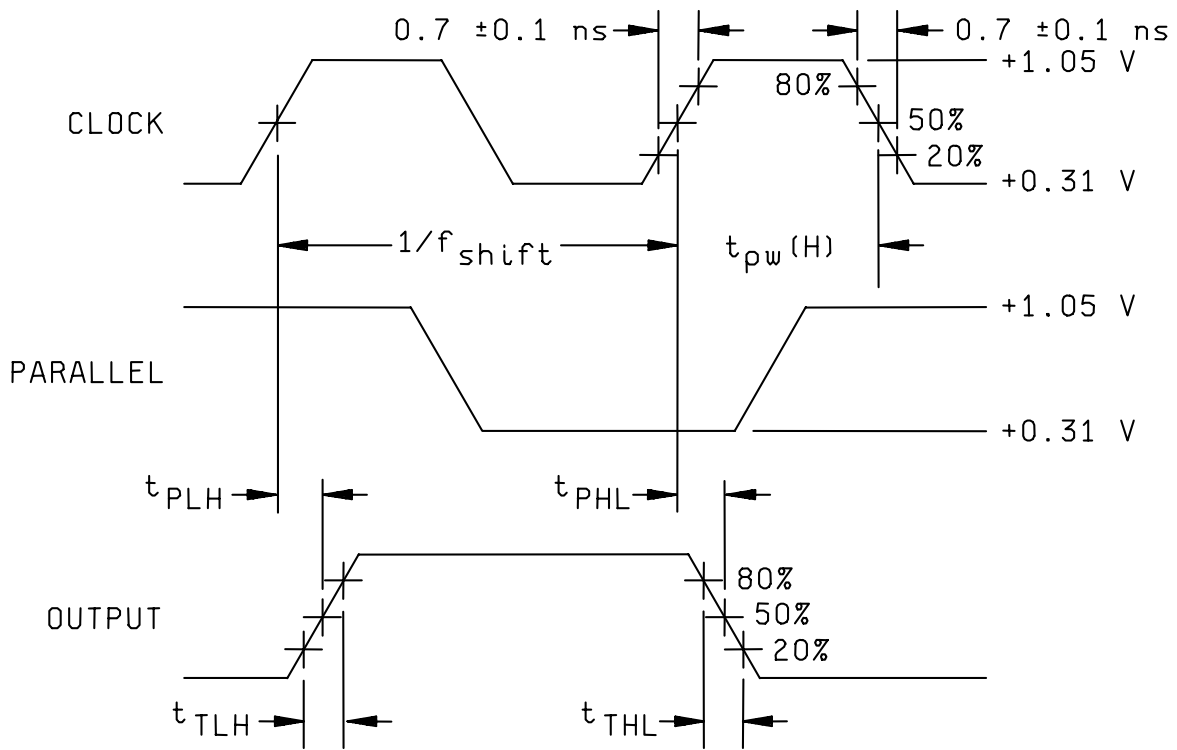
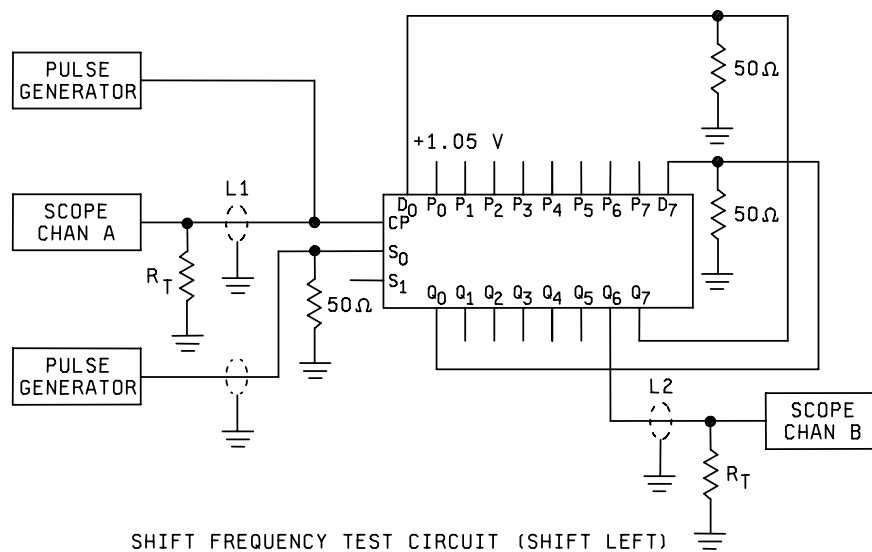
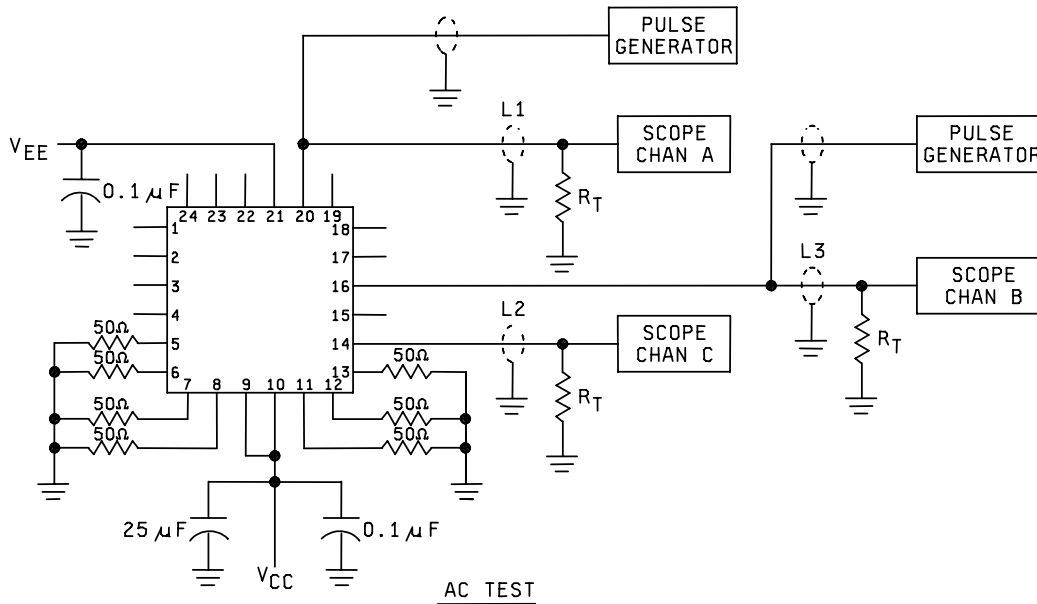

FIGURE 5. Test circuit and switching waveforms.

STANDARD MICROCIRCUIT DRAWING DEFENSE SUPPLY CENTER COLUMBUS COLUMBUS, OHIO 43216-5000	SIZE A		5962-94591
		REVISION LEVEL A	SHEET 11



NOTES:

1. $V_{CC} = V_{CCA} = +2.0 \text{ V}$, $V_{EE} = -2.5 \text{ V}$.
2. L1, L2 and L3 equal length 50Ω impedance lines.
3. $R_T = 50\Omega$ terminator internal to scope.
4. Decoupling $0.1 \mu\text{F}$ from GND to V_{CC} and V_{EE} .
5. All unused outputs are loaded with 50Ω to GND.
6. $C_L =$ fixture and stray capacitance $\leq 3 \text{ pF}$.

FIGURE 5. Test circuit and switching waveforms - Continued.

STANDARD MICROCIRCUIT DRAWING DEFENSE SUPPLY CENTER COLUMBUS COLUMBUS, OHIO 43216-5000	SIZE A		5962-94591
		REVISION LEVEL A	SHEET 12

4.2 Screening. For device classes Q and V, screening shall be in accordance with MIL-PRF-38535, and shall be conducted on all devices prior to qualification and technology conformance inspection. For device class M, screening shall be in accordance with method 5004 of MIL-STD-883, and shall be conducted on all devices prior to quality conformance inspection.

4.2.1 Additional criteria for device class M.

- a. Burn-in test, method 1015 of MIL-STD-883.
 - (1) Test condition A, B, C, or D. The test circuit shall be maintained by the manufacturer under document revision level control and shall be made available to the preparing or acquiring activity upon request. The test circuit shall specify the inputs, outputs, biases, and power dissipation, as applicable, in accordance with the intent specified in test method 1015.
 - (2) $T_A = +125^{\circ}\text{C}$, minimum.
- b. Interim and final electrical test parameters shall be as specified in table II herein.

4.2.2 Additional criteria for device classes Q and V.

- a. The burn-in test duration, test condition and test temperature, or approved alternatives shall be as specified in the device manufacturer's QM plan in accordance with MIL-PRF-38535. The burn-in test circuit shall be maintained under document revision level control of the device manufacturer's Technology Review Board (TRB) in accordance with MIL-PRF-38535 and shall be made available to the acquiring or preparing activity upon request. The test circuit shall specify the inputs, outputs, biases, and power dissipation, as applicable, in accordance with the intent specified in test method 1015 of MIL-STD-883.
- b. Interim and final electrical test parameters shall be as specified in table II herein.
- c. Additional screening for device class V beyond the requirements of device class Q shall be as specified in MIL-PRF-38535, appendix B.

4.3 Qualification inspection for device classes Q and V. Qualification inspection for device classes Q and V shall be in accordance with MIL-PRF-38535. Inspections to be performed shall be those specified in MIL-PRF-38535 and herein for groups A, B, C, D, and E inspections (see 4.4.1 through 4.4.4).

4.4 Conformance inspection. Technology conformance inspection for classes Q and V shall be in accordance with MIL-PRF-38535 including groups A, B, C, D, and E inspections and as specified. Quality conformance inspection for device class M shall be in accordance with MIL-PRF-38535, appendix A and as specified herein. Inspections to be performed for device class M shall be those specified in method 5005 of MIL-STD-883 and herein for groups A, B, C, D, and E inspections (see 4.4.1 through 4.4.4).

4.4.1 Group A inspection.

- a. Tests shall be as specified in table II herein.
- b. Subgroups 4, 5, and 6 in table I, method 5005 of MIL-STD-883 shall be omitted.
- c. For device class M, subgroups 7 and 8 tests shall be sufficient to verify the truth table. For device classes Q and V, subgroups 7 and 8 shall include verifying the functionality of the device.

4.4.2 Group C inspection. The group C inspection end-point electrical parameters shall be as specified in table II herein.

STANDARD MICROCIRCUIT DRAWING DEFENSE SUPPLY CENTER COLUMBUS COLUMBUS, OHIO 43216-5000	SIZE A		5962-94591
		REVISION LEVEL A	SHEET 13

TABLE II. Electrical test requirements.

Test requirements	Subgroups (in accordance with MIL-STD-883, method 5005, table I)	Subgroups (in accordance with MIL-PRF-38535, table III)	
	Device class M	Device class Q	Device class V
Interim electrical parameters (see 4.2)	1	1	1
Final electrical parameters (see 4.2)	<u>1/</u> 1, 2, 3, 7, 8, 9	<u>1/</u> 1, 2, 3, 7, 8, 9, 10, 11	<u>2/</u> 1, 2, 3, 7, 8, 9, 10, 11
Group A test requirements (see 4.4)	1, 2, 3, 7, 8, 9, 10, 11	1, 2, 3, 7, 8, 9, 10, 11	1, 2, 3, 7, 8, 9, 10, 11
Group C end-point electrical parameters (see 4.4)	1, 2, 3	1, 2, 3, 7, 8	1, 2, 3, 7, 8,
Group D end-point electrical parameters (see 4.4)	1, 2, 3	1, 2, 3, 7, 8	1, 2, 3, 7, 8
Group E end-point electrical parameters (see 4.4)	1, 7, 9	1, 7, 9	1, 7, 9

1/ PDA applies to subgroup 1.

2/ PDA applies to subgroups 1 and 7.

4.4.2.1 Additional criteria for device class M. Steady-state life test conditions, method 1005 of MIL-STD-883:

- a. Test condition A, B, C, or D. The test circuit shall be maintained by the manufacturer under document revision level control and shall be made available to the preparing or acquiring activity upon request. The test circuit shall specify the inputs, outputs, biases, and power dissipation, as applicable, in accordance with the intent specified in test method 1005 of MIL-STD-883.
- b. $T_A = +125^\circ\text{C}$, minimum.
- c. Test duration: 1,000 hours, except as permitted by method 1005 of MIL-STD-883.

4.4.2.2 Additional criteria for device classes Q and V. The steady-state life test duration, test condition and test temperature, or approved alternatives shall be as specified in the device manufacturer's QM plan in accordance with MIL-PRF-38535. The test circuit shall be maintained under document revision level control by the device manufacturer's TRB in accordance with MIL-PRF-38535 and shall be made available to the acquiring or preparing activity upon request. The test circuit shall specify the inputs, outputs, biases, and power dissipation, as applicable, in accordance with the intent specified in test method 1005 of MIL-STD-883.

4.4.3 Group D inspection. The group D inspection end-point electrical parameters shall be as specified in table II herein.

4.4.4 Group E inspection. Group E inspection is required only for parts intended to be marked as radiation hardness assured (see 3.5 herein).

- a. End-point electrical parameters shall be as specified in table II herein.

STANDARD MICROCIRCUIT DRAWING DEFENSE SUPPLY CENTER COLUMBUS COLUMBUS, OHIO 43216-5000	SIZE A		5962-94591
		REVISION LEVEL A	SHEET 14

- b. For device classes Q and V, the devices or test vehicle shall be subjected to radiation hardness assured tests as specified in MIL-PRF-38535 for the RHA level being tested. For device class M, the devices shall be subjected to radiation hardness assured tests as specified in MIL-PRF-38535, appendix A for the RHA level being tested. All device classes must meet the post-irradiation end-point electrical parameter limits as defined in table I at $T_A = +25^{\circ}\text{C} \pm 5^{\circ}\text{C}$, after exposure, to the subgroups specified in table II herein.

4.4.4.1 Total dose irradiation testing. Total dose irradiation testing shall be performed in accordance with MIL-STD-883 method 1019, condition A and as specified herein.

5. PACKAGING

5.1 Packaging requirements. The requirements for packaging shall be in accordance with MIL-PRF-38535 for device classes Q and V or MIL-PRF-38535, appendix A for device class M.

6. NOTES

6.1 Intended use. Microcircuits conforming to this drawing are intended for use for Government microcircuit applications (original equipment), design applications, and logistics purposes.

6.1.1 Replaceability. Microcircuits covered by this drawing will replace the same generic device covered by a contractor-prepared specification or drawing.

6.2 Configuration control of SMD's. All proposed changes to existing SMD's will be coordinated with the users of record for the individual documents. This coordination will be accomplished using DD Form 1692, Engineering Change Proposal.

6.3 Record of users. Military and industrial users should inform Defense Supply Center Columbus when a system application requires configuration control and which SMD's are applicable to that system. DSCC will maintain a record of users and this list will be used for coordination and distribution of changes to the drawings. Users of drawings covering microelectronic devices (FSC 5962) should contact DSCC-VA, telephone (614) 692-0544.

6.4 Comments. Comments on this drawing should be directed to DSCC-VA, Columbus, Ohio 43216-5000, or telephone (614) 692-0547.

6.5 Abbreviations, symbols, and definitions. The abbreviations, symbols, and definitions used herein are defined in MIL-PRF-38535 and MIL-HDBK-1331.

6.6 Sources of supply.

6.6.1 Sources of supply for device classes Q and V. Sources of supply for device classes Q and V are listed in QML-38535. The vendors listed in QML-38535 have submitted a certificate of compliance (see 3.6 herein) to DSCC-VA and have agreed to this drawing.

6.6.2 Approved sources of supply for device class M. Approved sources of supply for class M are listed in MIL-HDBK-103. The vendors listed in MIL-HDBK-103 have agreed to this drawing and a certificate of compliance (see 3.6 herein) has been submitted to and accepted by DSCC-VA.

STANDARD MICROCIRCUIT DRAWING DEFENSE SUPPLY CENTER COLUMBUS COLUMBUS, OHIO 43216-5000	SIZE A		5962-94591
		REVISION LEVEL A	SHEET 15

STANDARD MICROCIRCUIT DRAWING BULLETIN

DATE: 04-03-15

Approved sources of supply for SMD 5962-94591 are listed below for immediate acquisition information only and shall be added to MIL-HDBK-103 and QML-38535 during the next revision. MIL-HDBK-103 and QML-38535 will be revised to include the addition or deletion of sources. The vendors listed below have agreed to this drawing and a certificate of compliance has been submitted to and accepted by DSCC-VA. This bulletin is superseded by the next dated revision of MIL-HDBK-103 and QML-38535.

Standard microcircuit drawing PIN <u>1/</u>	Vendor CAGE number	Vendor similar PIN <u>2/</u>
5962-9459101MXA	27014	100341DMQB
5962-9459101VXA	27014	100341J-QMLV
5962-9459101MYA	27014	100341FMQB
5962-9459101VYA	27014	100341W-QMLVB
5962F9459101VYA	27014	100341WFQMLV

1/ The lead finish shown for each PIN representing a hermetic package is the most readily available from the manufacturer listed for that part. If the desired lead finish is not listed contact the vendor to determine its availability.

2/ Caution. Do not use this number for item acquisition. Items acquired to this number may not satisfy the performance requirements of this drawing.

Vendor CAGE
number

Vendor name
and address

27014

National Semiconductor
2900 Semiconductor Drive
P.O. Box 58090
Santa Clara, CA 95052-8090

The information contained herein is disseminated for convenience only and the Government assumes no liability whatsoever for any inaccuracies in the information bulletin.