

The Constituents of Semiconductor Components

Responsible electronic component and equipment manufacturers are already preparing for the time when the lifespan of their products comes to an end by scrutinizing the materials incorporated and their future recyclability. Recycling laws have already come into force in Germany ("Kreislauf-Wirtschaftsgesetz") and guidelines for electronic scrap are in preparation.

The aim is a suitable waste disposal program and _ as a preventative measure _ a reduction in the content of hazardous damaging materials in such components. In order to conform to this procedure, detailed information about the materials and their quantities is needed.

This present overview answers questions put forward by customers as to the constituents and their function in the most important of Vishay Semiconductor's semiconductor products. Special significance is given to so-called "Hazardous Substances". It demonstrates that Vishay Semiconductor products under normal operating conditions do not expose the applier or environment to any hazard. However, most products nevertheless contain small but necessary quantities of "Hazardous Substances" which can _ if not treated correctly or through accidents _ be released on a small scale into the environment.

The present information was produced with the greatest possible care. Any suggestions for improvement of this brochure are welcome.

Definitions

Vishay Semiconductor offers a wide range of semiconductor components including transistors, diodes and opto-electronic components. These have been manufactured in various standard packages. On the following pages, these packages are listed together with their materials shown in weight percentages. In order to limit the number of tables, all components whose structure and composition are the same have been compiled in families. In many cases, different lead frames together with chips of different sizes may be used for the one package. This usually means that there may be slight differences in the quantities of the declared material. The weight percent is, however, valid for a representative sample of the relevant family. In order to sensibly reduce the number and quantities of materials contained in the respective components, quantities smaller than 0.1% by weight have been stated in the following list as **traces**. This is the case unless lower limits are forced by law, e.g., cadmium < 75 ppm and PCDD as well as PCDF

(known as dioxin) < 2 ppb. In the lists themselves, details of content and composition are separated into the individual parts of the semiconductor component. The most important of these are:

Active element: The active element is either a silicon chip or for optoelectronic components a chip containing combinations of Ga (Al) (As, P). These are doped with very small amounts of boron, arsenic, phosphorus, zinc and germanium etc. The metallization consists of thin layers of aluminium, gold or titanium. The chips are generally bonded to the lead frame with a silver epoxy and have gold or aluminium wires bonded to the lead frame.

Lead frame: For electrical connection, a metal lead frame made from alloys such as FeNi (42) or CuFe (2) and partly or totally plated with silver is commonly used. The metal alloys contain traces of silver, zinc and phosphorus.

Case: The semiconductor chip is protected from the environment by a case of glass, plastic or metal. The glass is composed of oxides of silicon and lead together with boron and aluminium. Plastic cases are composed of an epoxy resin filled with up to 70 % by weight of quartz particles. Antimony trioxide and brominated epoxy resin (no TBA) are added as flame retardants. Antimony and bromine amount to about 1.6 and 1.0 % respectively.

In use: In use, it is the content of hazardous substances which is of importance. In Germany, there are a series of lists which give the materials which are potentially hazardous to people and the environment, for example:

Appendix II and IV of the "Hazardous Materials Regulations", the TRGS 900 ("MAK-Wert-Liste") and the "Catalog of Materials Hazardous to the Water Supply". These lists, however, are only partially consistent.

The names used are often different for materials with the same chemical composition. Furthermore, the use of trivial and trade names often adds to the confusion.

Vishay Semiconductor therefore for their descriptions use that proposed by the Zentralverband Elektrotechnik und Elektronikindustrie e.V. (ZVEI; Central Association of Electrical Engineering and Electronic Industry) for the harmonization of the nomenclature of hazardous substances.

Statements are made on the safety precautions to be used during storage and disposal by mechanical, chemical and thermal means of the more important

Vishay Semiconductors

chemicals (so-called "Leitchemikalien"). These are listed in the tables in the order of their potential risk. Their effect upon people and the environment are also listed and any special precautions emphasized.

Notes: The following information has been prepared to be as exact and reliable as possible.

The manufacture of semiconductor components is, however, subject to regular change without special notification.

The publication of this brochure excludes any responsibility resulting from its use.

Explanation of Abbreviations

While the information on weight percent is believed correct, discrepancies depending upon component type may be possible.

- 1) Material information etc. Material listed as "Material Hazardous in Production"
- 2) S: Trace material < 0.1% by weight;
Cd < 75 ppm; concerning Cd see ***)
PCDD and PCDF < 2 ppb
- *) Dioxin content – lies below agreed limits
- **) No. 85 "Rules for Hazardous Materials", to be replaced as soon as a technically suitable alternative material is available
- ***) Traces of cadmium can only be found in lead frames made of copper

CMT: Material containing carcinogens, mutagens or terratogens

Tox: Material is toxic or very toxic

S Material with allergy producing characteristics

HAL Halogen containing material

WKG Material hazardous to the water supply

L Storage, suitable for disposal

D Disposable

M Mechanical disposal

N Chemical disposal

T Thermal disposal

H Handling

Ozone Depleting Substances

The use of Ozone Depleting Substances has been totally eliminated by Vishay Semiconductor and by doing so meets the legal requirements as defined in the following documents.

1. The "Montreal Protocol" together with the "London Amendments" Appendix A, B, and the "List of Transitional Substances"
2. "Clean Air Act", Amendments 1990, "Environmental Protection Agency" (EPA), USA, Class I and II – Ozone Depleting Substances
3. "European Council Resolution" number 88/540/EEC and 91/690/eec Appendix A, B and C (Transitional Substances)

Vishay Semiconductor guarantees that its components do not contain and are manufactured without the use of Ozone Depleting Substances.

Declaration of Material Contents DO-214 Package

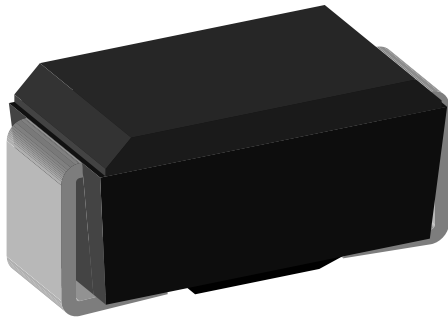

DO-214 Diode

Prohibited Substances		
Material	Limit ppm	ICP Analysis < ppm
Cadmium	5	5
Asbestos	0	0
Mercury	0	0
Chromium VI	2	0
Polychl. Biphenyle	0	0
Formaldehyde	0	0
Azo Compounds	0	0

MATERIAL CONTENT					
Part	Material	weight mg	% of weight	ppm of total weight	CAS N°
Mold 50.40 %	SiO ₂	27.6	71.39 %	360739	14808-60-7
	epoxy resin	10.05	26.00 %	131356	25928-94-3
	Sb ₂ O ₃	0.62	1.60 %	8104	1309-64-4
	Br	0.39	1.01 %	5097	7726-95-6
	TOTAL	38.66			
Lead frame tinned 46.20 %	Cu	30.05	85.13 %	392761	7440-50-8
	Fe	3.3	9.35 %	43132	7439-89-6
	Sn	1.95	5.52 %	25487	7440-31-5
	TOTAL	35.3			
Solder dip 1.30 %	Pb	0.8774	89.78 %	11468	7439-92-1
	Sn	0.997	10.20 %	1303	7440-31-5
	Ag	0.0002	0.02 %	3	7440-22-4
	TOTAL	0.98			
Silicon chip 2.10 %	Si	1.2925	82.20 %	16893	7440-21-3
	Ag	0.2406	15.30 %	3145	7440-22-4
	Ni	0.0031	0.20 %	41	7440-02-0
	SiO ₂	0.0362	2.30 %	473	14808-60-7
	TOTAL	1.57			
Total weight		77			

Vishay Semiconductors

Declaration of Material Contents SOD-80 Package

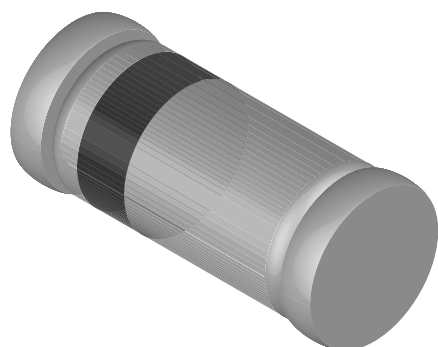

minimelf

MiniMELF Diode

Prohibited Substances		
Material	Limit ppm	ICP Analysis < ppm
Cadmium	5	5
Asbestos	0	0
Mercury	0	0
Chromium VI	2	0
Polychl. Biphenyle	0	0
Formaldehyde	0	0
Azo Compounds	0	0

MATERIAL CONTENT					
Part	Material	weight mg	% of weight	ppm of total weight	CAS N°
Leads Tinned 58.60 %	Fe	11.03	61.38 %	359138	7439-89-6
	Cu	4.86	27.05 %	158242	7440-50-8
	Ni	1.55	8.63 %	50468	7440-02-0
	Sn	0.48	2.67 %	15629	7440-31-5
	CuO	0.05	0.28 %	1628	1317-38-0
	TOTAL	17.97			
Package Glass 41.10 %	PbO	7.96	62.92 %	259179	1317-36-8
	SiO ₂	3.46	27.35 %	112658	14808-60-7
	K ₂ O	0.97	7.67 %	31583	12136-45-7
	Na ₂ O	0.09	0.71 %	2930	1313-59-3
	Al ₂ O ₃	0.09	0.71 %	2930	1344-28-1
	BaO	0.08	0.63 %	2605	1304-28-5
TOTAL	12.65				
Silicon Chip 0.30 %	Si	0.0741	80.19 %	2413	7440-21-3
	Ag	0.0153	16.56 %	498	7440-22-4
	SiO ₂	0.0015	1.62 %	49	14808-60-7
	PbO	0.0013	1.41 %	42	1317-36-8
	Ni	0.0002	0.22 %	7	7440-02-0
	TOTAL	0.0924			
Total weight	31				

Declaration of Material Contents SOD-80 Q Package

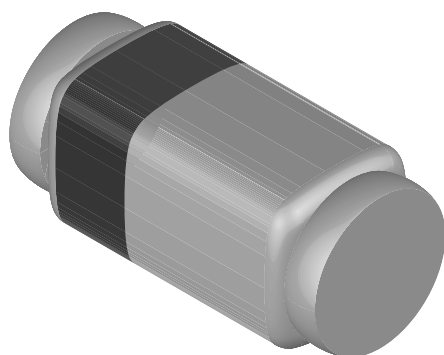

quadromelf

QuadromELF Diode

Prohibited Substances		
Material	Limit ppm	ICP Analysis < ppm
Cadmium	5	5
Asbestos	0	0
Mercury	0	0
Chromium VI	2	0
Polychl. Biphenyle	0	0
Formaldehyde	0	0
Azo Compounds	0	0

MATERIAL CONTENT					
Part	Material	weight mg	% of weight	ppm of total weight	CAS N°
Leads Tinned 53.50 %	Fe	11.02	61.39 %	327965	7439-89-6
	Cu	4.85	27.02 %	144341	7440-50-8
	Ni	1.55	8.64 %	46129	7440-02-0
	Sn	0.48	2.67 %	14285	7440-31-5
	CuO	0.05	0.28 %	1488	1317-38-0
	TOTAL	17.95			
Package Glass 46.20 %	PbO	9.79	62.96 %	291360	1317-36-8
	SiO ₂	4.25	27.33 %	126484	14808-60-7
	K ₂ O	1.2	7.72 %	35713	12136-45-7
	Na ₂ O	0.11	0.71 %	3274	1313-59-3
	Al ₂ O ₃	0.11	0.71 %	3274	1344-28-1
	BaO	0.09	0.58 %	2678	1304-28-5
TOTAL	15.55				
Silicon Chip 0.30 %	Si	0.0811	80.22 %	2414	7440-21-3
	Ag	0.0168	16.62 %	500	7440-22-4
	SiO ₂	0.0016	1.58 %	48	14808-60-7
	PbO	0.0014	1.38 %	42	1317-36-8
	Ni	0.0002	0.20 %	6	7440-02-0
	TOTAL	0.101			
Total weight	34				

Declaration of Material Contents MicroMELF Package

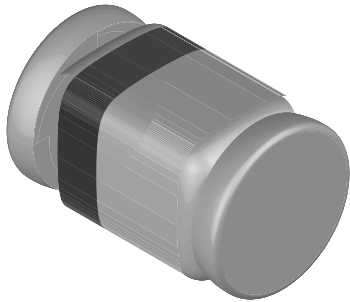

micromelf

MicroMELF Diode

Prohibited Substances		
Material	Limit ppm	ICP Analysis < ppm
Cadmium	5	5
Asbestos	0	0
Mercury	0	0
Chromium VI	2	0
Polychl. Biphenyle	0	0
Formaldehyde	0	0
Azo Compounds	0	0

MATERIAL CONTENT					
Part	Material	weight mg	% of weight	ppm of total weight	CAS N°
Leads Tinned 57.70 %	Fe	4.39	62.01 %	357716	7439-89-6
	Cu	1.97	27.82 %	160524	7440-50-8
	Ni	0.62	8.76 %	50520	7440-02-0
	Sn	0.09	1.27 %	7334	7440-31-5
	CuO	0.01	0.14 %	815	1317-38-0
	TOTAL	7.08			
Package Glass 41.50 %	PbO	3.21	62.94 %	261565	1317-36-8
	SiO ₂	1.39	27.25 %	113263	14808-60-7
	K ₂ O	0.39	7.65 %	31779	12136-45-7
	Na ₂ O	0.04	0.78 %	3259	1313-59-3
	Al ₂ O ₃	0.04	0.78 %	3259	1344-28-1
	BaO	0.03	0.59 %	2445	1304-28-5
	TOTAL	5.1			
Silicon Chip 0.80 %	Si	0.074	80.17 %	6030	7440-21-3
	Ag	0.0153	16.58 %	1247	7440-22-4
	SiO ₂	0.0015	1.63 %	122	14808-60-7
	PbO	0.0013	1.41 %	106	1317-36-8
	Ni	0.0002	0.22 %	16	7440-02-0
	TOTAL	0.0923			
Total weight	12.3				

Vishay Semiconductors

Declaration of Material Contents DO-35 Package

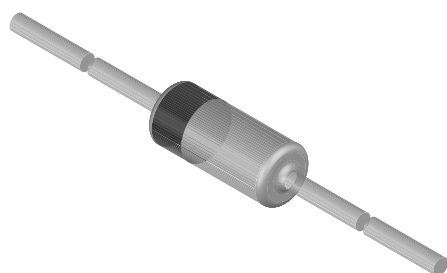

do35

DO-35 Diode

Prohibited Substances		
Material	Limit ppm	ICP Analysis < ppm
Cadmium	5	5
Asbestos	0	0
Mercury	0	0
Chromium VI	2	0
Polychl. Biphenyle	0	0
Formaldehyde	0	0
Azo Compounds	0	0

MATERIAL CONTENT					
Part	Material	weight mg	% of weight	ppm of total weight	CAS N°
Leads tinned 85.70 %	Fe	67.17	62.74 %	537037	7439-89-6
	Cu	29.78	27.82 %	238097	7440-50-8
	Ni	9.43	8.81 %	75395	7440-02-0
	Sn	0.57	0.53 %	4557	7440-31-5
	CuO	0.11	0.10 %	879	1317-38-0
	TOTAL	107.1			
Package glass 14.30 %	PbO	11.24	62.83 %	89866	1317-36-8
	SiO ₂	4.9	27.39 %	39176	14808-60-7
	K ₂ O	1.38	7.71 %	11033	12136-45-7
	Na ₂ O	0.13	0.73 %	1039	1313-59-3
	Al ₂ O ₃	0.13	0.73 %	1039	1344-28-1
	BaO	0.11	0.61 %	879	1304-28-5
	TOTAL	17.9			
Silicon chip 0.10 %	Si	0.1003	80.11 %	802	7440-21-3
	Ag	0.0208	16.60 %	166	7440-22-4
	SiO ₂	0.002	1.60 %	16	14808-60-7
	PbO	0.0018	1.40 %	14	1317-36-8
	Ni	0.0003	0.20 %	2	7440-02-0
	TOTAL	0.125			
Total weight		125			

Declaration of Material Contents DO-41 Package

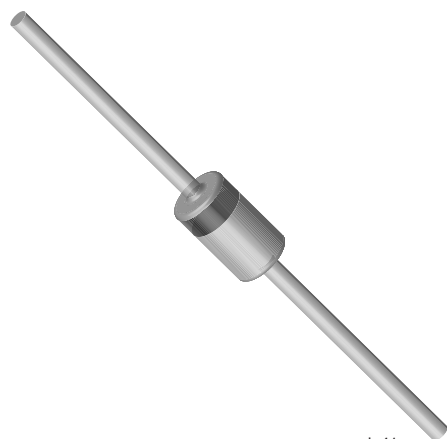

do41

DO-41 Diode

Prohibited Substances		
Material	Limit ppm	ICP Analysis < ppm
Cadmium	5	5
Asbestos	0	0
Mercury	0	0
Chromium VI	2	0
Polychl. Biphenyle	0	0
Formaldehyde	0	0
Azo Compounds	0	0

MATERIAL CONTENT					
Part	Material	weight mg	% of weight	ppm of total weight	CAS N°
Leads tinned 85.70 %	Fe	166.58	62.75 %	537147	7439-89-6
	Cu	73.86	27.82 %	238166	7440-50-8
	Ni	23.38	8.81 %	75390	7440-02-0
	Sn	1.39	0.52 %	4482	7440-31-5
	CuO	0.27	0.10 %	871	1317-38-0
	TOTAL	265.48			
Package glass 14.30 %	PbO	27.88	62.89 %	89901	1317-36-8
	SiO ₂	12.15	27.41 %	39178	14808-60-7
	K ₂ O	3.41	7.69 %	10996	12136-45-7
	Na ₂ O	0.31	0.70 %	1000	1313-59-3
	Al ₂ O ₃	0.31	0.70 %	1000	1344-28-1
	BaO	0.27	0.61 %	871	1304-28-5
	TOTAL	44.33			
Silicon chip 0.10 %	Si	0.2523	81.41 %	814	7440-21-3
	Ag	0.0474	15.30 %	153	7440-22-4
	SiO ₂	0.0053	1.71 %	17	14808-60-7
	PbO	0.0043	1.39 %	14	1317-36-8
	Ni	0.0006	0.19 %	2	7440-02-0
	TOTAL	0.3099			
Total weight		310.1199			

Declaration of Material Contents DO-41 Plastic Package

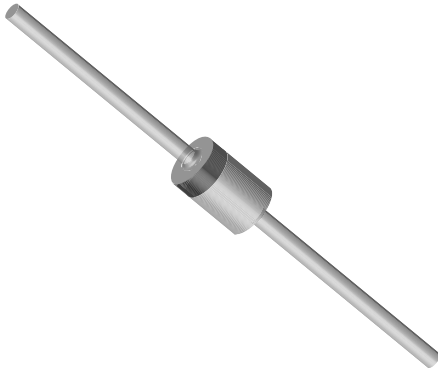

do204am

DO-41 Plastic Diode

Prohibited Substances		
Material	Limit ppm	ICP Analysis < ppm
Cadmium	5	5
Asbestos	0	0
Mercury	0	0
Chromium VI	2	0
Polychl. Biphenyle	0	0
Formaldehyde	0	0
Azo Compounds	0	0

MATERIAL CONTENT					
Part	Material	weight mg	% of weight	ppm of total weight	CAS N°
Leads tinned 85.6 %	Cu	283.8	96.3 %	825000	7440-50-7
	Sn	10.8	3.7 %	31395	7439-92-1
	TOTAL	294.6			
Solder pellet 0.5 %	Pb	1.57	92.4 %	4564	7440-31-5
	Sn	0.09	5.3 %	262	7439-92-1
	Ag	0.04	2.4 %	116	7440-22-4
	TOTAL	1.7			
Chip 0.3 %	Si	0.896	0.3 %	2605	7440-21-3
	SiO ₂	0.004	0.0 %	12	14808-60-7
	And / or traces of Au, As, Ag, Ti, Al, Ni, Pd, Cu				
TOTAL	0.9				
Coating 0.3 %	Elastomer	1.2	100.0 %	3488	
	TOTAL	1.2			
Molding (Epoxy) 13.3 %	Silica, vitreous	32.457	11.0 %	94352	60676-86-0
	Epikote 862	9.12	3.1 %	26512	28064-14-4
	Phenolic resin	3.42	1.2 %	9942	9003-35-4
	Antimony oxide	0.364	0.1 %	1058	1309-64-4
	Carbon black	0.137	0.0 %	398	1333-86-4
	Cristobalite	0.102	0.0 %	297	14464-46-1
	Arsenic	Trace			7440-38-2
	Lead	Trace			7439-92-1
	TOTAL	45.6			
	Total weight	344			

Declaration of Material Contents SOD-57 Package

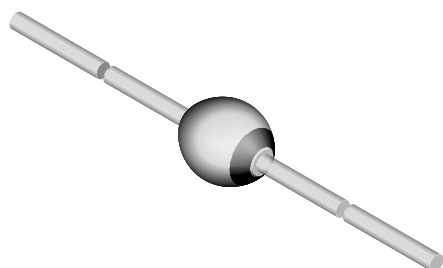

sod57

SOD-57 Diode

Prohibited Substances		
Material	Limit ppm	ICP Analysis < ppm
Cadmium	5	5
Asbestos	0	0
Mercury	0	0
Chromium VI	2	0
Polychl. Biphenyle	0	0
Formaldehyde	0	0
Azo Compounds	0	0

MATERIAL CONTENT					
Part	Material	weight mg	% of weight	ppm of total weight	CAS N°
Leads tinned 85.90 %	Cu	184.98	58.36 %	501111	7440-50-8
	Fe	70.24	22.16 %	190280	7439-89-6
	Mo	58.8	18.55 %	159289	7439-98-7
	Sn	1.99	0.63 %	5391	7440-31-5
	Ag	0.32	0.10 %	867	7440-22-4
	C	0.32	0.10 %	867	7440-44-0
	O ₂	0.32	0.10 %	867	7782-44-7
	TOTAL	316.97			
Package glass 13.80 %	PbO	21.45	42.01 %	58108	1317-36-8
	SiO ₂	19.4	37.99 %	52555	14808-60-7
	B ₂ O ₃	7.66	15.00 %	20751	1303-86-2
	Al ₂ O ₃	2.55	4.99 %	6908	1344-28-1
	TOTAL	51.06			
Silicon chip 0.30 %	Si	0.999	90.00 %	2706	7440-21-3
	Al	0.111	10.00 %	301	7429-90-5
	TOTAL	1.11			
Total weight		369.14			

Declaration of Material Contents SOD-64 Package

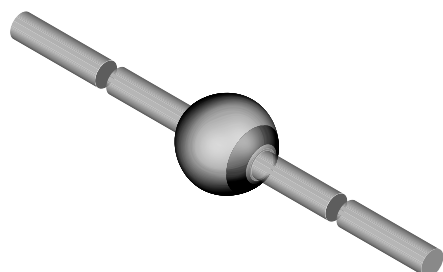

sod64

SOD-64 Diode

Prohibited Substances		
Material	Limit ppm	ICP Analysis < ppm
Cadmium	5	5
Asbestos	0	0
Mercury	0	0
Chromium VI	2	0
Polychl. Biphenyle	0	0
Formaldehyde	0	0
Azo Compounds	0	0

MATERIAL CONTENT					
Part	Material	weight mg	% of weight	ppm of total weight	CAS N°
Leads tinned 85.90 %	Cu	429.95	58.35 %	501078	7440-50-8
	Fe	163.26	22.16 %	190269	7439-89-6
	Mo	136.67	18.55 %	159280	7439-98-7
	Sn	4.69	0.64 %	5466	7440-31-5
	Ag	0.74	0.10 %	862	7440-22-4
	C	0.74	0.10 %	862	7440-44-0
	O ₂	0.74	0.10 %	862	7782-44-7
	TOTAL	736.79			
Package glass 13.80 %	PbO	49.85	42.00 %	58097	1317-36-8
	SiO ₂	45.1	38.00 %	52561	14808-60-7
	B ₂ O ₃	17.8	15.00 %	20745	1303-86-2
	Al ₂ O ₃	5.93	5.00 %	6911	1344-28-1
	TOTAL	118.68			
Silicon chip 0.30 %	Si	2.322	90.00 %	2706	7440-21-3
	Al	0.258	10.00 %	301	7429-90-5
	TOTAL		2.58		
Total weight		858			

Declaration of Material Contents SMF (DO-219AB) Package

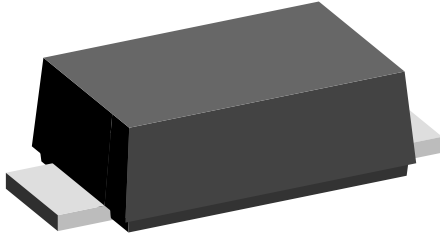

SMF Diode

smf

Prohibited Substances		
Material	Limit ppm	ICP Analysis < ppm
Cadmium	5	5
Asbestos	0	0
Mercury	0	0
Chromium VI	2	0
Polychl. Biphenyle	0	0
Formaldehyde	0	0
Azo Compounds	0	0

MATERIAL CONTENT						
Part	Material	weight mg	% of weight	ppm of total weight	CAS N°	
Lead frame tinned 44.3 %	Cu	6.198	94.34 %	418311	7440-50-8	
	Fe	0.153	2.32 %	10302	7439-89-6	
	Zn	0.008	0.12 %	515	7440-66-6	
	P	0.002	0.03 %	129	7723-14-0	
	Sn	0.210	3.20 %	14174	7440-31-5	
	TOTAL	6.57				
Solder paste (chip solder) 1.1 %	Pb	0.142	90.85 %	9584	7439-92-1	
	Sn	0.005	3.07 %	324	7440-31-5	
	Ag	0.003	2.11 %	223	7440-22-4	
	Hexylene-glyco	0.006	3.97 %	418	107-41-5	
	TOTAL	0.16				
Silicon chip 3.2 %	Si	0.468	99.57 %	31587	7440-21-3	
	Silicon dioxide	0.002	0.43 %	135	14808-60-7	
	And/or traces of Au,As,Ti,Ag,Al, Ni, Pd, Cu					
	TOTAL	0.47				
Molding compound 51.4 %	Cristalline Silica	5.258	69.00 %	354866	14808-60-7	
	Polyglycidyl ether	1.143	15.00 %	77145	29690-82-2	
	Phenolic resin	0.533	7.00 %	36001	9003-35-4	
	Brominated epoxy resin	0.229	3.00 %	15429	40039-93-8	
	Organofunctional silan	0.076	1.00 %	5143	2530-83-8	
	Antimony trioxid	0.229	3.00 %	15429	1309-64-4	
	Wax	0.076	1.00 %	5143	8015-86-9	
	Catalyst	0.076	1.00 %	5143	603-35-0	
	TOTAL	7.62				
	Total weight	14.8				

Declaration of Material Contents SOT-23 Package

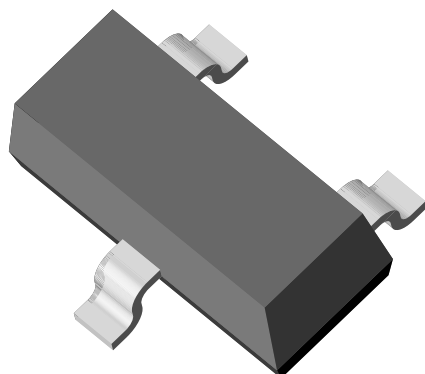

SOT-23 Diode

Prohibited Substances		
Material	Limit ppm	ICP Analysis < ppm
Cadmium	5	5
Asbestos	0	0
Mercury	0	0
Chromium VI	2	0
Polychl. Biphenyle	0	0
Formaldehyde	0	0
Azo Compounds	0	0

MATERIAL CONTENT					
Part	Material	weight mg	% of weight	ppm of total weight	CAS N°
Lead frame tinned 31.9 %	Cu	2.7	96.2 %	306954	7440-50-8
	Sn	0.02	0.7 %	2274	7440-31-5
	Ni	0.01	0.4 %	1137	7440-02-0
	Cr	0.008	0.3 %	909	7440-47-3
	Ti	0.008	0.3 %	909	7440-32-6
	Sn	0.06	2.1 %	6821	7440-31-5
	TOTAL		2.81		
Moulding (PPS, Polyphenylene Sulfide) 61.4 %	Mineral reinforcement	2.97	55.00 %	337650	
	1,4- Dichlorobenzene	0.00054	0.01 %	61	25321-22-6
	Other + Carbon black + Silicon dioxide	2.43	44.99 %	276197	1333-86-4 + 14808-60-7
	TOTAL		5.4		
Glue 0.7 %	Silver powder	0.04215	70.3 %	4792	7440-22-4
	Hardener and epoxy resin	0.01785	29.8 %	2029	
	TOTAL		0.06		
Chip 1.1 %	Si	0.0996	99.60 %	11323	7440-21-3
	SiO ₂	0.0004	0.40 %	45	14808-60-7
	And / or traces of Au, As, Ag, Ti, Al, Ni, Pd, Cu				
TOTAL		0.1			
Bond wire 0.3 %	Au	0.03	100 %	3411	7440-57-5
	TOTAL		0.03		
Bond wire coating (Epoxy resin) 4.5 %	Benzophenonetetra carboxylic acid dianhydride	0.12	30.0 %	13642	2421-28-5
	Quartz	0.002	0.5 %	227	14808-60-7
	Cristobalite	0.0012	0.3 %	136	14464-46-1
	Silica	0.12	30.0 %	13642	60676-86-0
	Carbon black	0.004	1.0 %	455	1333-86-4
	Epichlorohydrin	0.00002	0.005 %	2	106-89-8
	Other (harmless addition)	0.15288	38.2 %	17380	
	TOTAL		0.40		
Total weight		8.8			

Declaration of Material Contents SOD-123 Package

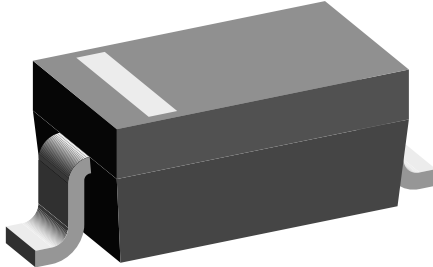

sod123

SOD-123 Diode

Prohibited Substances		
Material	Limit ppm	ICP Analysis < ppm
Cadmium	5	5
Asbestos	0	0
Mercury	0	0
Chromium VI	2	0
Polychl. Biphenyle	0	0
Formaldehyde	0	0
Azo Compounds	0	0

MATERIAL CONTENT					
Part	Material	weight mg	% of weight	ppm of total weight	CAS N°
Lead frame tinned 29.4 %	Cu	2.6	95.7 %	280869	7440-50-8
	Sn	0.015	0.6 %	1620	7440-31-5
	Ni	0.01	0.4 %	1080	7440-02-0
	Cr	0.007	0.3 %	756	7440-47-3
	Ti	0.007	0.3 %	756	7440-32-6
	Sn	0.078	2.9 %	8426	7440-31-5
	TOTAL		2.72		
Moulding (PPS, Polyphenylene Sulfide) 64.8 %	Mineral reinforcement	3.3	55.00 %	356487	
	1.4- Dichlorobenzene	0.0006	0.01 %	65	25321-22-6
	Other + Carbon black + Silicon dioxide	2.6994	44.99 %	291606	1333-86-4 + 14808-60-7
	TOTAL		6		
Glue 0.6 %	Silver powder	0.04215	70.3 %	4553	7440-22-4
	Hardener and epoxy resin	0.01785	29.8 %	1928	
	TOTAL		0.06		
Chip 0.9 %	Si	0.07968	99.60 %	8608	7440-21-3
	SiO2	0.00032	0.40 %	35	14808-60-7
	And / or traces of Au, As, Ag, Ti, Al, Ni, Pd, Cu				
	TOTAL		0.08		
Bond wire 0.3 %	Au	0.03	100 %	3241	7440-57-5
	TOTAL		0.03		
Bond wire coating (Epoxy resin) 4.0 %	Benzophenonetetra carboxylic acid dianhydride	0.12	32.4 %	12963	2421-28-5
	Quartz	0.002	0.5 %	216	14808-60-7
	Cristobalite	0.0012	0.3 %	130	14464-46-1
	Silica	0.12	32.4 %	12963	60676-86-0
	Carbon black	0.004	1.1 %	432	1333-86-4
	Epichlorohydrin	0.00002	0.005 %	2	106-89-8
	Other (harmless addition)	0.12278	33.2 %	13263	
	TOTAL		0.37		
Total weight		9.3			

Declaration of Material Contents SOD-323 Package

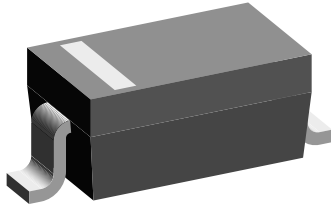

sod323

SOD-323 Diode

Prohibited Substances		
Material	Limit ppm	ICP Analysis < ppm
Cadmium	5	5
Asbestos	0	0
Mercury	0	0
Chromium VI	2	0
Polychl. Biphenyle	0	0
Formaldehyde	0	0
Azo Compounds	0	0

MATERIAL CONTENT					
Part	Material	weight mg	% of weight	ppm of total weight	CAS N°
Lead frame tinned 26.9 %	Cu	1.28	95.5%	256977	7440-50-8
	Sn	0.008	0.6%	1606	7440-31-5
	Ni	0.005	0.4%	1004	7440-02-0
	Cr	0.004	0.3%	803	7440-47-3
	Ti	0.004	0.3%	803	7440-32-6
	Sn	0.04	3.0%	8031	7440-31-5
	TOTAL	1.34			
Moulding (PPS, Polyphenylene Sulfide) 62.2 %	Mineral reinforcement	1.705	55.00%	342301	
	1.4-Dichlorobenzene	0.00031	0.01%	62	25321-22-6
	Other + Carbon black + Silicon dioxide	1.39	44.99%	280002	1333-86-4 + 14808-60-7
	TOTAL	3.1			
Glue 1.2 %	Silver powder	0.04215	70.3%	8462	7440-22-4
	Hardener and epoxyresin	0.01785	29.8%	3584	
	TOTAL	0.06			
Chip 1.6 %	Si	0.07968	99.60%	15997	7440-21-3
	SiO2	0.00032	0.40%	64	14808-60-7
	And / or traces of Au, As, Ag, Ti, Al, Ni, Pd, Cu				
	TOTAL	0.08			
Bond wire 0.6 %	Au	0.03	100%	6023	7440-57-5
	TOTAL	0.03			
Bond wire coating (Epoxy resin) 7.4 %	Benzophenonetetra carboxylic acid dianhydride	0.12	32.4%	24092	2421-28-5
	Quartz	0.002	0.5%	402	14808-60-7
	Cristobalite	0.0012	0.3%	241	14464-46-1
	Silica	0.12	32.4%	24092	60676-86-0
	Carbon black	0.004	1.1%	803	1333-86-4
	Epichlorohydrin	0.00002	0.005%	4	106-89-8
	Other (harmless addition)	0.12278	33.2%	24650	
TOTAL	0.37				
Total weight		5.0			

Declaration of Material Contents SOD-523 Package

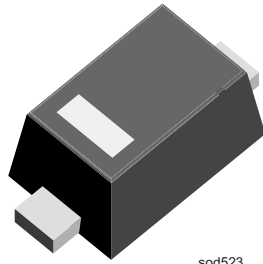

sod523

SOD-523 Diode

Prohibited Substances		
Material	Limit ppm	ICP Analysis < ppm
Cadmium	5	5
Asbestos	0	0
Mercury	0	0
Chromium VI	2	0
Polychl. Biphenyle	0	0
Formaldehyde	0	0
Azo Compounds	0	0

MATERIAL CONTENT					
Part	Material	weight mg	% of weight	ppm of total weight	CAS N°
Mold compound 53.2 %	SiO ₂	0.65	77.0 %	409882	14808-60-7
	epoxy resin	0.17	20.0 %	106463	25928-94-3
	Sb ₂ O ₃	0.026	3.0 %	15969	1309-64-4
	TOTAL	0.85			
Lead frame tinned 43.6 %	Cu	0.627	90.10 %	392660	7440-50-8
	Ag	0.015	2.16 %	9394	7440-22-4
	Sn	0.053	7.62 %	33191	7440-31-5
	Si	0.0001	0.01 %	63	7440-21-3
	Cr	0.000	0.03 %	125	7440-47-3
	Ti	0.001	0.09 %	376	7440-32-6
TOTAL	0.696				
Silicon chip 2.4 %	Si	0.034	89.71 %	21293	7440-21-3
	Au	0.0035	9.23 %	2192	7440-57-5
	SiO ₂	0.0002	0.53 %	125	14808-60-7
	Al	0.0002	0.53 %	125	7429-90-5
	And / or traces of Au, As, B, P, Pd, Sn, Ti, V, W				
TOTAL	0.038				
Bond wire 0.8 %	Au	0.013	100.0 %	8141	7440-57-5
	TOTAL	0.013			
Total weight		1.60			

Declaration of Material Contents SOT-363 Package

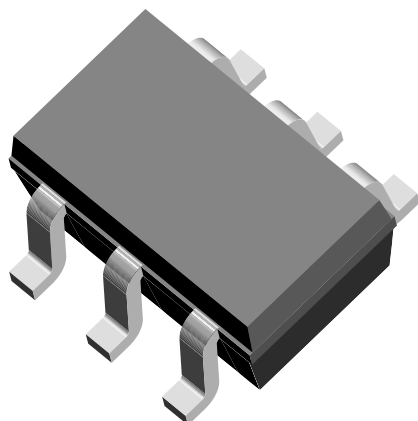

SOT-363 Diode

Prohibited Substances		
Material	Limit ppm	ICP Analysis < ppm
Cadmium	5	5
Asbestos	0	0
Mercury	0	0
Chromium VI	2	0
Polychl. Biphenyle	0	0
Formaldehyde	0	0
Azo Compounds	0	0

MATERIAL CONTENT					
Part	Material	weight mg	% of weight	ppm of total weight	CAS N°
Mold compound 57.10 %	SiO ₂	2.45	71.64 %	408401	14808-60-7
	epoxy resin	0.89	26.02 %	148358	25925-94-3
	Sb ₂ O ₃	0.05	1.46 %	8335	1309-64-4
	Br	0.03	0.88 %	5001	7726-95-6
	TOTAL	3.42			
Lead frame tinned 38.70 %	Cu	1.98	85.09 %	330055	7440-50-8
	Ag	0.23	9.88 %	38340	7440-22-4
	Sn	0.077	3.31 %	12835	7440-31.5
	Ni	0.02	0.86 %	3334	7440-02-0
	Cr	0.01	0.43 %	1667	7440-47-3
	Ti	0.01	0.43 %	1667	7440-32-6
TOTAL	2.33				
Silicon chip 3.90 %	Si	0.2188	93.50 %	36473	7440-21-3
	Au	0.0122	5.21 %	2034	7440-57-5
	SiO ₂	0.0012	0.51 %	200	14808-60-7
	Al	0.0009	0.38 %	150	7429-90-5
	Si ₃ N ₄	0.0009	0.38 %	150	12033-89-5
	TOTAL	0.23			
Bond wire 0.3 %	Au	0.018	100.0 %	3001	7440-57-5
	TOTAL	0.02	99.90 %		
Total weight		6			

Declaration of Material Contents LLP-75 Package

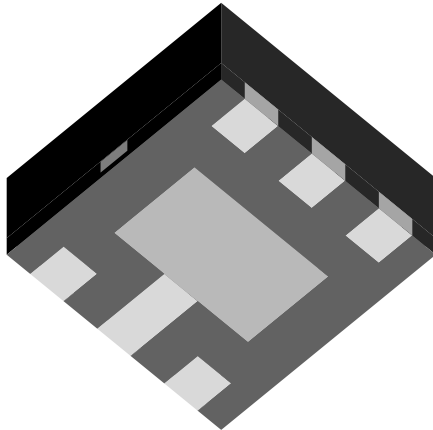

LLP-75 Diode

Prohibited Substances		
Material	Limit ppm	ICP Analysis < ppm
Cadmium	5	5
Asbestos	0	0
Mercury	0	0
Chromium VI	2	0
Polychl. Biphenyle	0	0
Formaldehyde	0	0
Azo Compounds	0	0

MATERIAL CONTENT					
Part	Material	weight mg	% of weight	ppm of total weight	CAS N°
Lead frame tinned 27.8 %	Cu	1.34	93.7 %	260189	7440-50-8
	Sn	0.003	0.2 %	660	7440-31-5
	Zn	0.003	0.2 %	583	7440-66-6
	Cr	0.003	0.2 %	660	7440-47-3
	Sn (plating)	0.08	5.6 %	15534	7440-31-5
TOTAL	1.43				
Moulding 63.3 %	Amorphous silica	2.608	79.99 %	506398	7631-86-3
	Others	0.463	14.20 %	89901	
	Epoxy resin	0.16	5.00 %	31650	25928-94-3
	Antimony trioxide	0.016	0.50 %	3165	1309-64-4
	Carbon black	0.01	0.31 %	1942	1333-86-3
TOTAL	3.2603				
Glue 1.7 %	Silver powde	0.063	70.2 %	12272	7440-22-4
	Hardener and epoxy resin	0.027	29.8 %	5204	
	TOTAL	0.09			
Chip 5.8 %	Si	0.299	99.60 %	58018	7440-21-3
	SiO2	0.001	0.40 %	233	14808-60-7
	And / or traces of Au, As, Ag, Ti, Al, Ni, Pd, Cu				
TOTAL	0.3				
Bond wire 1.4 %	Au	0.07	100 %	13592	7440-57-5
	TOTAL	0.07			
Total weight		5.2			

