

AFFECTED PART NUMBER(S)				
Manufacturer Part Number (MPN)	Description	Discontinued per PCN	Suggested Alternative Part Number(s)	Description of the Alternative Number
SMB_200_ATP	PLC Lens 3mm 0.171" Round Amber	NO	-	-
SMB_200_BTP	PLC Lens 3mm 0.171" Round Blue	NO	-	-
SMB_200_CTP	PLC Lens 3mm 0.171" Round Clear	NO	-	-
SMB_200_GTP	PLC Lens 3mm 0.171" Round Green	NO	-	-
SMB_200_RTP	PLC Lens 3mm 0.171" Round Red	NO	-	-
SMB_200_YTP	PLC Lens 3mm 0.171" Round Yellow	NO	-	-

Product Dimensions

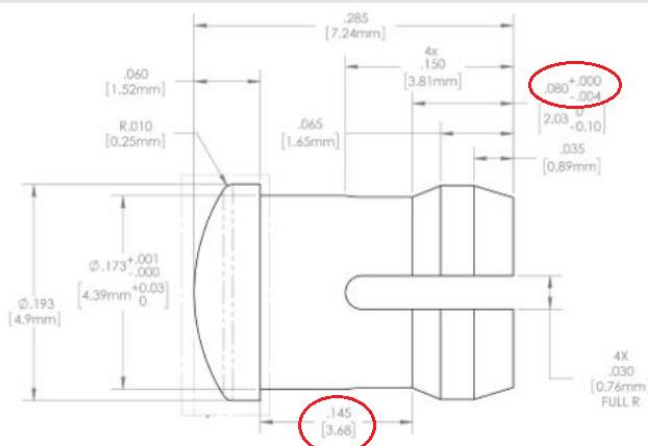

SMB 200 Series Round Low Profile Snap-in Fresnel Lens



Available in different transparent and translucent colors and snaps fit into a 0.171"(4.34mm) dia. panel hole.

Key Features

- **Mounting:** Mounts in a .171 .002 [4.34mm .05] panel hole on .250 [6.35mm] centers. Panel thickness .063 [1.6mm] to .125 [3.17mm]. Panel hole should be deburred, but not chamfered
- **Assembly:** Insert lens through panel hole, and insert LED into lens
- **Material:** Polycarbonate, UL 94-V2 GLO Series- Polycarbonate & Acrylic blend
- Lens style: Round with convex top
- Easy front panel snap-in
- Available in 7 different colors red, amber, green, blue, yellow, clear and white
- U.S. & Foreign Pat. Issued & Pending.

Ordering Data

ORDERING CODE: **SMB_200_XXX**

MATERIAL TABLE			
CODE	DESCRIPTION	PLASTIC	COLORANT/ PERCENTAGE
RTP	RED TRANSPARENT	PC - HF1130-112; UL RATING 94-V2	FCC-92808-PC-6; 4%
ATP	AMBER TRANSPARENT	PC - HF1130-112; UL RATING 94-V2	FCC-41686-PC-1; 4%
GTP	GREEN TRANSPARENT	PC - HF1130-112; UL RATING 94-V2	FCC-52676-PC-1; 4%
BTP	BLUE TRANSPARENT	PC - HF1130-112; UL RATING 94-V2	FCC-83191-PC-1; 4%
YTP	YELLOW TRANSPARENT	PC - HF1130-112; UL RATING 94-V2	FCC-41685-PC-1; 4%
CTP	CLEAR TRANSPARENT	PC - HF1130-112; UL RATING 94-V2	N/A (CLEAR)
GLO	WHITE TRANSLUCENT	PC/ACRYLIC BLEND - RTP 1800A S-24249	N/A (WHITE)

Product Dimensions

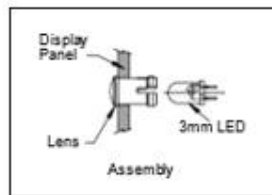
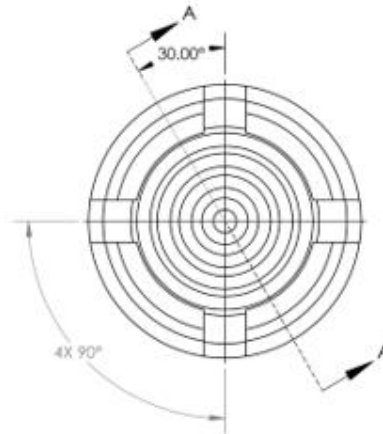
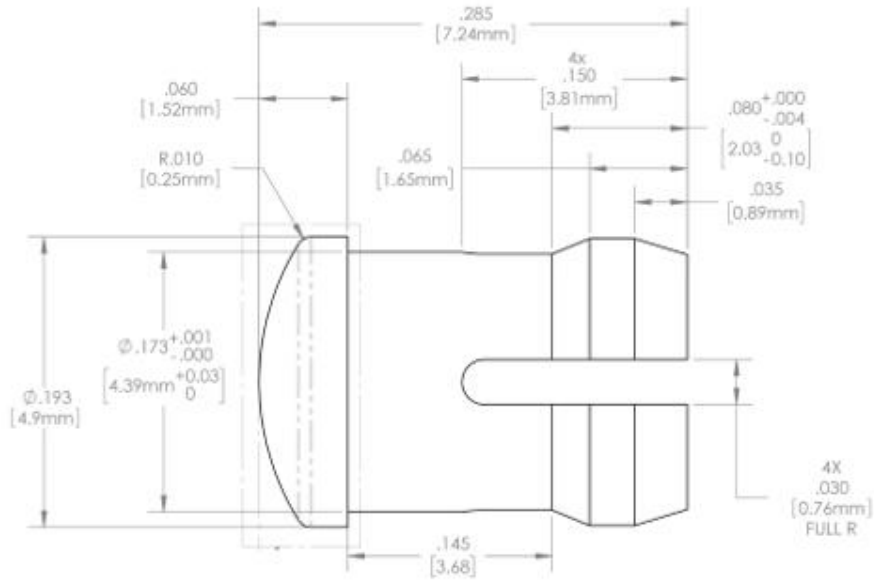

Notes:

All dimensions are in inches [mm]

Compliances and Approvals

