

Power Resistor Thick Film Technology



FEATURES

- 100 W at 25 °C case temperature heatsink mounted
- Direct mounting ceramic on heatsink
- Broad resistance range: 0.015 Ω to 1 MΩ
- Non inductive
- TO-247 package: compact and easy to mount
- **AEC-Q200 qualified**
- Material categorization: for definitions of compliance please see www.vishay.com/doc?99912

AUTOMOTIVE GRADE



RoHS
COMPLIANT

LINKS TO ADDITIONAL RESOURCES

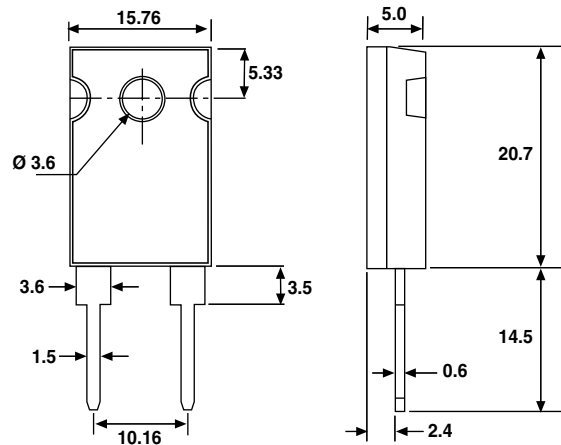

LTO series are the extension of RTO types. We used the direct ceramic mounting design (no metal tab) of our RCH power resistors applied to semiconductor packages.

DIMENSIONS in millimeters



Note

- Tolerances unless stated: ± 0.3 mm

STANDARD ELECTRICAL SPECIFICATIONS

MODEL	SIZE	RESISTANCE RANGE Ω	RATED POWER $P_{25\text{ °C}}$ W	LIMITING ELEMENT VOLTAGE U_L V	TOLERANCE ± %	TEMPERATURE COEFFICIENT ± ppm/°C	CRITICAL RESISTANCE Ω
LTO 100	TO-247	0.015 to 1M	100	500	1, 2, 5, 10	200, 350, 900	2.5 K

MECHANICAL SPECIFICATIONS

Mechanical Protection	Molded
Resistive Element	Thick film
Substrate	Alumina
Connections	Tinned copper
Weight	3.5 g max.
Mounting Torque	1 Nm

ENVIRONMENTAL SPECIFICATIONS

Temperature Range	-55 °C to +175 °C
Climatic Category	55 / 175 / 56
Flammability	IEC 60695-11-5 Application time: $t_a = 10$ s Burning duration: $t_b < 30$ s

TECHNICAL SPECIFICATIONS

Dissipation and Associated	Onto a heatsink
Power Rating and Thermal Resistance of the Component	100 W at +25 °C (case temp.) $R_{TH(j-c)}$: 1.5 °C/W Free air: 3.5 W at +25 °C
Temperature Coefficient	See Performance table ± 150 ppm/°C
Dielectric Strength MIL STD 202	3000 V_{RMS} - 1 min 10 mA max.
Insulation Resistance	≥ 10 ⁴ MΩ
Inductance	≤ 0.1 μH



PERFORMANCE		
TESTS	CONDITIONS	REQUIREMENTS
Momentary Overload	EN 60115-1 1.5 Pr/5 s $U_S < 1.5 U_L$	$\pm (0.5 \% + 0.005 \Omega)$
Load Life	EN 60115-1 1000 h Pr at +25 °C	$\pm (0.5 \% + 0.005 \Omega)$
High Temperature Exposure	AEC-Q200 rev. D conditions: MIL-STD-202 method 108 1000 h, +175 °C, unpowered	$\pm (0.25 \% + 0.005 \Omega)$
Temperature Cycling	AEC-Q200 rev. D conditions: JESD22 method JA-104 1000 cycles, -55 °C to +125 °C dwell time -15 min	$\pm (0.5 \% + 0.005 \Omega)$
Biased Humidity	AEC-Q200 rev. D conditions: MIL-STD-202 method 103 1000 h, 85 °C, 85 % RH	$\pm (1 \% + 0.005 \Omega)$
Operational Life	AEC-Q200 rev. D conditions: MIL-STD-202 method 108 2000 h, 90/30, powered, +125 °C	$\pm (0.5 \% + 0.005 \Omega)$
ESD Human Body Model	AEC-Q200 rev. D conditions: AEC-Q200-002 25 kV _{AD}	$\pm (0.5 \% + 0.005 \Omega)$
Vibration	AEC-Q200 rev. D conditions: MIL-STD-202 method 204 5 g's for 20 min, 12 cycles test from 10 Hz to 2000 Hz	$\pm (0.2 \% + 0.005 \Omega)$
Mechanical Shock	AEC-Q200 rev. D conditions: MIL-STD-202 method 213 100 g's, 6 ms, 3.75 m/s 3 shocks/direction	$\pm (0.2 \% + 0.005 \Omega)$
Terminal Strength	AEC-Q200 rev. D conditions: AEC-Q200-006 2 kgf, 60 s	$\pm (0.25 \% + 0.01 \Omega)$

SPECIAL FEATURES			
Resistance Values	≥ 0.015	≥ 0.1	> 20
Tolerances	$\pm 1 \%$ at $\pm 10 \%$		
Typical Temperature Coefficient (-55 °C to +175 °C)	± 900 ppm/°C	± 350 ppm/°C	± 200 ppm/°C

CHOICE OF THE HEATSINK

The user must choose according to the working conditions of the component (power, room temperature).

Maximum working temperature must not exceed 175 °C. The dissipated power is simply calculated by the following ratio:

$$P = \frac{\Delta T}{[R_{TH(j-c)}] + [R_{TH(c-h)}] + [R_{TH(h-a)}]} \quad (1)$$

P: Expressed in W

ΔT : Difference between maximum working temperature and room temperature

$R_{TH(j-c)}$: Thermal resistance value measured between resistive layer and outer side of the resistor. It is the thermal resistance of the component.

$R_{TH(c-h)}$: Thermal resistance value measured between outer side of the resistor and upper side of the heatsink. This is the thermal resistance of the interface (grease, thermal pad), and the quality of the fastening device.

$R_{TH(h-a)}$: Thermal resistance of the heatsink.

Example:

$R_{TH(c-h)} + R_{TH(h-a)}$ for LTO 100 power rating 10 W at ambient temperature +25 °C

Thermal resistance $R_{TH(j-c)}$: 1.5 °C/W

Considering equation (1) we have:

$$\Delta T = 175 \text{ °C} - 25 \text{ °C} = 150 \text{ °C}$$

$$R_{TH(j-c)} + R_{TH(c-h)} + R_{TH(h-a)} = \frac{\Delta T}{P} = \frac{150}{10} = 15 \text{ °C/W}$$

$$R_{TH(c-h)} + R_{TH(h-a)} = 15 \text{ °C/W} - 1.5 \text{ °C/W} = 13.5 \text{ °C/W}$$

with a thermal grease $R_{TH(c-h)} = 1 \text{ °C/W}$, we need a heatsink with $R_{TH(h-a)} = 12.5 \text{ °C/W}$.



POWER RATING

The temperature of the case should be maintained within the limits specified. To improve the thermal conductivity, surfaces in contact should be coated with a silicone grease and the torque applied on the screw for tightening should be around 1 Nm.

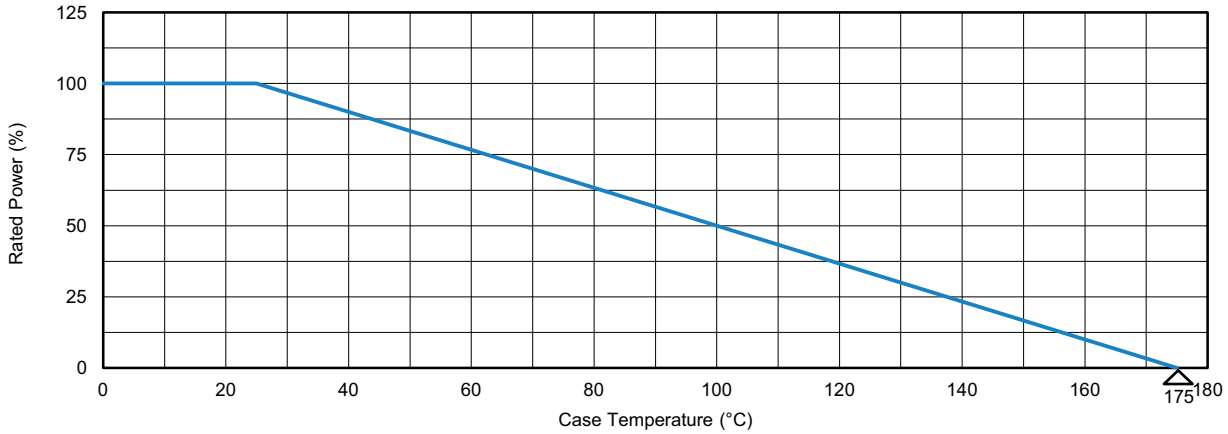

OVERLOADS

In any case the applied voltage must be lower than the maximum overload voltage of 750 V. The values indicated on the graph below are applicable to resistors in air or mounted onto a heatsink.

ENERGY CURVE

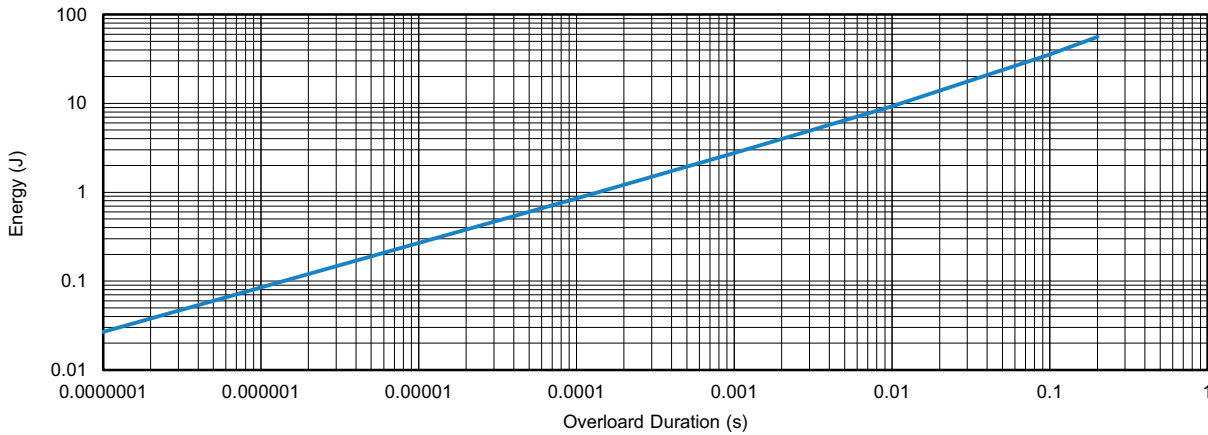

POWER CURVE

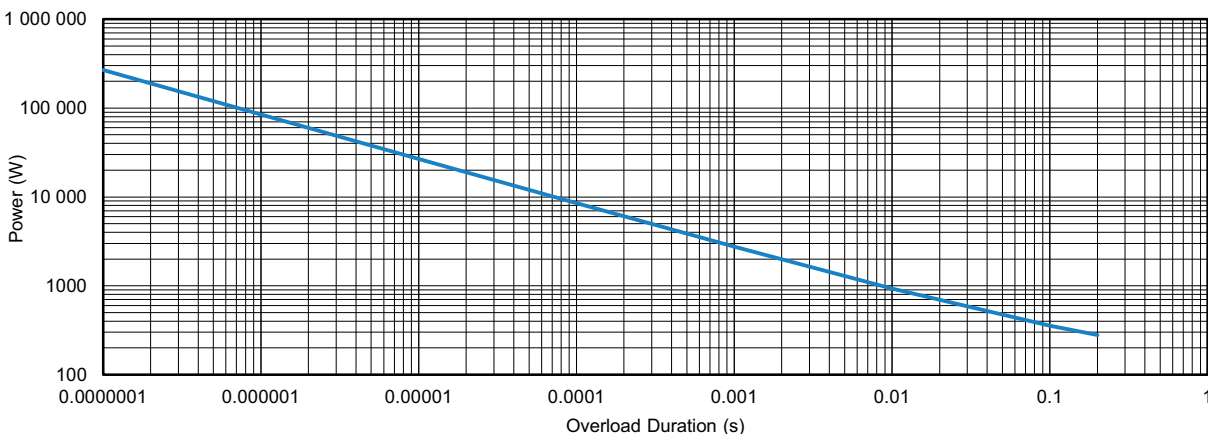



IMPEDANCE CURVE 10 Ω to 1 kΩ from 100 kHz to 300 MHz

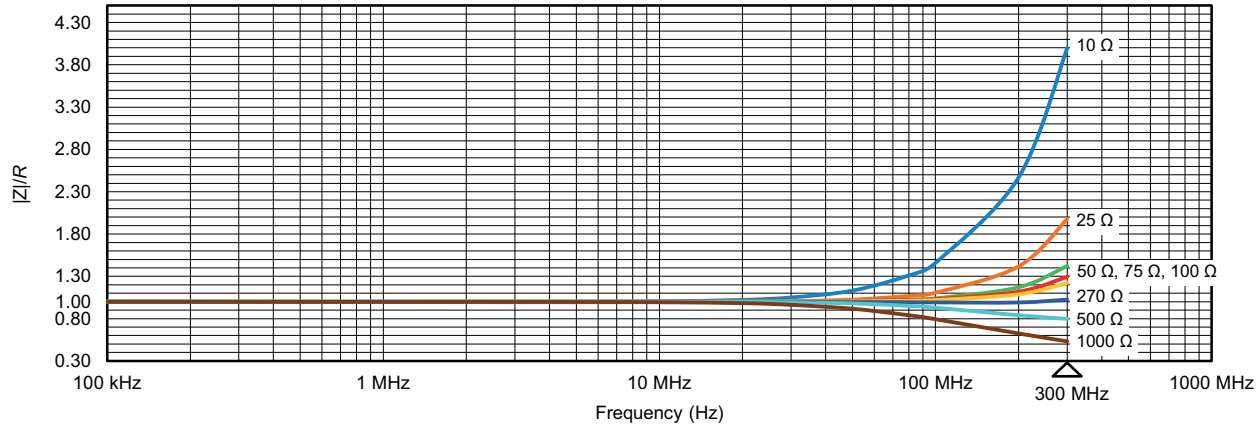

PACKAGING
Tube of 30 units

MARKING

Model, style, resistance value (in Ω), tolerance (in %), manufacturing date, Vishay Sfernice trademark.

ORDERING INFORMATION							
LTO	100	F	2.7 kΩ	± 1 %	xxx	TU30	e3
MODEL	STYLE	CONNECTIONS	RESISTANCE VALUE	TOLERANCE	CUSTOM DESIGN	PACKAGING	LEAD (Pb)-FREE
				± 1 %	Optional		
				± 2 %	on request:		
				± 5 %	special TCR,		
				± 10 %	shape etc.		

GLOBAL PART NUMBER INFORMATION															
L	T	O	1	0	0	F	2	7	0	0	0	J	T	E	3
GLOBAL MODEL	SIZE	LEADS	OHMIC VALUE				TOLERANCE	PACKAGING	LEAD (Pb)-FREE						
LTO	100	F = radial leads	The first four digits are significant figures and the last digit specifies the number of zeros to follow. R designates decimal point. 48R70 = 48.7 Ω 48701 = 48 700 Ω 10002 = 100 000 Ω R0100 = 0.01 Ω R4700 = 0.47 Ω 27000 = 2700 Ω = 2.7 kΩ				F = 1 % G = 2 % J = 5 % K = 10 %	T = tube Tube 30 pieces	E3 = pure tin						



Disclaimer

ALL PRODUCT, PRODUCT SPECIFICATIONS AND DATA ARE SUBJECT TO CHANGE WITHOUT NOTICE TO IMPROVE RELIABILITY, FUNCTION OR DESIGN OR OTHERWISE.

Vishay Intertechnology, Inc., its affiliates, agents, and employees, and all persons acting on its or their behalf (collectively, "Vishay"), disclaim any and all liability for any errors, inaccuracies or incompleteness contained in any datasheet or in any other disclosure relating to any product.

Vishay makes no warranty, representation or guarantee regarding the suitability of the products for any particular purpose or the continuing production of any product. To the maximum extent permitted by applicable law, Vishay disclaims (i) any and all liability arising out of the application or use of any product, (ii) any and all liability, including without limitation special, consequential or incidental damages, and (iii) any and all implied warranties, including warranties of fitness for particular purpose, non-infringement and merchantability.

Statements regarding the suitability of products for certain types of applications are based on Vishay's knowledge of typical requirements that are often placed on Vishay products in generic applications. Such statements are not binding statements about the suitability of products for a particular application. It is the customer's responsibility to validate that a particular product with the properties described in the product specification is suitable for use in a particular application. Parameters provided in datasheets and / or specifications may vary in different applications and performance may vary over time. All operating parameters, including typical parameters, must be validated for each customer application by the customer's technical experts. Product specifications do not expand or otherwise modify Vishay's terms and conditions of purchase, including but not limited to the warranty expressed therein.

Hyperlinks included in this datasheet may direct users to third-party websites. These links are provided as a convenience and for informational purposes only. Inclusion of these hyperlinks does not constitute an endorsement or an approval by Vishay of any of the products, services or opinions of the corporation, organization or individual associated with the third-party website. Vishay disclaims any and all liability and bears no responsibility for the accuracy, legality or content of the third-party website or for that of subsequent links.

Except as expressly indicated in writing, Vishay products are not designed for use in medical, life-saving, or life-sustaining applications or for any other application in which the failure of the Vishay product could result in personal injury or death. Customers using or selling Vishay products not expressly indicated for use in such applications do so at their own risk. Please contact authorized Vishay personnel to obtain written terms and conditions regarding products designed for such applications.

No license, express or implied, by estoppel or otherwise, to any intellectual property rights is granted by this document or by any conduct of Vishay. Product names and markings noted herein may be trademarks of their respective owners.