

THIS DRAWING IS UNPUBLISHED. RELEASED FOR PUBLICATION 27-02-02 .- .
 © COPYRIGHT 2002 By - ALL RIGHTS RESERVED.

LOC		DIST		REVISIONS			
GP	00	P	LTR	DESCRIPTION	DATE	DWN	APVD
		L		REVISED PER ECO-12-007484	25APR2012	CJV	CWR

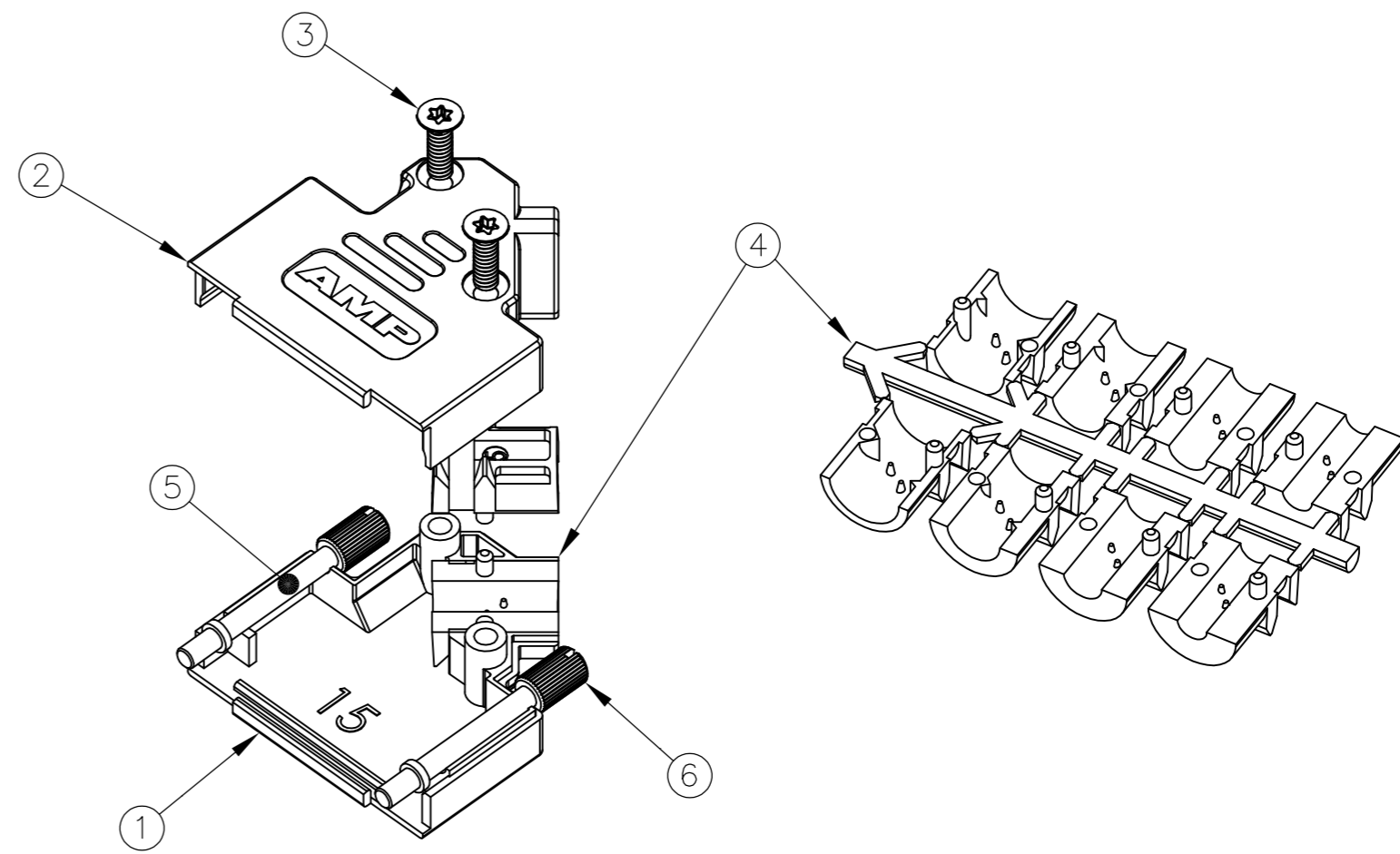
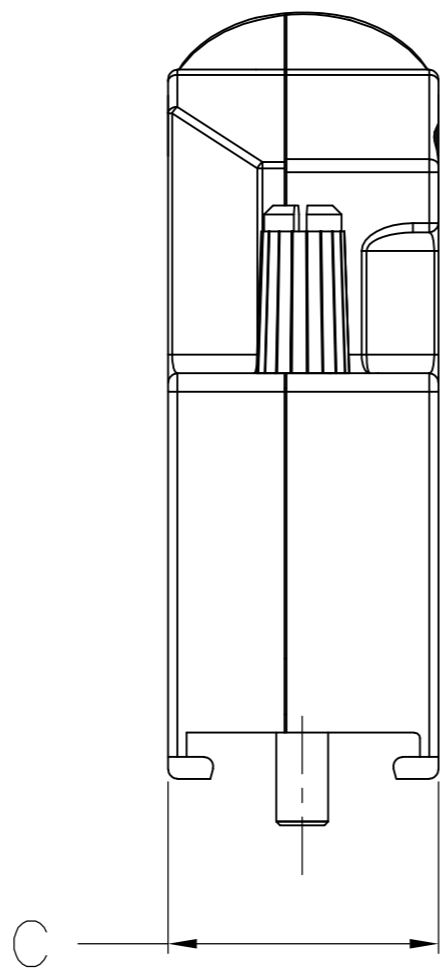
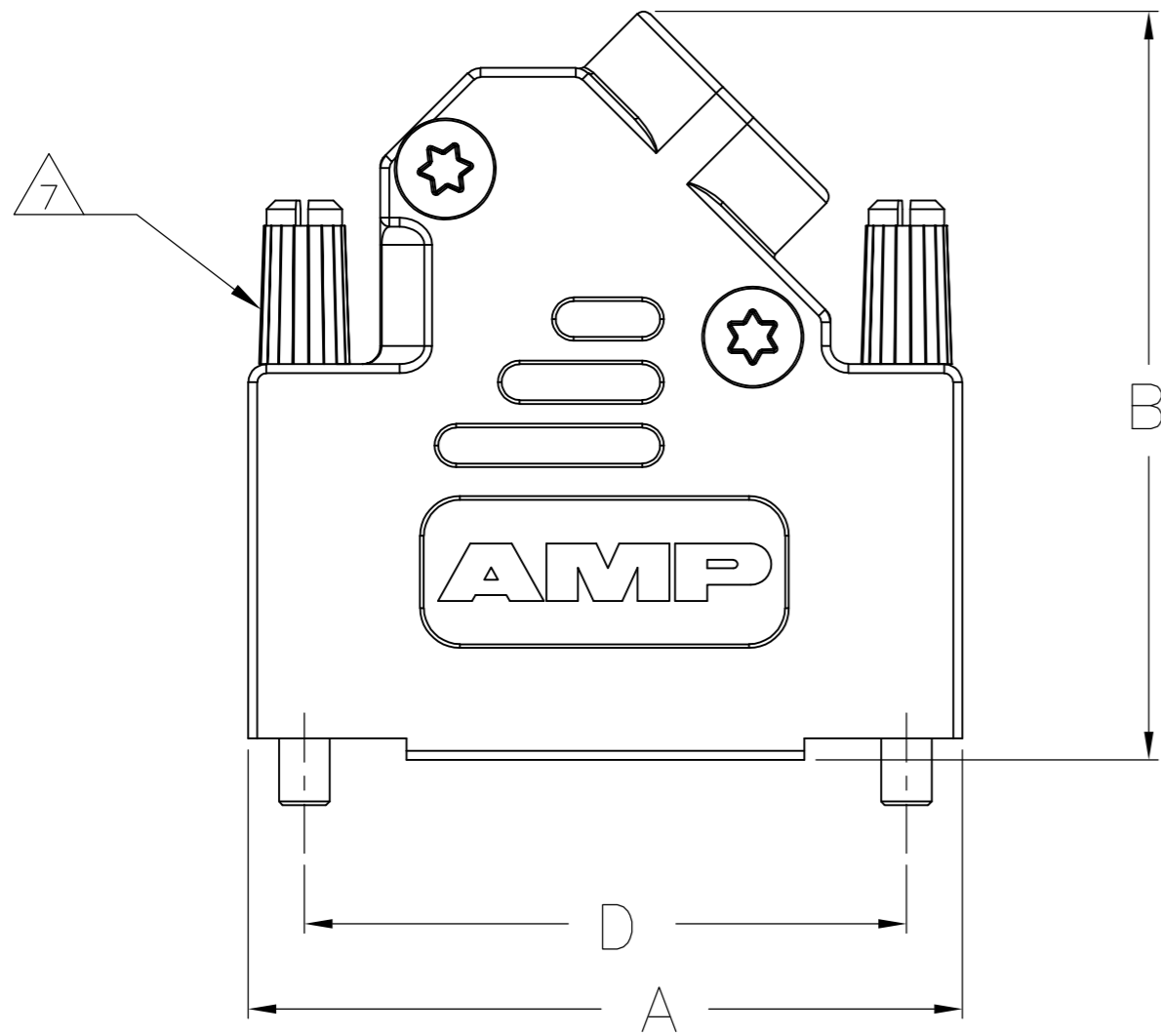

1. FOR ASSEMBLY DETAILS REFER TO LEAFLET 1478530-1.

2 BULK PACKAGED SHELL ASSEMBLIES. SHELL ASSEMBLY COMPONENTS PACKAGED SEPARATELY IN BAGS, 100 COMPONENTS PER BAG. ONE LEAFLET 1478530-1 PER PACK OF 100 PARTS.

3 INDIVIDUAL PACKAGED SHELL ASSEMBLIES. ONE BAG CONTAINS ALL COMPONENTS FOR ONE FULL ASSEMBLY AND ONE LEAFLET 1478530-1.

4 JACKSCREW QUANTITY:
 9 WAY ASSEMBLY: 1 JACKSCREW
 15 WAY ASSEMBLY: 2 JACKSCREWS
 25 WAY ASSEMBLY: 2 JACKSCREWS
 37 WAY ASSEMBLY: 2 JACKSCREWS

5. CABLE DIAMETER 4.0-13.0

6. OPTIONAL CABLE CRIMP KIT AVAILABLE FOR 6.0-9.5 DIAMETER CABLE. SEE 1478764

7 ONLY 1 JACKSCREW INCLUDED WITH 9 POSITION. FOR USE ON THIS SIDE.

8. 15 POSITION SHOWN.

3	63.5	14.6	40.2	69.7	TORX	4-40 UNC	4	37 WAY	5-1478763-4
3	47.0	14.6	40.2	53.2	TORX	4-40 UNC	3	25 WAY	5-1478763-3
3	33.3	14.6	40.2	39.5	TORX	4-40 UNC	2	15 WAY	5-1478763-2
3	25.0	14.6	36.2	31.0	TORX	4-40 UNC	1	9 WAY	5-1478763-1
2	47.0	14.6	40.2	53.2	TORX	M3	3	25 WAY	4-1478763-7
2	33.3	14.6	40.2	39.5	TORX	M3	2	15 WAY	4-1478763-6
2	25.0	14.6	36.2	31.0	TORX	M3	1	9 WAY	4-1478763-5
2	63.5	14.6	40.2	69.7	TORX	4-40 UNC	4	37 WAY	3-1478763-7
2	47.0	14.6	40.2	53.2	TORX	4-40 UNC	3	25 WAY	2-1478763-5
2	33.3	14.6	40.2	39.5	TORX	4-40 UNC	2	15 WAY	1-1478763-5
2	25.0	14.6	36.2	31.0	TORX	4-40 UNC	1	9 WAY	1478763-9
PACKAGING	D	C	B	A	SELF TAPPING FIXING SCREW TYPE	JACKSCREW THREAD	SHELL SIZE	POSITION	PART NUMBER

6	JACKSCREW KNOB	POLYAMIDE UL94 V2		2
5	JACKSCREW	CARBON STEEL	ZINC	4
4	STRAIN RELIEF	POLYCARBONATE UL94 V0		2
3	SELF TAPPING FIXING SCREW	CARBON STEEL	NICKEL	2
2	BACKSHELL TOP	ZINC DIE CAST	NICKEL	1
1	BACKSHELL BOTTOM	ZINC DIE CAST	NICKEL	1
ITEM	DESCRIPTION	MATERIAL	FINISH	QTY

THIS DRAWING IS A CONTROLLED DOCUMENT. DIMENSIONING AND TOLERANCING PER ASME Y14.5M-2009

DWN C. VALENTINE 06JAN2011
 CHK C. ROHDE 06JAN2012
 APVD C. ROHDE 06JAN2012
 PRODUCT SPEC
 APPLICATION SPEC

TE Connectivity
 ADK SERIES DIE-CAST BACKSHELL 45 DEGREE ENTRY

SIZE A2 CAGE CODE 00779 DRAWING NO C=1478763 RESTRICTED TO
 WEIGHT - SCALE 1:1 SHEET 1 OF 1 REV L
 CUSTOMER DRAWING

1478763

A