

SCREWLESS, SW,10P,5.08 PCB ✓ ACTIVE

Buchanan

TE Part # 1-1986712-0

TE Internal #: 1-1986712-0

[View on TE.com >](#)



Connectors > Terminal Blocks & Strips > PCB Terminal Blocks

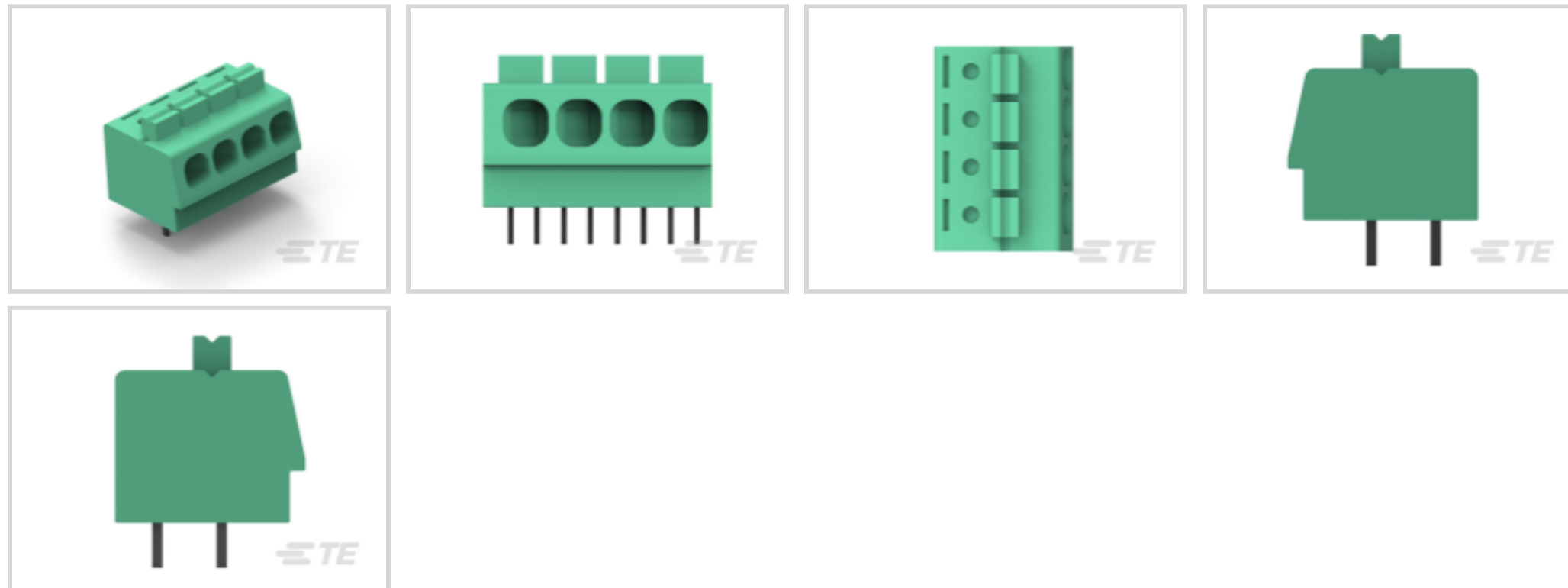

Connector Style: **Header**

Connector System: **Wire-to-Board**

Number of Positions: **10**

Centerline (Pitch): **5.08 mm [.2 in]**

Number of Rows: **2**

Features

Product Type Features

Wire Protection	With
Block Type	Spring Terminal Block
Header Type	Header Only
Connector Style	Header
Connector System	Wire-to-Board
Connector & Contact Terminates To	Printed Circuit Board

Configuration Features

Threaded Flange	Without
Number of Positions	10
Number of Rows	2
Wire Entry Angle	Side

Electrical Characteristics

Current Rating (Max)	16 A
Voltage	300 VAC

Body Features

Interlock	Without
Lever Color	White

Contact Features

Contact Mating Area Plating Material	Tin
Contact Mount	Through Hole
Pin Length	3.5 mm[.138 in]
Contact Base Material	Copper Alloy
Contact Current Rating (Max)	16 A

Mechanical Attachment

Screwless Terminal Block	Yes
Mounting Angle	Straight
Screw Flange	Without
Connector Mounting Type	Board Mount

Housing Features

Housing Color	Green
Housing Material	PA 66
Centerline (Pitch)	5.08 mm[.2 in]

Dimensions

PCB Tail Length	3.5 mm[.138 in]
Wire Size	.05 – 3 mm ²

Usage Conditions

Operating Temperature Range	-40 – 110 °C[-40 – 230 °F]
-----------------------------	----------------------------

Operation/Application

Circuit Application	Power & Signal
---------------------	----------------

Packaging Features

Packaging Quantity	100
--------------------	-----

Product Compliance

For compliance documentation, visit the product page on [TE.com](#)>

EU RoHS Directive 2011/65/EU	Not Yet Reviewed
EU ELV Directive 2000/53/EC	Not Yet Reviewed
China RoHS 2 Directive MIIT Order No 32, 2016	No Restricted Materials Above Threshold

EU REACH Regulation (EC) No. 1907/2006

Current ECHA Candidate List: JAN 2019 (197)

Candidate List Declared Against: JUN 2018 (191)

Halogen Content

Low Halogen - Br, Cl, F, I < 900 ppm per homogenous material. Also BFR/CFR/PVC Free

Solder Process Capability

Wave solder capable to 265°C

Product Compliance Disclaimer

This information is provided based on reasonable inquiry of our suppliers and represents our current actual knowledge based on the information they provided. This information is subject to change. The part numbers that TE has identified as EU RoHS compliant have a maximum concentration of 0.1% by weight in homogenous materials for lead, hexavalent chromium, mercury, PBB, PBDE, DBP, BBP, DEHP, DIBP, and 0.01% for cadmium, or qualify for an exemption to these limits as defined in the Annexes of Directive 2011/65/EU (RoHS2). Finished electrical and electronic equipment products will be CE marked as required by Directive 2011/65/EU. Components may not be CE marked. Additionally, the part numbers that TE has identified as EU ELV compliant have a maximum concentration of 0.1% by weight in homogenous materials for lead, hexavalent chromium, and mercury, and 0.01% for cadmium, or qualify for an exemption to these limits as defined in the Annexes of Directive 2000/53/EC (ELV). Regarding the REACH Regulations, TE's information on SVHC in articles for this part number is still based on the European Chemical Agency (ECHA) 'Guidance on requirements for substances in articles' (Version: 2, April 2011), applying the 0.1% weight on weight concentration threshold at the finished product level. TE is aware of the European Court of Justice ruling of September 10th, 2015 also known as O5A (Once An Article Always An Article) stating that, in case of 'complex object', the threshold for a SVHC must be applied to both the product as a whole and simultaneously to each of the articles forming part of its composition. TE has evaluated this ruling based on the new ECHA "Guidance on requirements for substances in articles" (June 2017, version 4.0) and will be updating its statements accordingly.

Customers Also Bought



TE Part #1986775-6
SCREWLESS, SW,6P,5.08
PCB, Low Amp



TE Part #1-1735446-1
2MM PITCH HPI POST
HEADER, VERTICAL, 11P



TE Part #1986712-5
SCREWLESS, SW,5P,5.08
PCB



TE Part #6-2176087-3
RP 1J 0.166W 309R 0.1%
25PPM 1K RL



TE Part #1986775-3
SCREWLESS, SW,3P,5.08
PCB, Low Amp

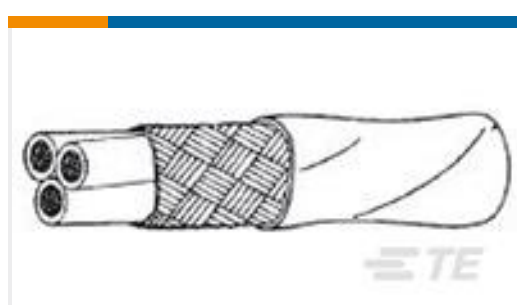

TE Part #633362-000
55PC1131-24-0/2/9-9

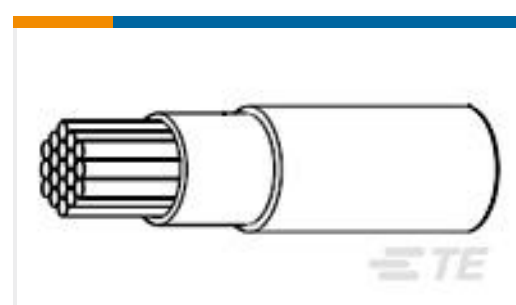

TE Part #609811-000
FLDWC0311-14-6



TE Part #2-1630186-0
HSA50 400R 5%



Documents

Product Drawings

SCREWLESS, SW,10P,5.08 PCB

English

Agency Approvals

VDE Certificate

English