



Product Change Notification

Current Date: 15-Oct-2021

TE Connectivity

Product Change Notification: P-21-021590

PCN Date: 13-OCT-21

Customer: TTI Electronics Asia Pte Ltd. (2771300)

Location: Singapore

Agreement: Agreement Unknown

TE would like to inform you of the following change(s) to the listed TE Connectivity Product. In case of any further questions about this change(s), please contact your TE Connectivity Sales Engineer. Affected part, drawing and/or specification numbers are listed on the attached sheet(s).

General Product Description:

WIRE SEAL, 2, 3 AND 6 CIRCUIT, UNIVERSAL MATE-N-LOK

Description of Changes

Manufacturing location change. Following Part Numbers will be transferred from Vendor Mexico to Vendor Dongguan, China.

Other attachments:

- [Customer Drawing](#)
- [Customer Drawing](#)
- [Customer Drawing](#)

Reason for Changes:

Dear Customer, as a result of our continuous strive for improving our processes, we hereby inform you about a transfer of tools and/or processes. The transfer is executed by following a strict transfer procedure, which guarantees no negative influence on quality, ability to supply and form-fit-function of the concerned products. The new manufacturing location is under a certified quality management system according the standard industry requirements. An internal release based on our specifications will be executed before any parts will be delivered, which guarantees the performance.

Estimated Dates:

Last Order Date (Obsolete Parts Only):	First Date To Ship (Changed Parts Only):
	13-OCT-2021
Last Ship Date (Obsolete Parts Only):	Last Date for Mixed Shipments: (Changed Parts Only):
	31-DEC-2021

Part Number(s) being Modified:

Part Number	Part Discontinued per PCN	Customer Drawing	Customer Part Number	Alias Part Number(s)	Substitute Part Number	Substitute Alias Part Number(s)	Description Of Difference
794270-1	NO			0-0794270-1, BACA-AMP-186			



Product Change Notification

Current Date: 15-Oct-2021

TE Connectivity

Product Change Notification: P-21-021590

PCN Date: 13-OCT-21

Customer: TTI Hong Kong Ltd (1407161)

Location: Hong Kong

Agreement: Agreement Unknown

TE would like to inform you of the following change(s) to the listed TE Connectivity Product. In case of any further questions about this change(s), please contact your TE Connectivity Sales Engineer. Affected part, drawing and/or specification numbers are listed on the attached sheet(s).

General Product Description:

WIRE SEAL, 2, 3 AND 6 CIRCUIT, UNIVERSAL MATE-N-LOK

Description of Changes

Manufacturing location change. Following Part Numbers will be transferred from Vendor Mexico to Vendor Dongguan, China.

Other attachments:

[Customer Drawing](#)

[Customer Drawing](#)

[Customer Drawing](#)

Reason for Changes:

Dear Customer, as a result of our continuous strive for improving our processes, we hereby inform you about a transfer of tools and/or processes. The transfer is executed by following a strict transfer procedure, which guarantees no negative influence on quality, ability to supply and form-fit-function of the concerned products. The new manufacturing location is under a certified quality management system according the standard industry requirements. An internal release based on our specifications will be executed before any parts will be delivered, which guarantees the performance.

Estimated Dates:

Last Order Date (Obsolete Parts Only):

First Date To Ship (Changed Parts Only):

13-OCT-2021

Last Ship Date (Obsolete Parts Only):

Last Date for Mixed Shipments: (Changed Parts Only):

31-DEC-2021

Part Number(s) being Modified:

Part Number	Part Discontinued per PCN	Customer Drawing	Customer Part Number	Alias Part Number(s)	Substitute Part Number	Substitute Alias Part Number(s)	Description Of Difference
794270-1	NO			0-0794270-1, BACA-AMP-186			

THIS DRAWING IS UNPUBLISHED. RELEASED FOR PUBLICATION
 © COPYRIGHT - By - ALL RIGHTS RESERVED.

LOC	DIST	REVISIONS			
P	LTR	DESCRIPTION	DATE	DWN	APVD
CM	53	A1	REVISED PER ECO-11-005027	11MAR11	RK HMR

- 1. MATERIAL: SELF LUBRICATING SILICON RUBBER
COLOR: BLUE
- 2. DIMENSIONS IN BRACKETS ARE IN INCHES.

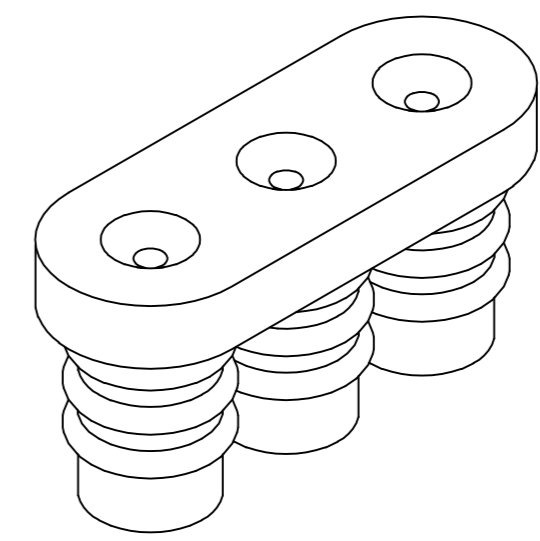
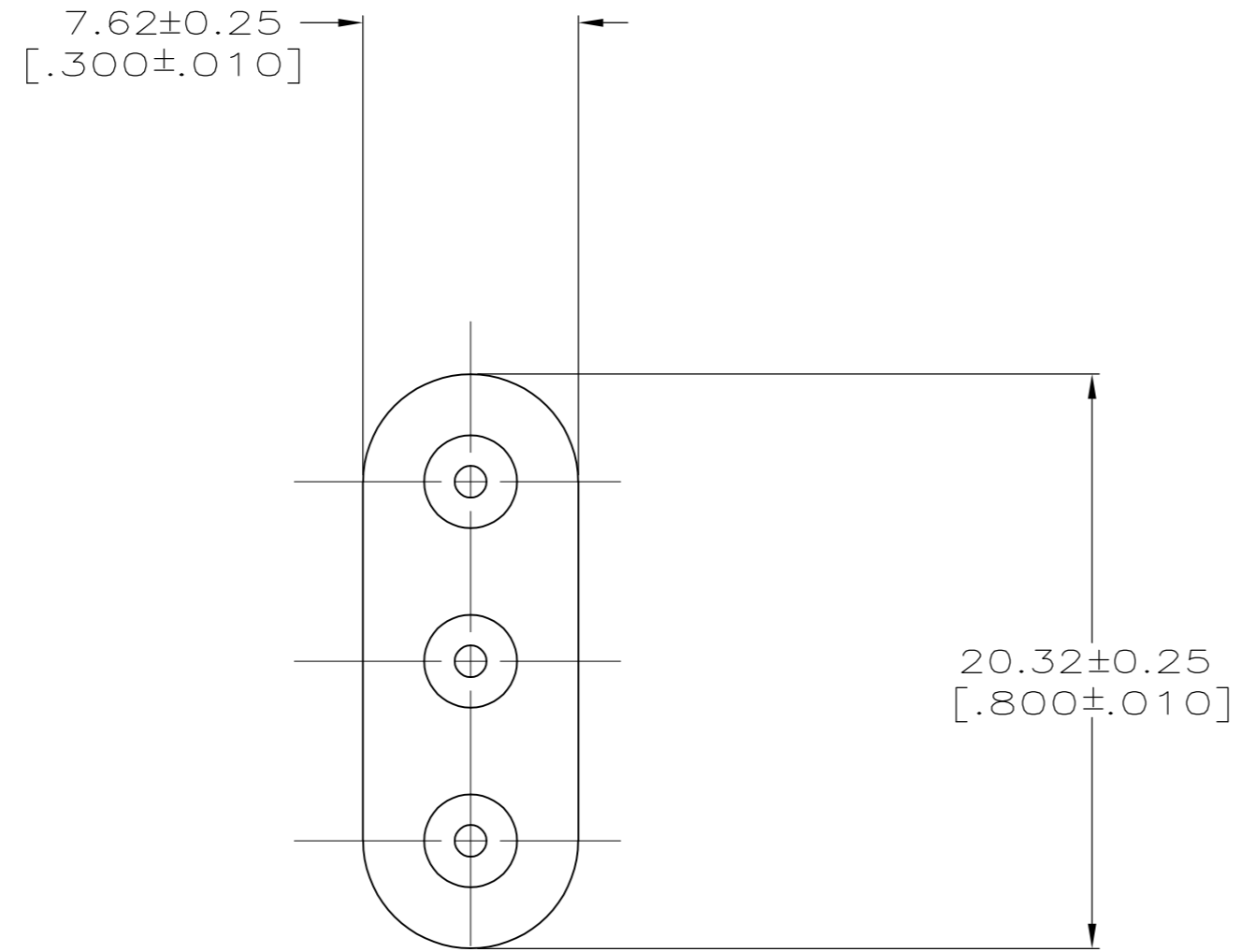

3-DIMENSIONAL MODEL
NTS

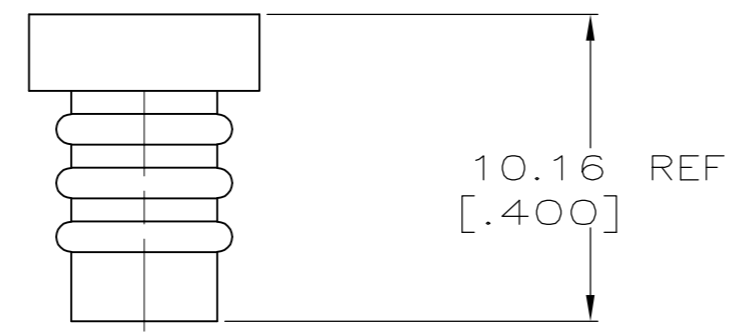

794272-1
PART NUMBER

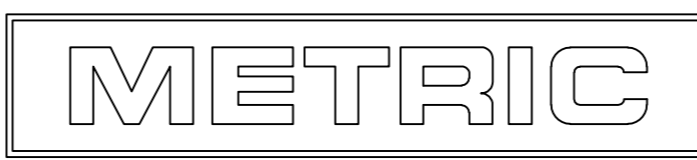

THIS DRAWING IS A CONTROLLED DOCUMENT.		DWN	B. LEWIS	3-25-97		TE Connectivity		
DIMENSIONS: INCHES		CHK	R. SWING	3-25-97		NAME		
		APVD	D. SELF	3-25-97		WIRE SEAL, 3 CIRCUIT, UNIVERSAL MATE-N-LOK™		
TOLERANCES UNLESS OTHERWISE SPECIFIED: 0 PLC ± - 1 PLC ± - 2 PLC ± - 3 PLC ± 0.13 [.005] 4 PLC ± - ANGLES ± 0° 30'		PRODUCT SPEC	-			SIZE	CAGE CODE	DRAWING NO
MATERIAL		FINISH	-		WEIGHT	-		RESTRICTED TO
-		-		-		A2	00779	C=794272
CUSTOMER DRAWING		SCALE		4:1	SHEET		1 of 1	REV
-		-		-		-		A1

THIS DRAWING IS UNPUBLISHED. RELEASED FOR PUBLICATION
 © COPYRIGHT - By - ALL RIGHTS RESERVED.

LOC	DIST	REVISIONS					
CM	53	P	LTR	DESCRIPTION	DATE	DWN	APVD
		A1		REVISED PER ECO-11-005027	11MAR11	RK	HMR

- 1. MATERIAL: SELF LUBRICATING SILICON RUBBER
COLOR: BLUE
- 2. DIMENSIONS IN BRACKETS ARE IN INCHES.

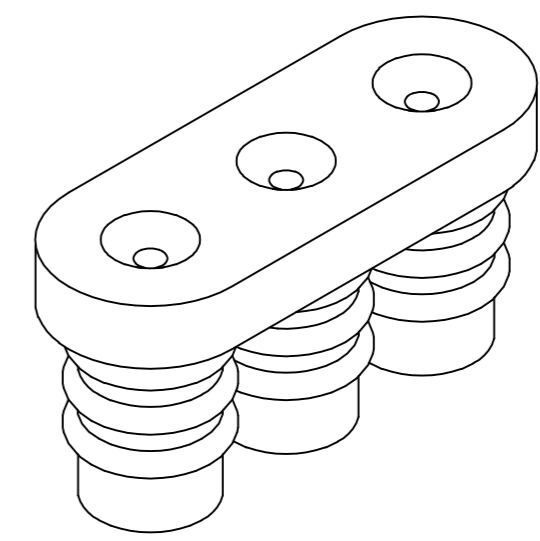
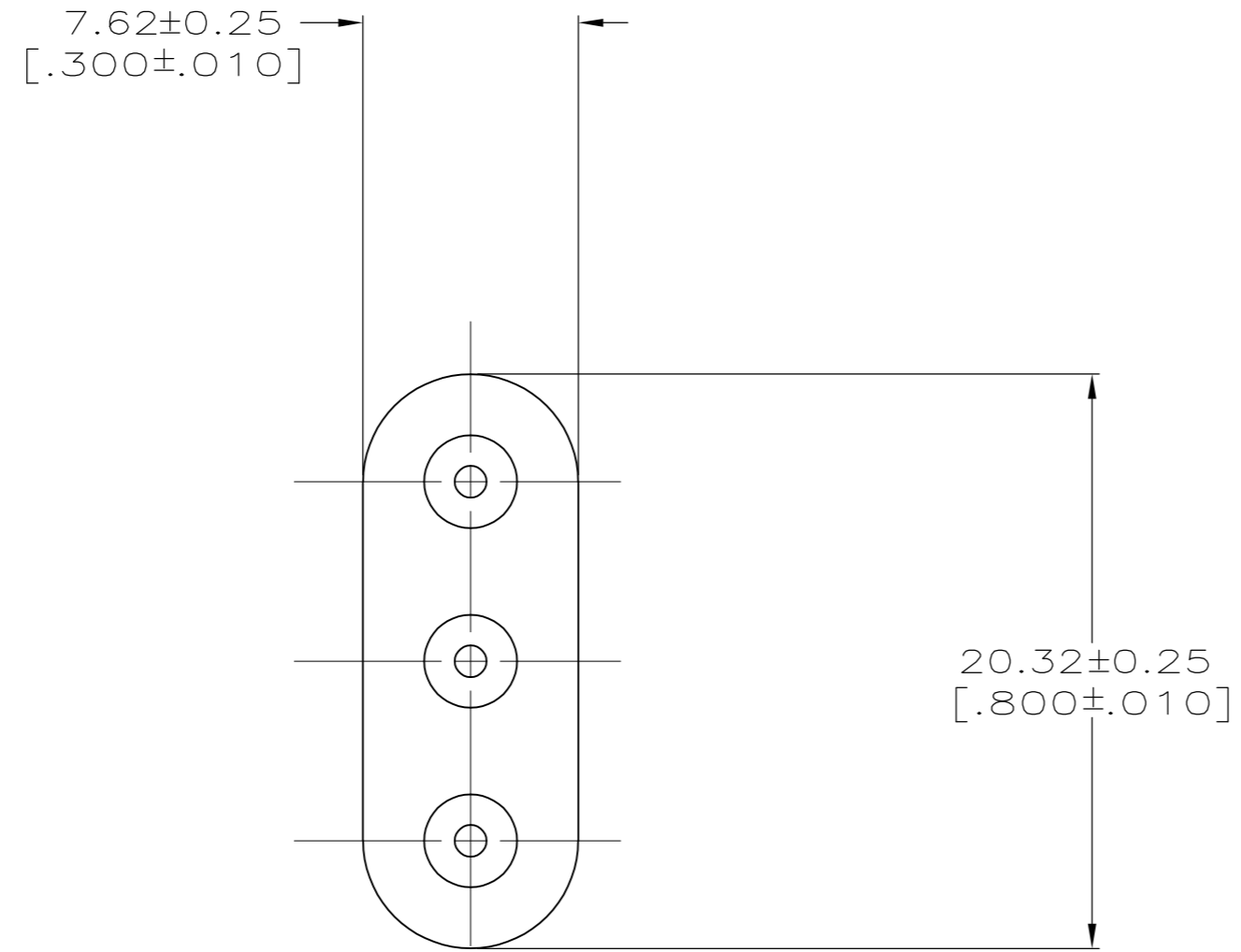

3-DIMENSIONAL MODEL
NTS

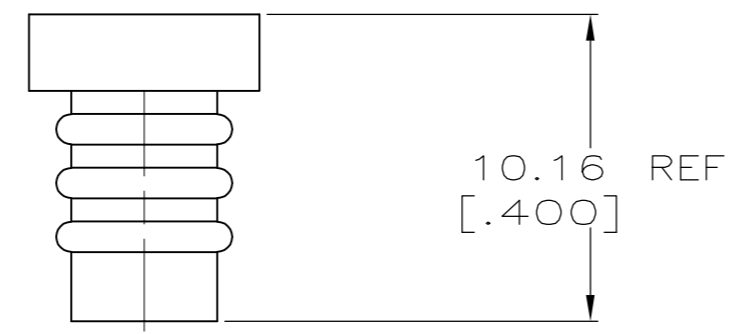

794272-1
PART NUMBER

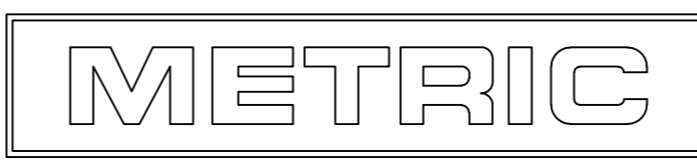

THIS DRAWING IS A CONTROLLED DOCUMENT.		DWN	B. LEWIS	3-25-97		TE Connectivity				
DIMENSIONS: INCHES		CHK	R. SWING	3-25-97		NAME				
		APVD	D. SELF	3-25-97		WIRE SEAL, 3 CIRCUIT, UNIVERSAL MATE-N-LOK™				
TOLERANCES UNLESS OTHERWISE SPECIFIED: 0 PLC ± - 1 PLC ± - 2 PLC ± - 3 PLC ± 0.13 [.005] 4 PLC ± - ANGLES ± 0° 30'		PRODUCT SPEC				SIZE	CAGE CODE	DRAWING NO	RESTRICTED TO	
MATERIAL		FINISH			WEIGHT	A2 00779 C-794272				
CUSTOMER DRAWING					SCALE	4:1	SHEET	1 OF 1	REV	A1

4

3

2

1

THIS DRAWING IS UNPUBLISHED. RELEASED FOR PUBLICATION .19
 (C) COPYRIGHT 19 BY AMP INCORPORATED. ALL RIGHTS RESERVED.

LOC		DIST		REVISIONS			
P	LTR	DESCRIPTION	DATE	DWN	APVD		
CM	53	A	REV PER EC 061B-0062-98	4-6-98	JH RS		

- 1. MATERIAL: SELF LUBRICATING SILICON RUBBER
COLOR: BLUE
- 2. DIMENSIONS IN BRACKETS ARE IN INCHES.

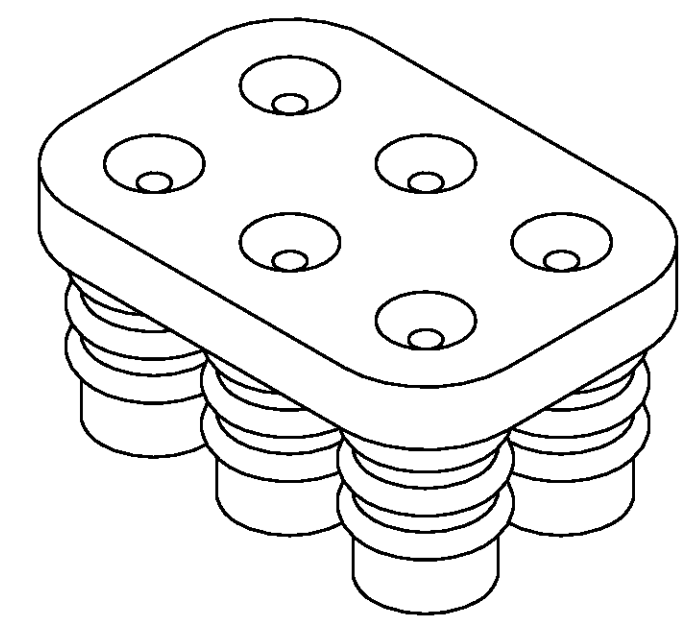
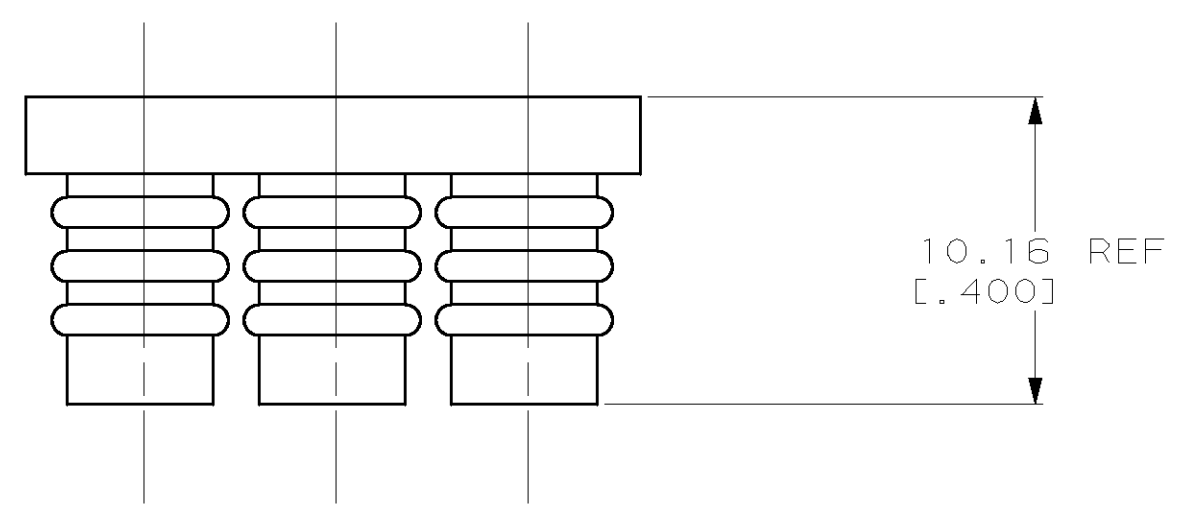
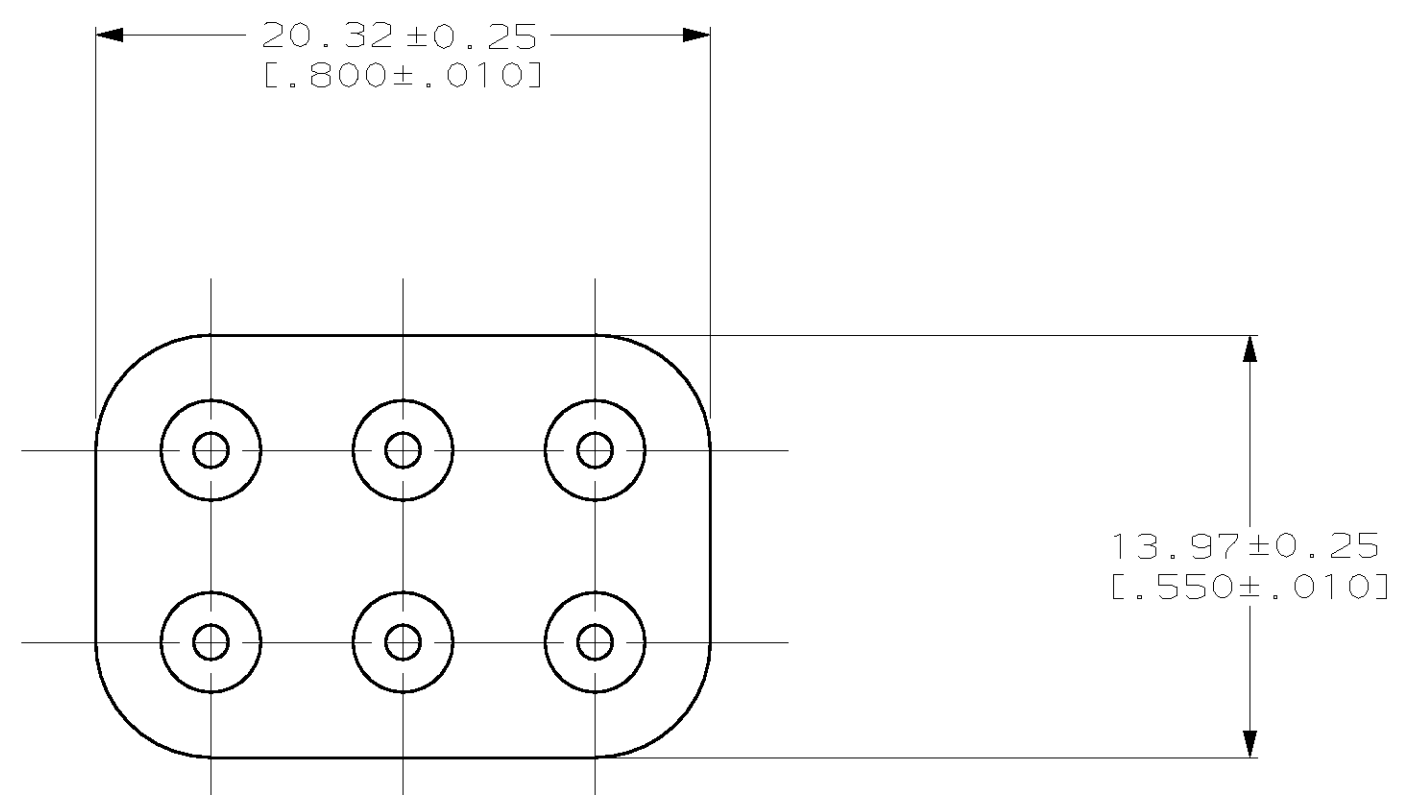

3-DIMENSIONAL MODEL NTS

794276-1
PART NUMBER

METRIC

THIS DRAWING IS A CONTROLLED DOCUMENT.		DWN B. LEWIS 3-25-97	AMP Incorporated Harrisburg, PA 17105-3608															
DIMENSIONS: INCHES		CHK R. SWING 3-25-97	NAME D. SELF 3-25-97															
<table border="1"> <thead> <tr> <th>TOLERANCES UNLESS OTHERWISE SPECIFIED:</th> <th></th> </tr> </thead> <tbody> <tr><td>0 PLC</td><td>±</td></tr> <tr><td>1 PLC</td><td>±</td></tr> <tr><td>2 PLC</td><td>±</td></tr> <tr><td>3 PLC</td><td>±0.13 [1.005]</td></tr> <tr><td>4 PLC</td><td>±</td></tr> <tr><td>ANGLES</td><td>±0°30'</td></tr> </tbody> </table>		TOLERANCES UNLESS OTHERWISE SPECIFIED:		0 PLC	±	1 PLC	±	2 PLC	±	3 PLC	±0.13 [1.005]	4 PLC	±	ANGLES	±0°30'	PRODUCT SPEC -	WIRE SEAL, 6 CIRCUIT, UNIVERSAL MATE-N-LOK™	
TOLERANCES UNLESS OTHERWISE SPECIFIED:																		
0 PLC	±																	
1 PLC	±																	
2 PLC	±																	
3 PLC	±0.13 [1.005]																	
4 PLC	±																	
ANGLES	±0°30'																	
MATERIAL △		FINISH -	APVD D. SELF 3-25-97	RESTRICTED TO -														
CUSTOMER DRAWING		SCALE 4:1	SIZE A2	CAGE CODE 00779														
		DRAWING NO. C-794276	DRAWING NO. 794276															
		SHEET 1	OF 1															
		REV A																

794276