



Product Change Notification

Current Date: 24-Mar-2020

TE Connectivity

Product Change Notification: E-20-003530

PCN Date: 18-MAR-20

Customer: TTI Inc(0000139702)

Location: WORLDWIDE

Agreement: Agreement Unknown

TE would like to inform you of the following change(s) to the listed TE Connectivity Product. In case of any further questions about this change(s), please contact your TE Connectivity Sales Engineer. Affected part, drawing and/or specification numbers are listed on the attached sheet(s).

General Product Description:

AMPSEAL Sealed Connector System - Header Assembly

Description of Changes

The Industrial and Commercial Transportation business unit of TE Connectivity is making a change to the AMPSEAL Header Assembly Customer Drawing notes and dimensions for the part number(s) listed below. These PNs are TE proprietary designs, therefore considered catalog/general market product. The change does not affect Form Fit or Function of the AMPSEAL Headers. This change is for notification purposes only and no PPAP is planned or required.

Other attachments:

[Modified header customer dwg](#)

Reason for Changes:

Customer Request. Dear Customer, we hereby inform you of this change. The change is necessary to clarify the information on mounting screw used on the AMPSEAL Header, to modify the mounting hole location dimensions from reference dimension to a tolerance dimension and the suggested mounting hole dimensions will be expanded to aid in the assembly of the header. The change does not impact performance. IMPORTANT: The current and previous revisions of these parts can be used interchangeably in the field.

Estimated Dates:

Last Order Date (Obsolete Parts Only):

First Date To Ship (Changed Parts Only):

Last Ship Date (Obsolete Parts Only):

Last Date for Mixed Shipments: (Changed Parts Only):

No Mixed Shipments

The documents listed below are being modified. Related parts that are not explicitly listed on this PCN are not being modified or discontinued as per the PCN. The Last Order Date, Last Ship Date, First Date to Ship Changed Parts and last date for Mixed Shipments apply only to parts explicitly listed on this PCN.

Note: This PCN contains only document changes, these changes do not affect the form, fit or function of the parts referenced.

Customer Drawing(s) Being Modified:

Drawing Number	Related Part Number	Customer Part Number	Current Revision	New Revision
770669	770669-1		K12	
776087	1-776087-1, 776087-1	4268659	E12	
776163	776163-1, 1-776163-1	TYC1-776163-1	J9	
776200	776200-1		D14	
776228	1-776228-1, 1-776228-4, 776228-2		C14	
776231	1-776231-1	TYC1-776231-1	A14	
776262	776262-1, 776262-2, 1-776262-1	TYC776262-1	A9	
776267	1-776267-1	TYC1-776267-1	B8	
776276	776276-1, 1-776276-1		B10	
776280	776280-6, 776280-1, 1-776280-1	TYC776280-1	F9	

Customer: TTI, Inc. (1305175)

Location: Maisach-gernlinden

Agreement Number: TTI001

The documents listed below are being modified. Related parts that are not explicitly listed on this PCN are not being modified or discontinued as per the PCN. The Last Order Date, Last Ship Date, First Date to Ship Changed Parts and last date for Mixed Shipments apply only to parts explicitly listed on this PCN.

Customer Drawing(s) Being Modified:

Drawing Number	Related Part Number	Customer Part Number	Current Revision	New Revision
776087	1-776087-1	4268659, TYC1-776087-1	E12	
776163	1-776163-1	TYC1-776163-1	J9	
776228	1-776228-4		C14	
776231	1-776231-1	TYC1-776231-1	A14	
776262	776262-1	TYC776262-1	A9	
776267	1-776267-1	TYC1-776267-1	B8	

Drawing Number	Related Part Number	Customer Part Number	Current Revision	New Revision
776276	1-776276-1		B10	
776280	776280-1	TYC776280-1	F9	

Customer: TTI Inc (3164508)

Location: Fort Worth

Agreement Number: Agreement Unknown

The documents listed below are being modified. Related parts that are not explicitly listed on this PCN are not being modified or discontinued as per the PCN. The Last Order Date, Last Ship Date, First Date to Ship Changed Parts and last date for Mixed Shipments apply only to parts explicitly listed on this PCN.

Customer Drawing(s) Being Modified:

Drawing Number	Related Part Number	Customer Part Number	Current Revision	New Revision
770669	770669-1		K12	
776087	1-776087-1		E12	
776163	1-776163-1		J9	
776200	776200-1		D14	
776228	1-776228-1		C14	
776231	1-776231-1		A14	
776262	1-776262-1		A9	
776267	1-776267-1		B8	
776276	1-776276-1		B10	
776280	1-776280-1		F9	

Customer: TTI Inc (3165294)

Location: Independence

Agreement Number: Agreement Unknown

The documents listed below are being modified. Related parts that are not explicitly listed on this PCN are not being modified or discontinued as per the PCN. The Last Order Date, Last Ship Date, First Date to Ship Changed Parts and last date for Mixed Shipments apply only to parts explicitly listed on this PCN.

Customer Drawing(s) Being Modified:

Drawing Number	Related Part Number	Customer Part Number	Current Revision	New Revision
776276	776276-1		B10	

Customer: TTI Inc (1281288)

Location: Fort Worth

Agreement Number: TTI002

The documents listed below are being modified. Related parts that are not explicitly listed on this PCN are not being modified or discontinued as per the PCN. The Last Order Date, Last Ship Date, First Date to Ship Changed Parts and last date for Mixed Shipments apply only to parts explicitly listed on this PCN.

Customer Drawing(s) Being Modified:

Drawing Number	Related Part Number	Customer Part Number	Current Revision	New Revision
770669	770669-1		K12	
776087	1-776087-1	4268659	E12	
776163	1-776163-1		J9	
776200	776200-1		D14	
776228	1-776228-1		C14	
776231	1-776231-1		A14	
776262	1-776262-1		A9	
776267	1-776267-1		B8	
776276	1-776276-1		B10	
776280	776280-1		F9	

Customer: Shanghai TTI Electronics Co Ltd (1405773)

Location: Shanghai

Agreement Number: Agreement Unknown

The documents listed below are being modified. Related parts that are not explicitly listed on this PCN are not being modified or discontinued as per the PCN. The Last Order Date, Last Ship Date, First Date to Ship Changed Parts and last date for Mixed Shipments apply only to parts explicitly listed on this PCN.

Customer Drawing(s) Being Modified:

Drawing Number	Related Part Number	Customer Part Number	Current Revision	New Revision
776087	776087-1		E12	
776163	776163-1		J9	
776228	1-776228-1		C14	
776280	776280-1		F9	

Customer: TTI Electronics Asia Pte Ltd (3063486)

Location: Taipei

Agreement Number: Agreement Unknown

The documents listed below are being modified. Related parts that are not explicitly listed on this PCN are not being modified or discontinued as per the PCN. The Last Order Date, Last Ship Date, First Date to Ship Changed Parts and last date for Mixed Shipments apply only to parts explicitly listed on this PCN.

Customer Drawing(s) Being Modified:

Drawing Number	Related Part Number	Customer Part Number	Current Revision	New Revision
776280	776280-1		F9	

Customer: TTI Inc (2752328)

Location: Fremont

Agreement Number: Agreement Unknown

The documents listed below are being modified. Related parts that are not explicitly listed on this PCN are not being modified or discontinued as per the PCN. The Last Order Date, Last Ship Date, First Date to Ship Changed Parts and last date for Mixed Shipments apply only to parts explicitly listed on this PCN.

Customer Drawing(s) Being Modified:

Drawing Number	Related Part Number	Customer Part Number	Current Revision	New Revision
776262	776262-2		A9	

Customer: TTI Inc (168830)

Location: Fort Worth

Agreement Number: Agreement Unknown

The documents listed below are being modified. Related parts that are not explicitly listed on this PCN are not being modified or discontinued as per the PCN. The Last Order Date, Last Ship Date, First Date to Ship Changed Parts and last date for Mixed Shipments apply only to parts explicitly listed on this PCN.

Customer Drawing(s) Being Modified:

Drawing Number	Related Part Number	Customer Part Number	Current Revision	New Revision
776163	776163-1		J9	

Customer: TTI (3075935)

Location: Eden Prairie

Agreement Number: Agreement Unknown

The documents listed below are being modified. Related parts that are not explicitly listed on this PCN are not being modified or discontinued as per the PCN. The Last Order Date, Last Ship Date, First Date to Ship Changed Parts and last date for Mixed Shipments apply only to parts explicitly listed on this PCN.

Customer Drawing(s) Being Modified:

Drawing Number	Related Part Number	Customer Part Number	Current Revision	New Revision
776280	1-776280-1		F9	

Customer: TTI Inc (3221065)

Location: Fort Worth

Agreement Number: Agreement Unknown

The documents listed below are being modified. Related parts that are not explicitly listed on this PCN are not being modified or discontinued as per the PCN. The Last Order Date, Last Ship Date, First Date to Ship Changed Parts and last date for Mixed Shipments apply only to parts explicitly listed on this PCN.

Customer Drawing(s) Being Modified:

Drawing Number	Related Part Number	Customer Part Number	Current Revision	New Revision
776163	1-776163-1		J9	

Customer: TTI Electronics Asia Pte Ltd. (2771300)

Location: Singapore

Agreement Number: Agreement Unknown

The documents listed below are being modified. Related parts that are not explicitly listed on this PCN are not being modified or discontinued as per the PCN. The Last Order Date, Last Ship Date, First Date to Ship Changed Parts and last date for Mixed Shipments apply only to parts explicitly listed on this PCN.

Customer Drawing(s) Being Modified:

Drawing Number	Related Part Number	Customer Part Number	Current Revision	New Revision
776228	776228-2		C14	
776280	776280-6		F9	

REVISIONS				
P.	LTN	DESCRIPTION	DATE	APVD
	K12	REVISED PER ECO-19-009419	20JUN2019	DS DS

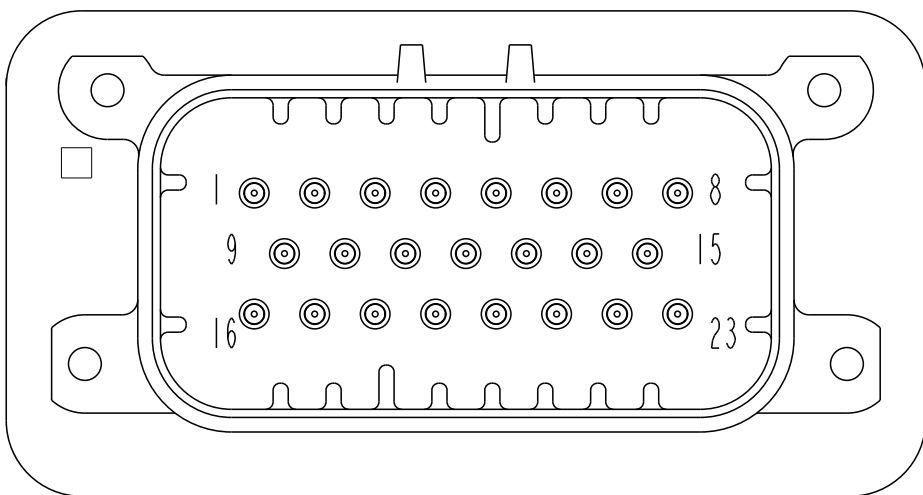

770669-2 & 1-770669-2
 KEY LOCATION
 SCALE 2:1

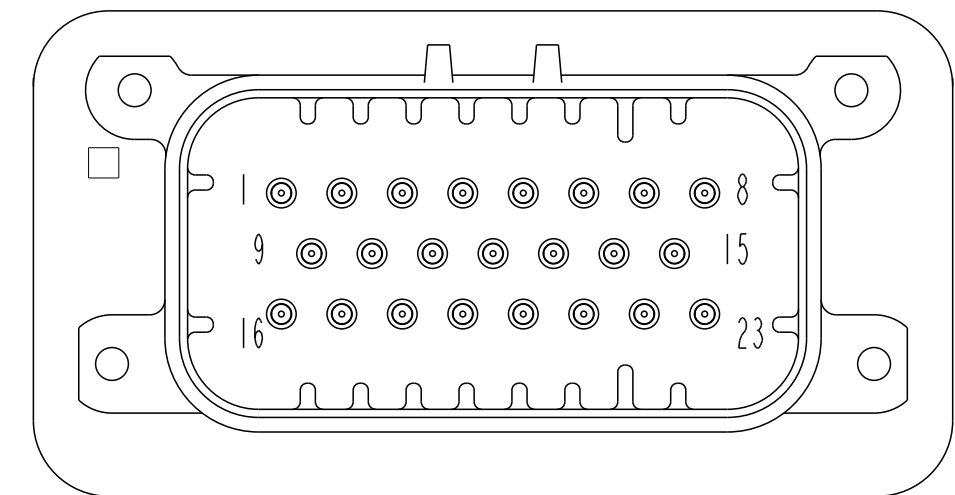

770669-4 & 1-770669-4
 KEY LOCATION
 SCALE 2:1

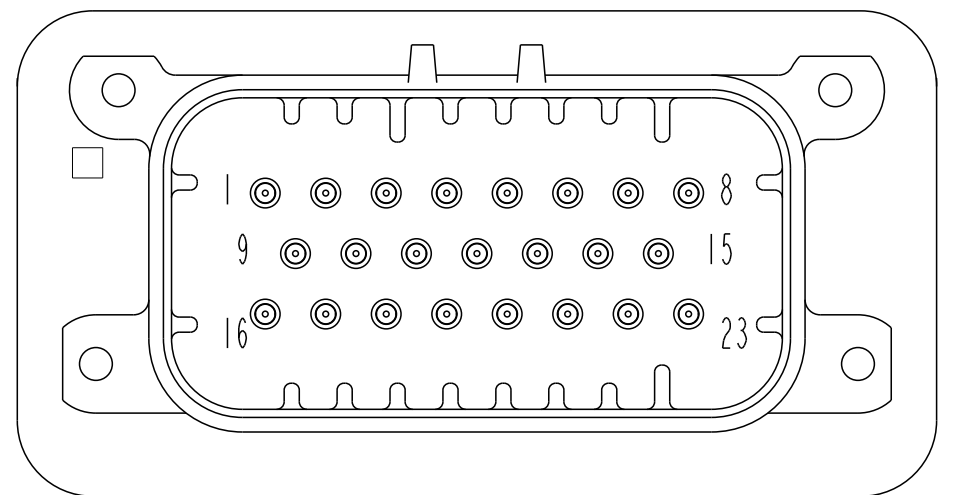

770669-5 & 1-770669-5
 KEY LOCATION
 SCALE 2:1

- 1. SUGGESTED MOUNTING SCREW SIZE IS $\varnothing 2.50-3.00\text{mm}$ [$\varnothing 0.099 - 0.118$ INCH] SELF TAPPING THREAD FORMING SCREW, SUCH AS DELTA PT, TO BE DRIVEN AT 0.6-0.8 N-m. THE CUSTOMER SHOULD TEST THE SCREW SIZE AND TYPE IN ORDER TO VERIFY THEIR SELECTION FOR THEIR APPLICATION
- 2. DATE CODE TO BE BRANDED IN THIS LOCATION PER TE SPEC 102-60. USE 5 DIGIT CODE: FIRST 2 DIGITS = YEAR, SECOND 2 DIGITS = WEEK, LAST DIGIT = DAY
- 3. HOUSING COLORS ARE MECHANICALLY KEyed TO MATE ONLY WITH IDENTICALLY COLORED PLUG ASSEMBLIES
- 4. MATERIALS: HEADER HOUSING - GLASS FILLED PBT
 PINS: TIN OR GOLD PLATED BRASS
- 5. HEADER MATES TO PLUG ASSEMBLY 770680 WHICH USES REELED TERMINALS 770520 OR LOOSE PIECE TERMINALS 770854

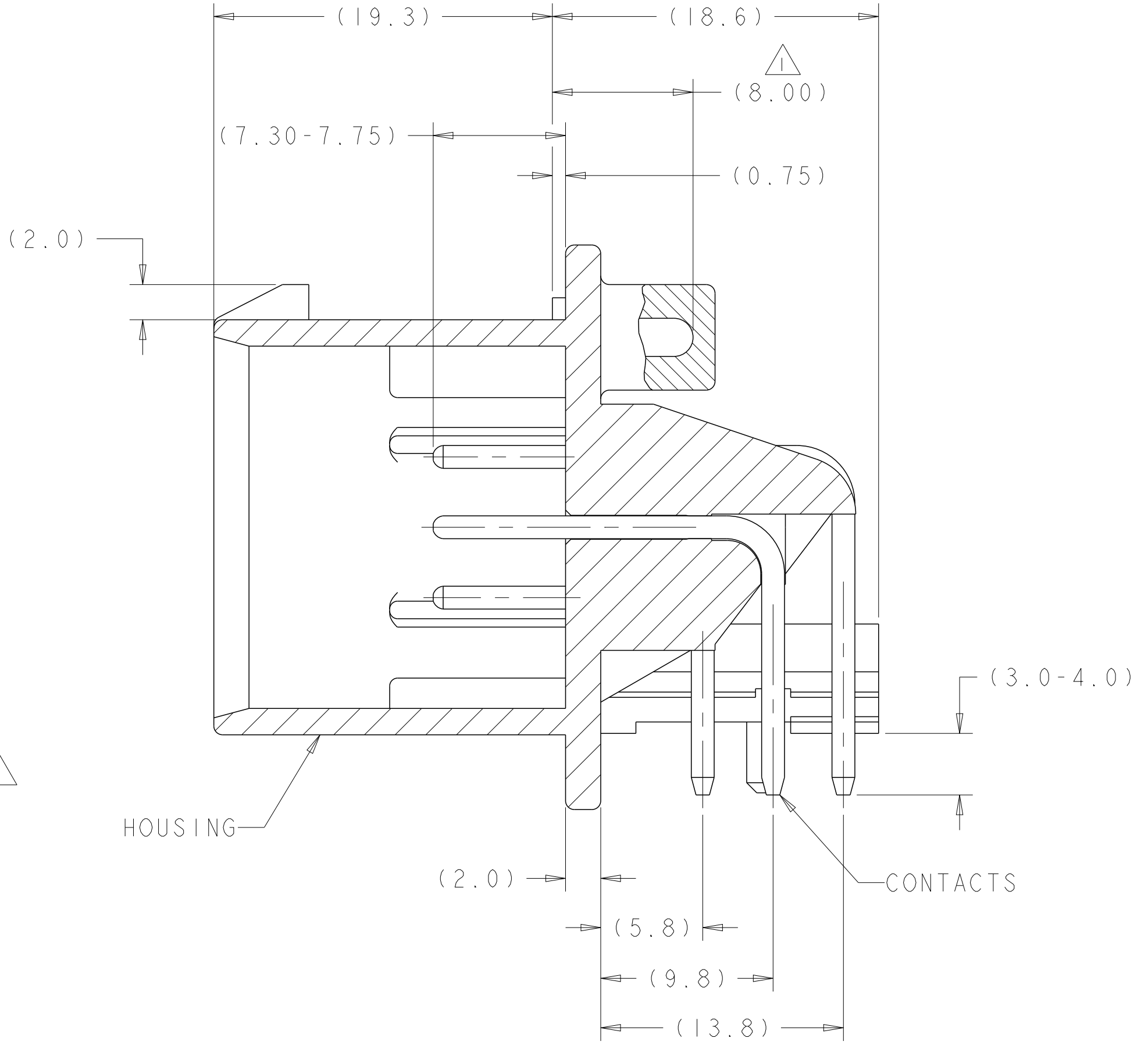
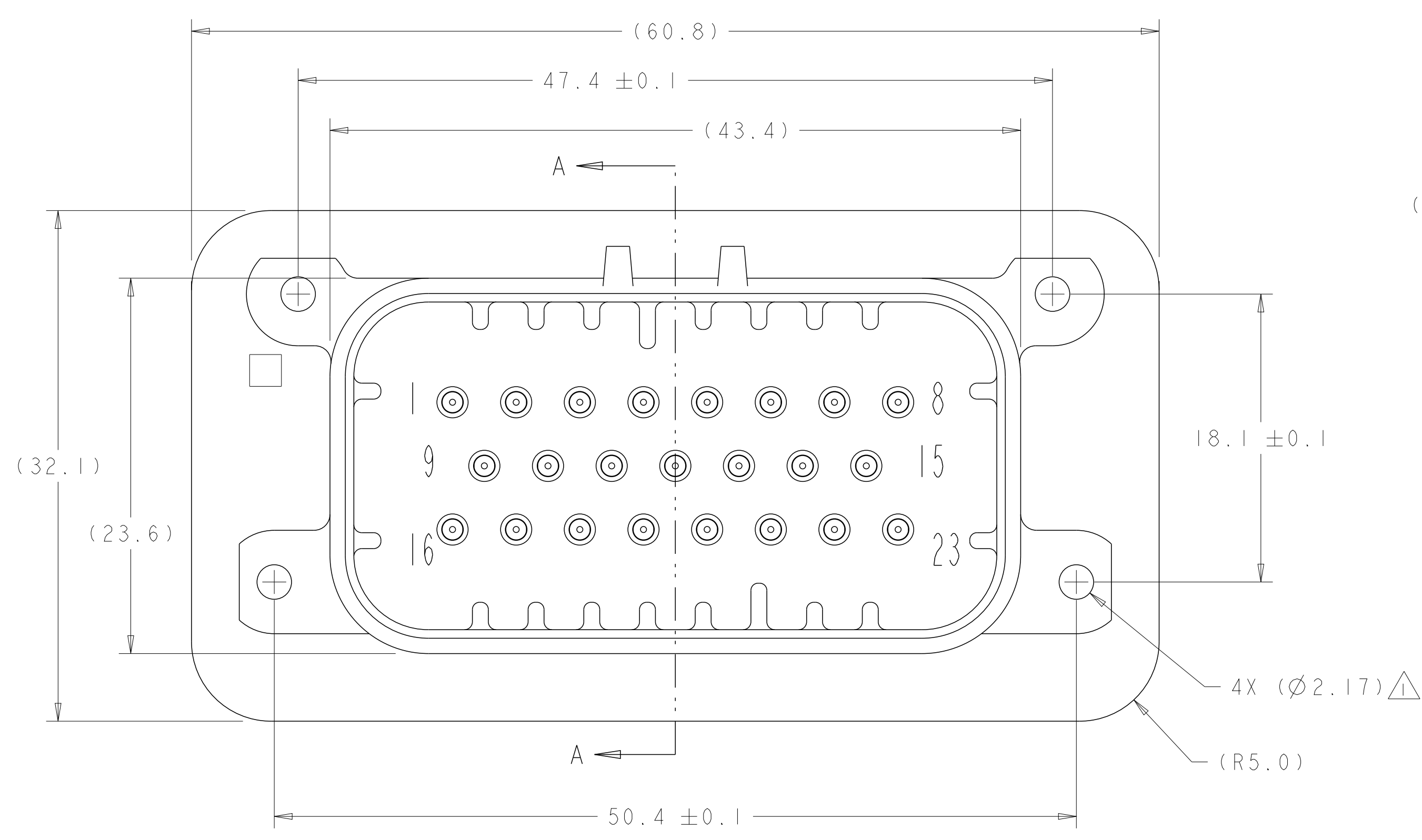

SECTION A-A

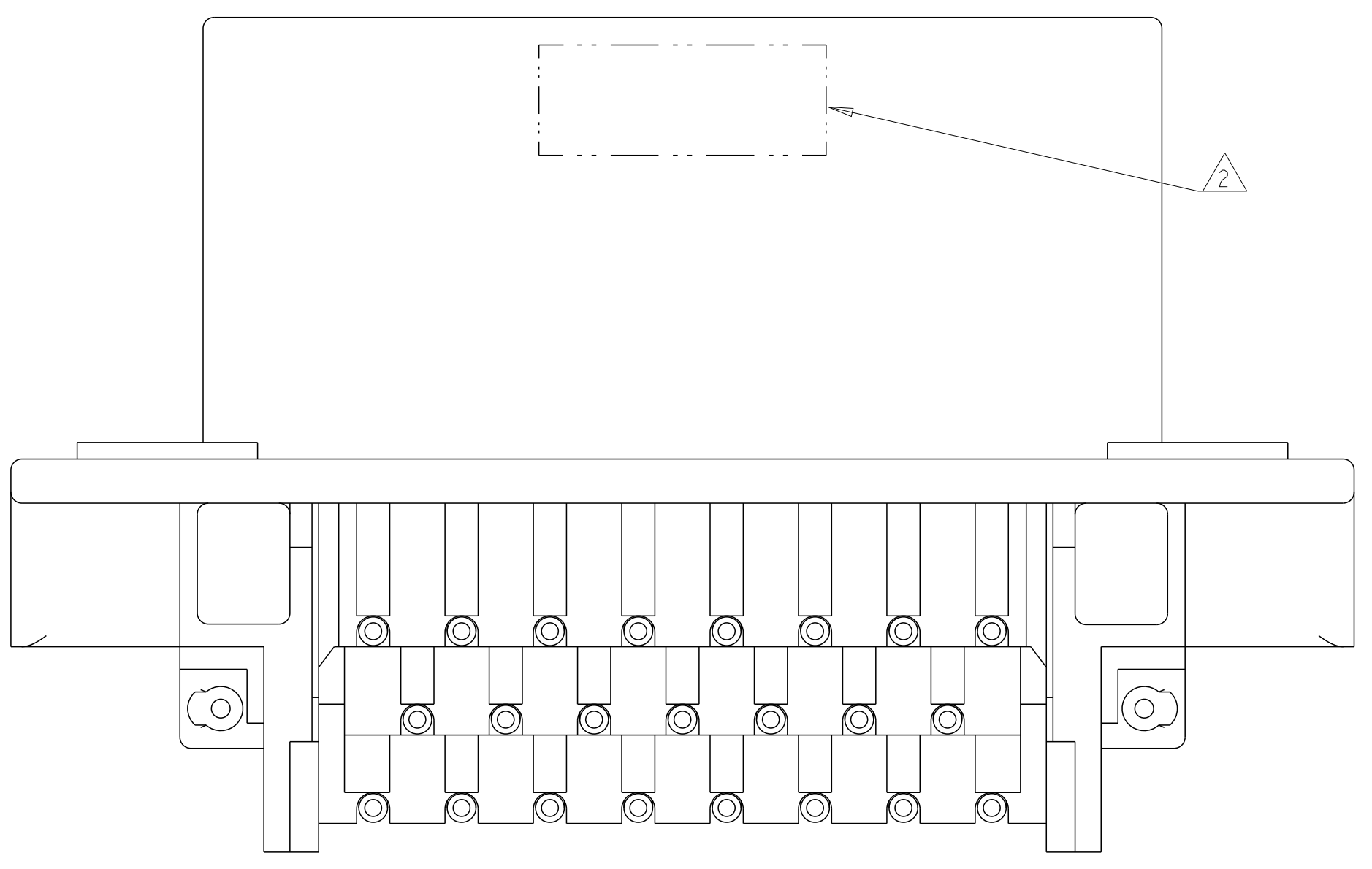

770669-1 & 1-770669-1
 KEY LOCATION AS SHOWN

GOLD	BLUE	1-770669-5
GOLD	GRAY	1-770669-4
GOLD	NATURAL	1-770669-2
GOLD	BLACK	1-770669-1
TIN	BLUE	770669-5
TIN	GRAY	770669-4
TIN	NATURAL	770669-2
TIN	BLACK	770669-1
PLATING	HEADER COLOR/3	PART NUMBER

THIS DRAWING IS A CONTROLLED DOCUMENT. DWN: R. VESTAL 31DEC2002
 CHK: D. CROWE 31DEC2002
 APVD: D. CROWE 31DEC2002

DIMENSIONS:		TOLERANCES UNLESS OTHERWISE SPECIFIED:	
mm	0 PLC	±	
	1 PLC	±0.2	
	2 PLC	±	
	3 PLC	±	
	4 PLC	±	
	ANGLES	±	
	FINISH	±	

MATERIAL: 4. FINISH: 4.

PRODUCT SPEC: 108-1329
 APPLICATION SPEC: 114-16016
 WEIGHT: 28.74g

CUSTOMER DRAWING

TE Connectivity
 NAME: HEADER ASSEMBLY, 23 POSITION, RIGHT ANGLE AMPSEAL
 SIZE: A1 CAGE CODE: 100779 DRAWING NO: 770669
 RESTRICTED TO: 1 OF 2 SHEET REV: K13

REVISIONS				
P.	LTN.	DESCRIPTION	DATE	APVD.
-	-	SEE SHEET 1	-	-

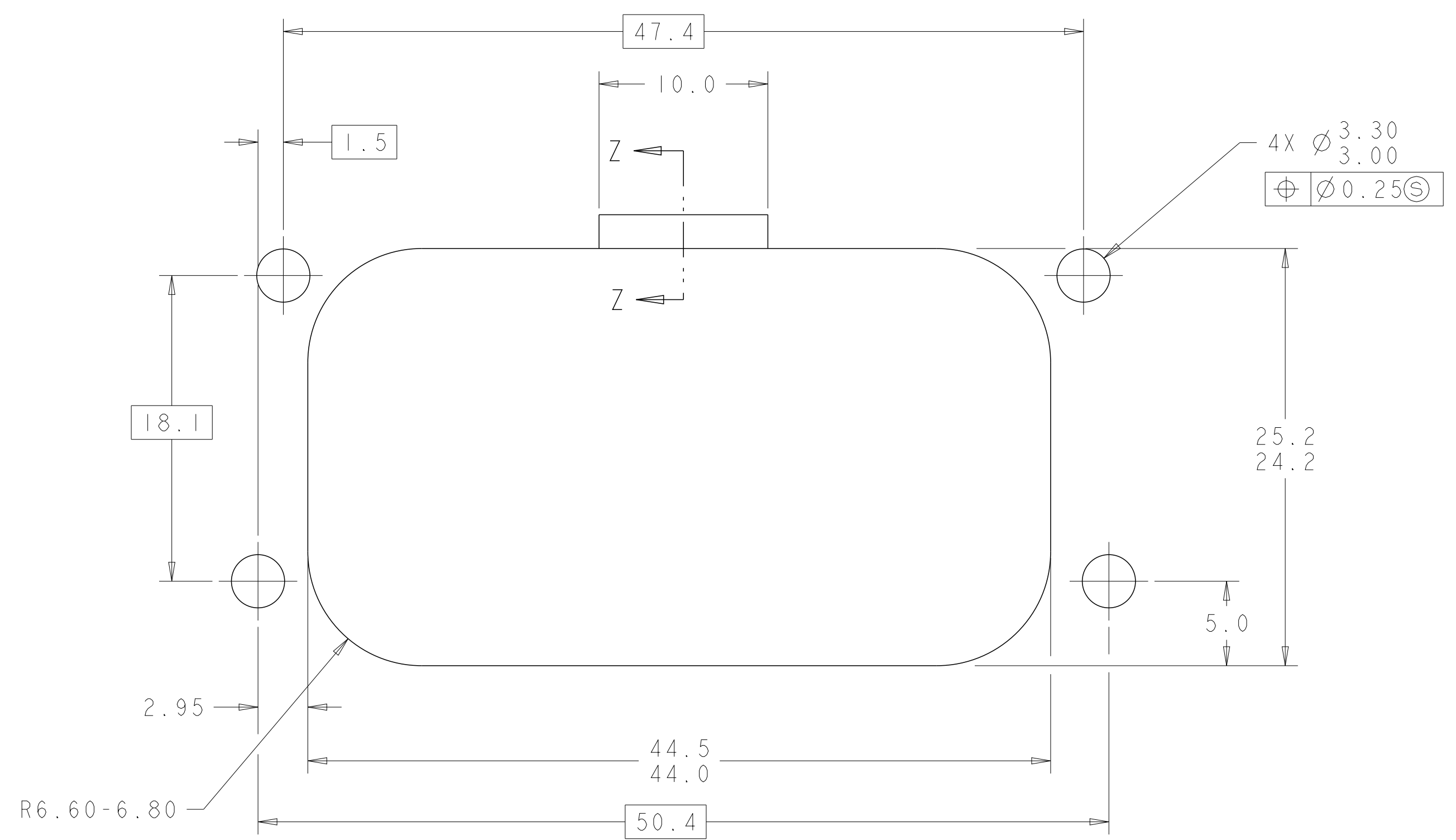

RECOMMENDED MOUNTING HOLE LAYOUT FOR 5.0 MAX THICK PANEL

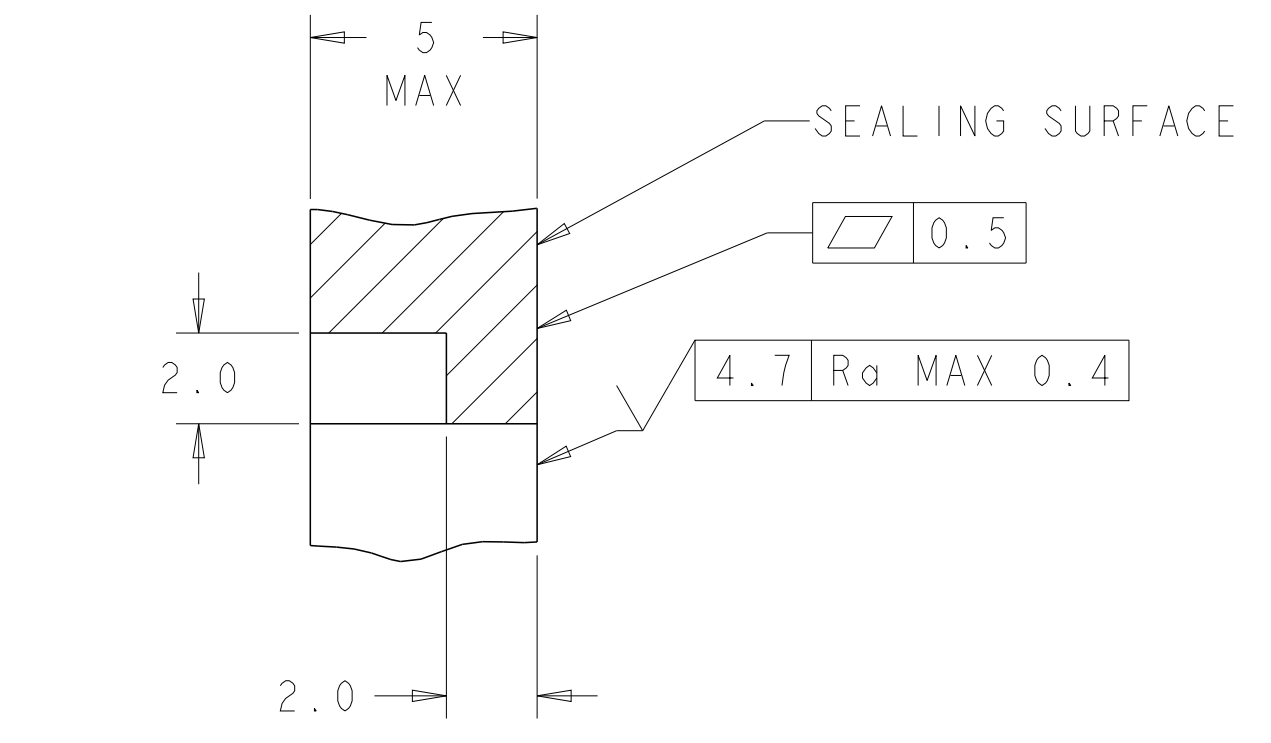

SECTION Z-Z
 OPTIONAL CONSTRUCTION IF THICKNESS IS GREATER THAN 2.0
 SCALE 6:1

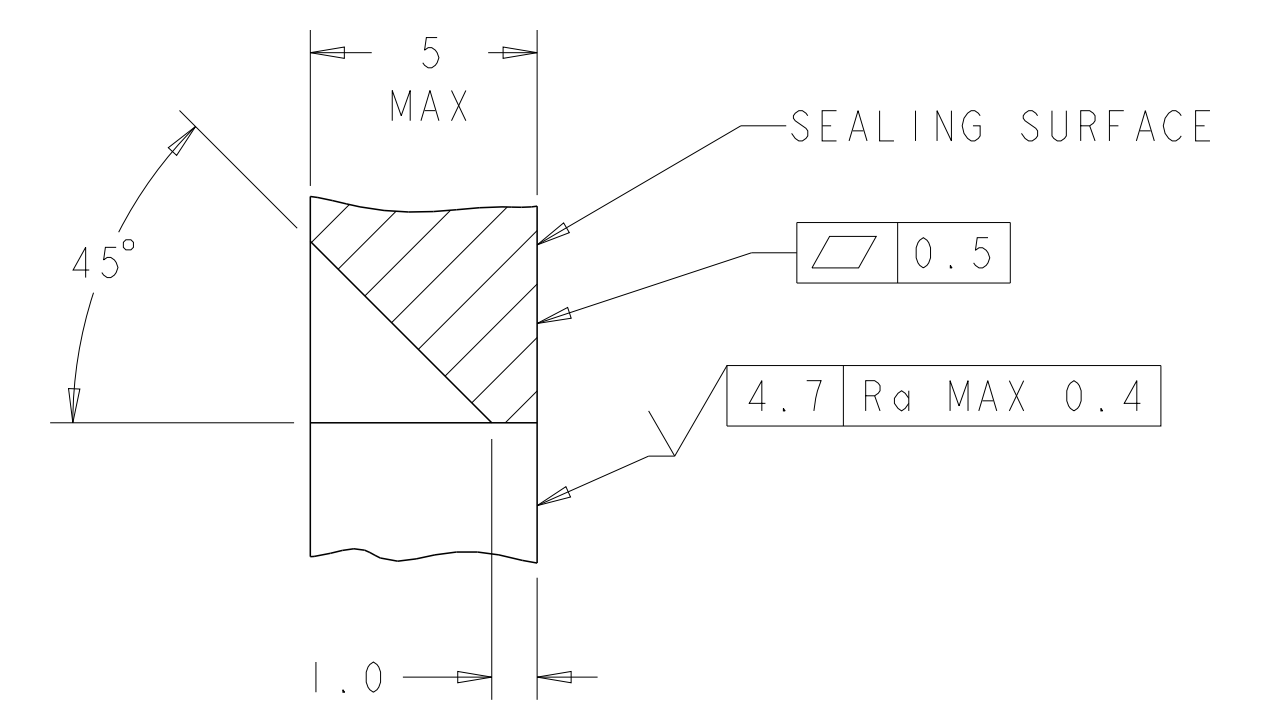

SECTION Z-Z
 OPTIONAL CONSTRUCTION IF THICKNESS IS GREATER THAN 2.0
 SCALE 6:1

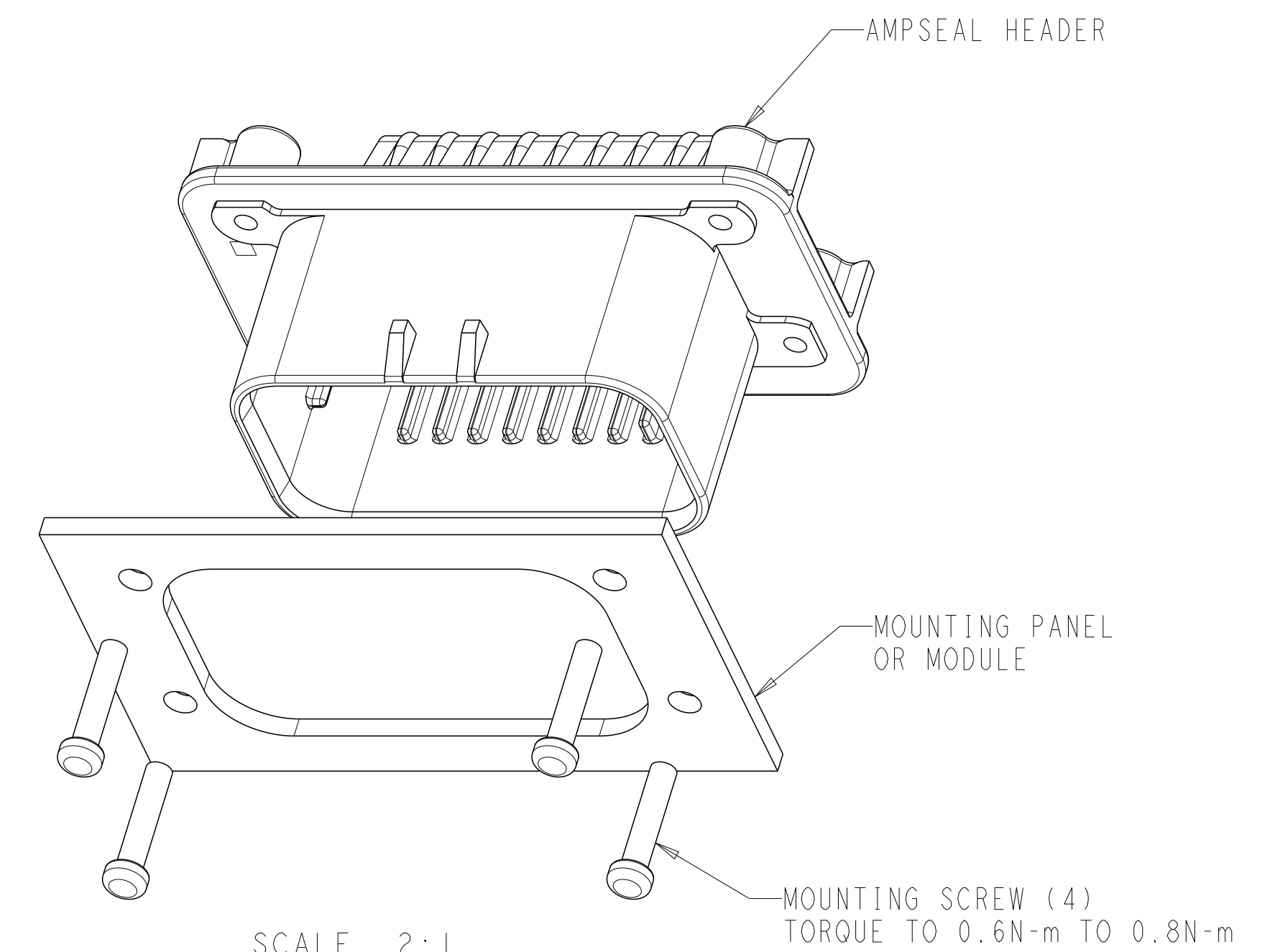

SCALE 2:1

MOUNTING SCREW (4)
 TORQUE TO 0.6N-m TO 0.8N-m

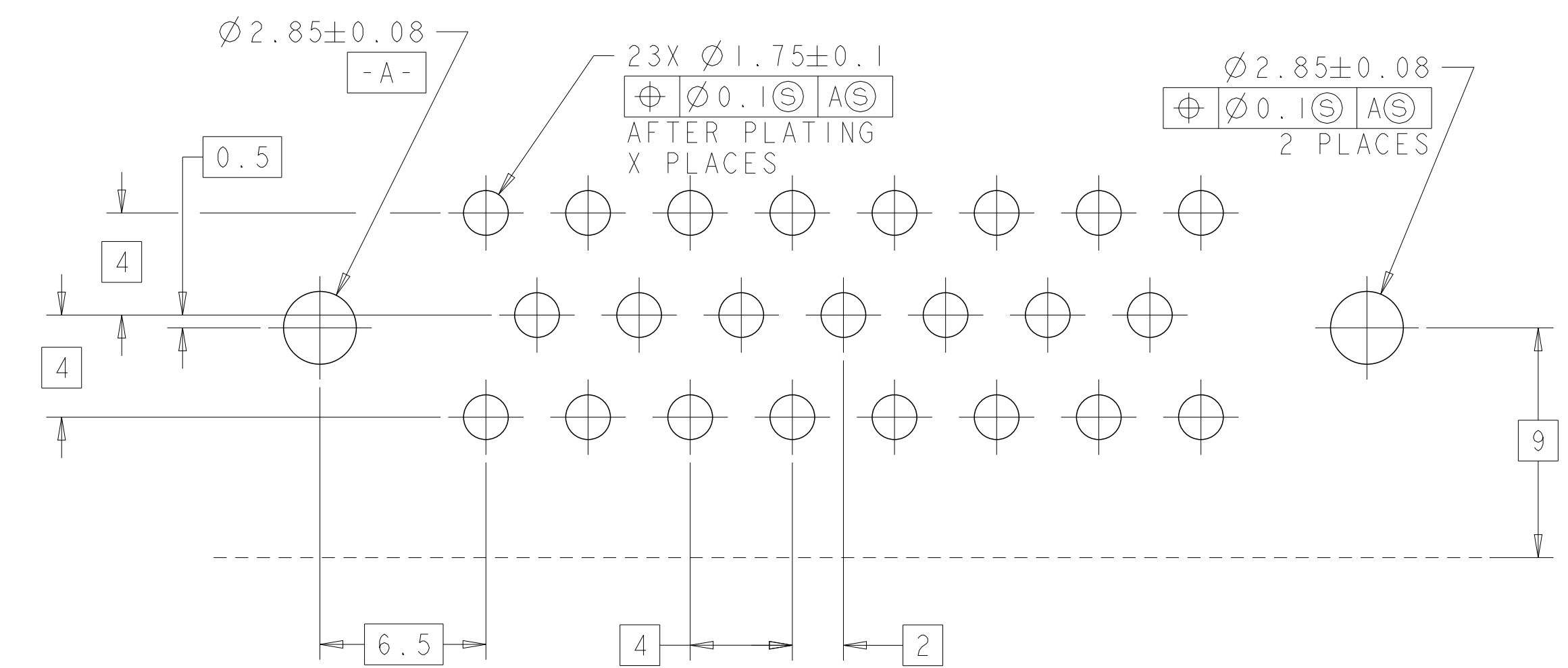

RECOMMENDED P.C. BOARD LAYOUT FOR 1.57 THICK P.C. BOARD

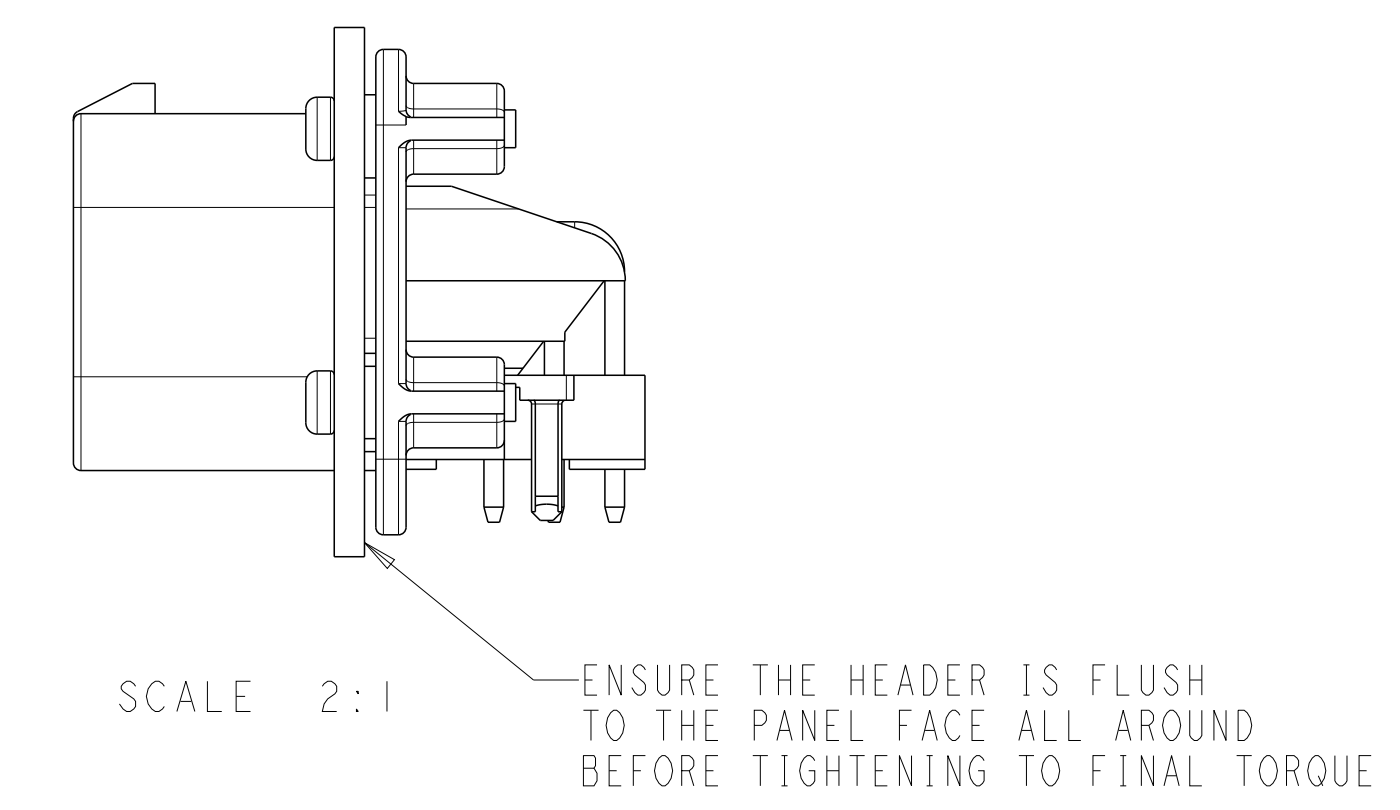

SCALE 2:1

ENSURE THE HEADER IS FLUSH TO THE PANEL FACE ALL AROUND BEFORE TIGHTENING TO FINAL TORQUE

THIS DRAWING IS A CONTROLLED DOCUMENT.		DWN R. VESTAL 31DEC2002 CHK D. CROWE 31DEC2002 APVD D. CROWE 31DEC2002	TE Connectivity	
DIMENSIONS: mm 0 PLC ± 1 PLC ±0.2 2 PLC ± 3 PLC ± 4 PLC ± ANGLES ± FINISH ±		NAME: HEADER ASSEMBLY, 23 POSITION, RIGHT ANGLE AMPSEAL PRODUCT SPEC: 108-1329 APPLICATION SPEC: 114-16016 WEIGHT: 28.74g		SIZE: A1 CAGE CODE: 770669 CUSTOMER DRAWING
MATERIAL: -		RESTRICTED TO: - SCALE: 2:1 SHEET 2 OF 2 REV: K13		