



Product Change Notification

Current Date: 31-May-2017

TE Connectivity

Product Change Notification: E-17-007792

PCN Date: 30-MAY-17

Customer: TTI Inc(0000139702)

Location: WORLDWIDE

Agreement: Agreement Unknown

TE would like to inform you of the following change(s) to the listed TE Connectivity Product. In case of any further questions about this change(s), please contact your TE Connectivity Sales Engineer. Affected part, drawing and/or specification numbers are listed on the attached sheet(s).

General Product Description:
2293782 AMPSEAL Plug Assembly

Description of Changes
The 27.6 dimension shown on the front view is being replace with a column in the CONNECTOR SIZE Table showing the actual connector height dimension. This is being done because the current generic dimension does not accurately reflect the differences between the four connector sizes
Other attachments: 2293782 Customer Drawing update

Reason for Changes:	
Product Improvement.	
Estimated Dates:	
Last Order Date (Obsolete Parts Only):	First Date To Ship (Changed Parts Only):

Last Ship Date (Obsolete Parts Only):	Last Date for Mixed Shipments: (Changed Parts Only):
	No Mixed Shipments

The documents listed below are being modified. Related parts that are not explicitly listed on this PCN are not being modified or discontinued as per the PCN. The Last Order Date, Last Ship Date, First Date to Ship Changed Parts and last date for Mixed Shipments apply only to parts explicitly listed on this PCN.

Note: This PCN contains only document changes, these changes do not affect the form, fit or function of the parts referenced.

Customer Drawing(s) Being Modified:

Drawing Number	Related Part Number	Customer Part Number	Current Revision	New Revision
2293782	770680-1	TYC770680-1	D	

Customer: TTI Inc(1281288)

Location: Fort Worth

Agreement Number: TTI002

The documents listed below are being modified. Related parts that are not explicitly listed on this PCN are not being modified or discontinued as per the PCN. The Last Order Date, Last Ship Date, First Date to Ship Changed Parts and last date for Mixed Shipments apply only to parts explicitly listed on this PCN.

Customer Drawing(s) Being Modified:

Drawing Number	Related Part Number	Customer Part Number	Current Revision	New Revision
2293782	770680-1		D	

Customer: Shanghai TTI EElectronics Co Ltd(1405773)

Location: Shanghai

Agreement Number: Agreement Unknown

The documents listed below are being modified. Related parts that are not explicitly listed on this PCN are not being modified or discontinued as per the PCN. The Last Order Date, Last Ship Date, First Date to Ship Changed Parts and last date for Mixed Shipments apply only to parts explicitly listed on this PCN.

Customer Drawing(s) Being Modified:

Drawing Number	Related Part Number	Customer Part Number	Current Revision	New Revision
2293782	770680-1		D	

Customer: TTI Electronics Asia Pte Ltd.(2771300)

Location: Singapore

Agreement Number: Agreement Unknown

The documents listed below are being modified. Related parts that are not explicitly listed on this PCN are not being modified or discontinued as per the PCN. The Last Order Date, Last Ship Date, First Date to Ship Changed Parts and last date for Mixed Shipments apply only to parts explicitly listed on this PCN.

Customer Drawing(s) Being Modified:

Drawing Number	Related Part Number	Customer Part Number	Current Revision	New Revision
2293782	770680-1		D	

Customer: TTI Inc(168830)

Location: Fort Worth

Agreement Number: TTI003

The documents listed below are being modified. Related parts that are not explicitly listed on this PCN are not being modified or discontinued as per the PCN. The Last Order Date, Last Ship Date, First Date to Ship Changed Parts and last date for Mixed Shipments apply only to parts explicitly listed on this PCN.

Customer Drawing(s) Being Modified:

Drawing Number	Related Part Number	Customer Part Number	Current Revision	New Revision
2293782	770680-1		D	

Customer: TTI Inc.(1305175)

Location: Maisach-Gernlinden

Agreement Number: TTI001

The documents listed below are being modified. Related parts that are not explicitly listed on this PCN are not being modified or discontinued as per the PCN. The Last Order Date, Last Ship Date, First Date to Ship Changed Parts and last date for Mixed Shipments apply only to parts explicitly listed on this PCN.

Customer Drawing(s) Being Modified:

Drawing Number	Related Part Number	Customer Part Number	Current Revision	New Revision
----------------	---------------------	----------------------	------------------	--------------

2293782	770680-1	TYC770680-1	D	
-------------------------	----------	-------------	---	--

REVISIONS					
P.	LTN.	DESCRIPTION	DATE	OWN.	APVD.
C		REVISED PER ECO-15-017333	29DEC2015	DD	DS
D		REVISED PER ECO-16-006990	16MAY2016	DD	DS

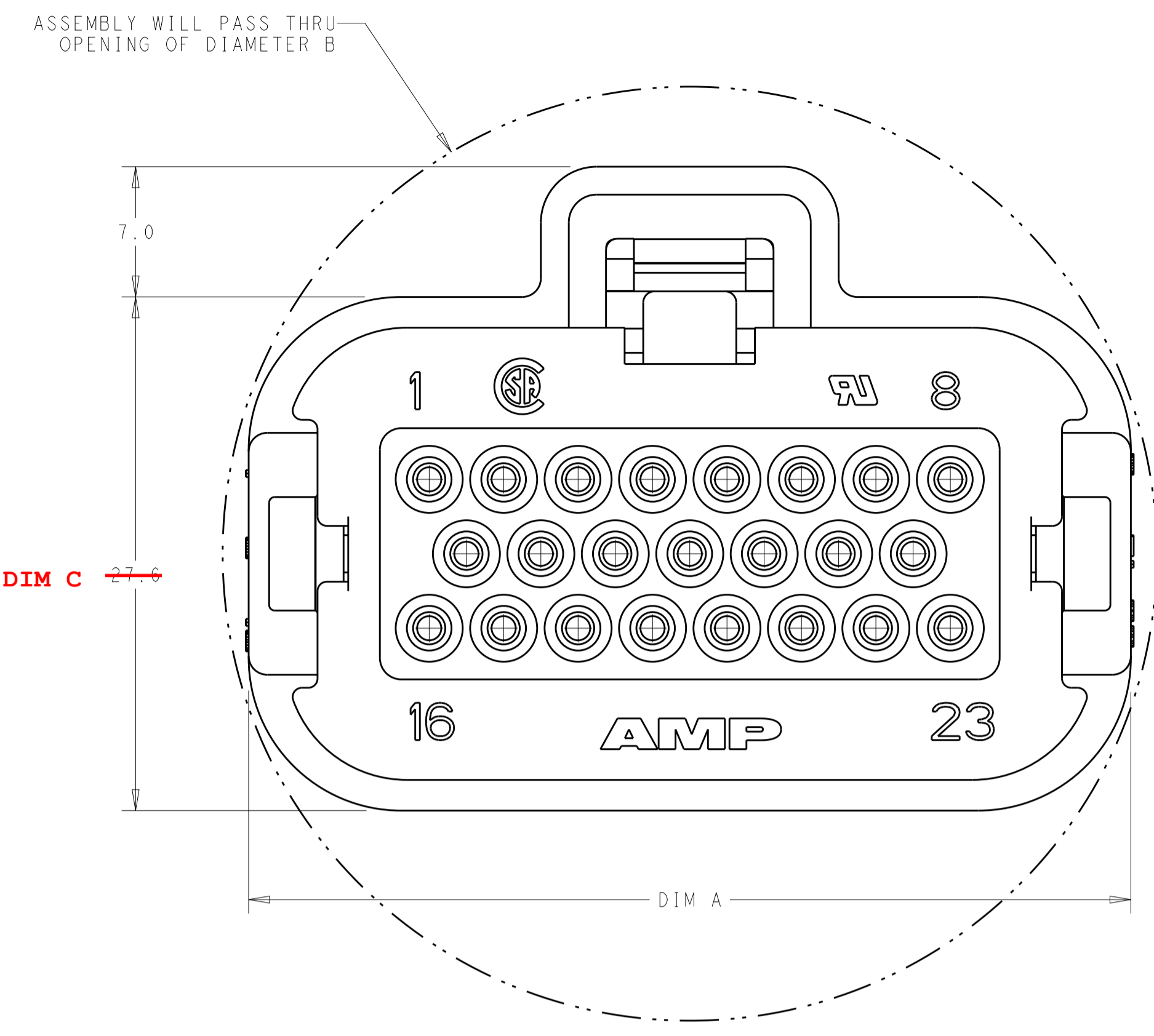
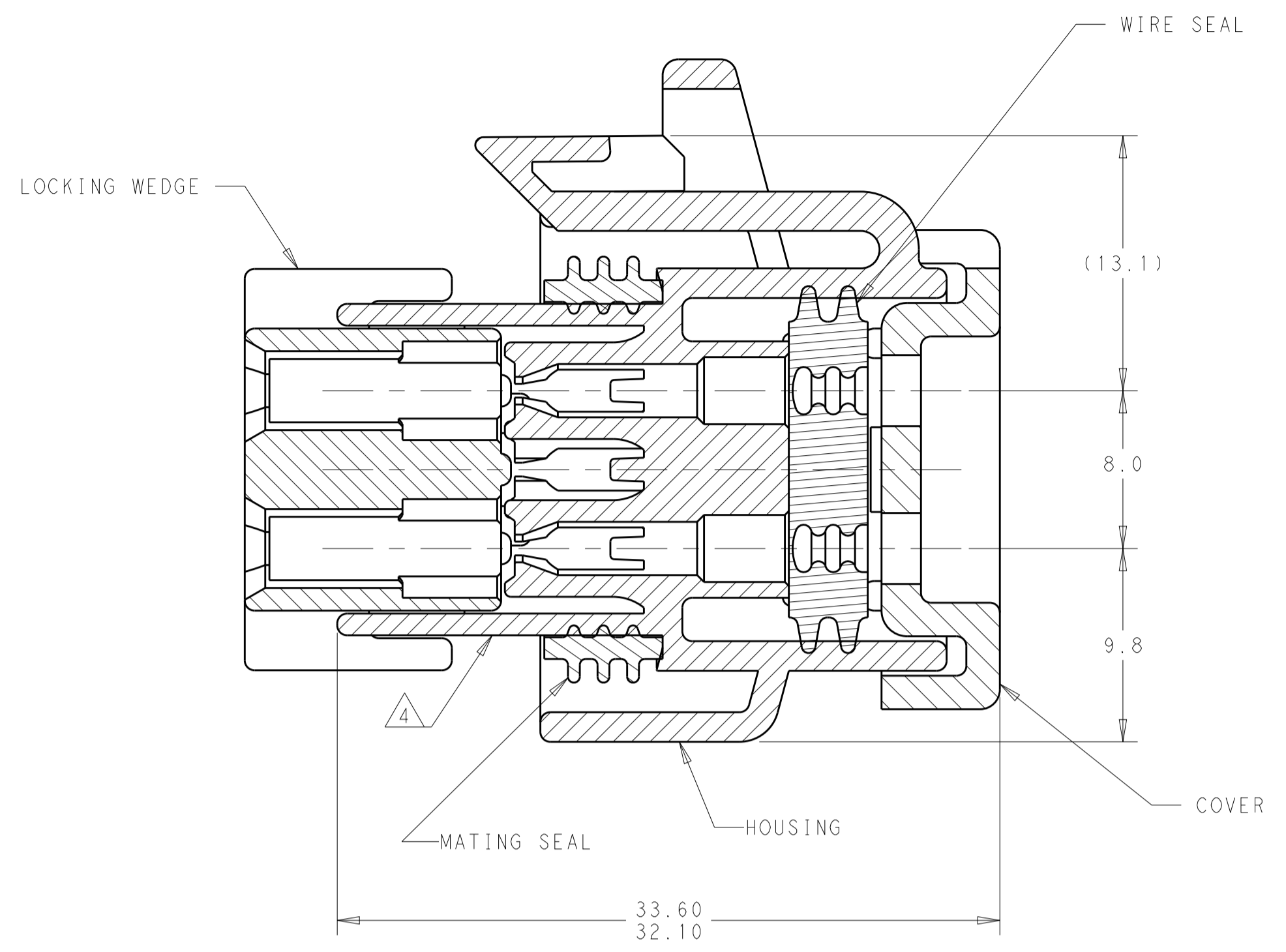

- MATERIAL: HOUSING - UL94V-0 PBT
 LOCKING WEDGE - UL94V-0 PBT, RED
 COVER - UL94V-0 PBT, BLACK
 MATING SEAL - SILICONE
 WIRE SEAL - SILICONE
- HOUSING COLORS ARE MECHANICALLY KEYED TO MATE WITH IDENTICALLY COLORED HEADER ASSEMBLIES.
- PLUG USES REELED TERMINAL 770520 OR LOOSE PIECE TERMINAL 770854.
- DATE CODE ON THIS SURFACE. USES 5 DIGIT CODE: FIRST 2 DIGITS = YEAR, SECOND 2 DIGITS = WEEK, LAST DIGIT = DAY.
- CIRCUITS 3, 7, 16, 17, 21, 22 BLOCKED
- OPTIONAL VOID CORING ON 35 POSITION PLUG ASSEMBLY 776164.

23-POSITION CONNECTOR SHOWN, SEE TABLE BELOW FOR ALTERNATE DIMENSIONS.

CONNECTOR SIZE	A	B	C
8-POSITION	27.4	40	27.50
14-POSITION	35.4	44	27.60
23-POSITION	47.4	50	27.60
35-POSITION	63.4	66	27.45

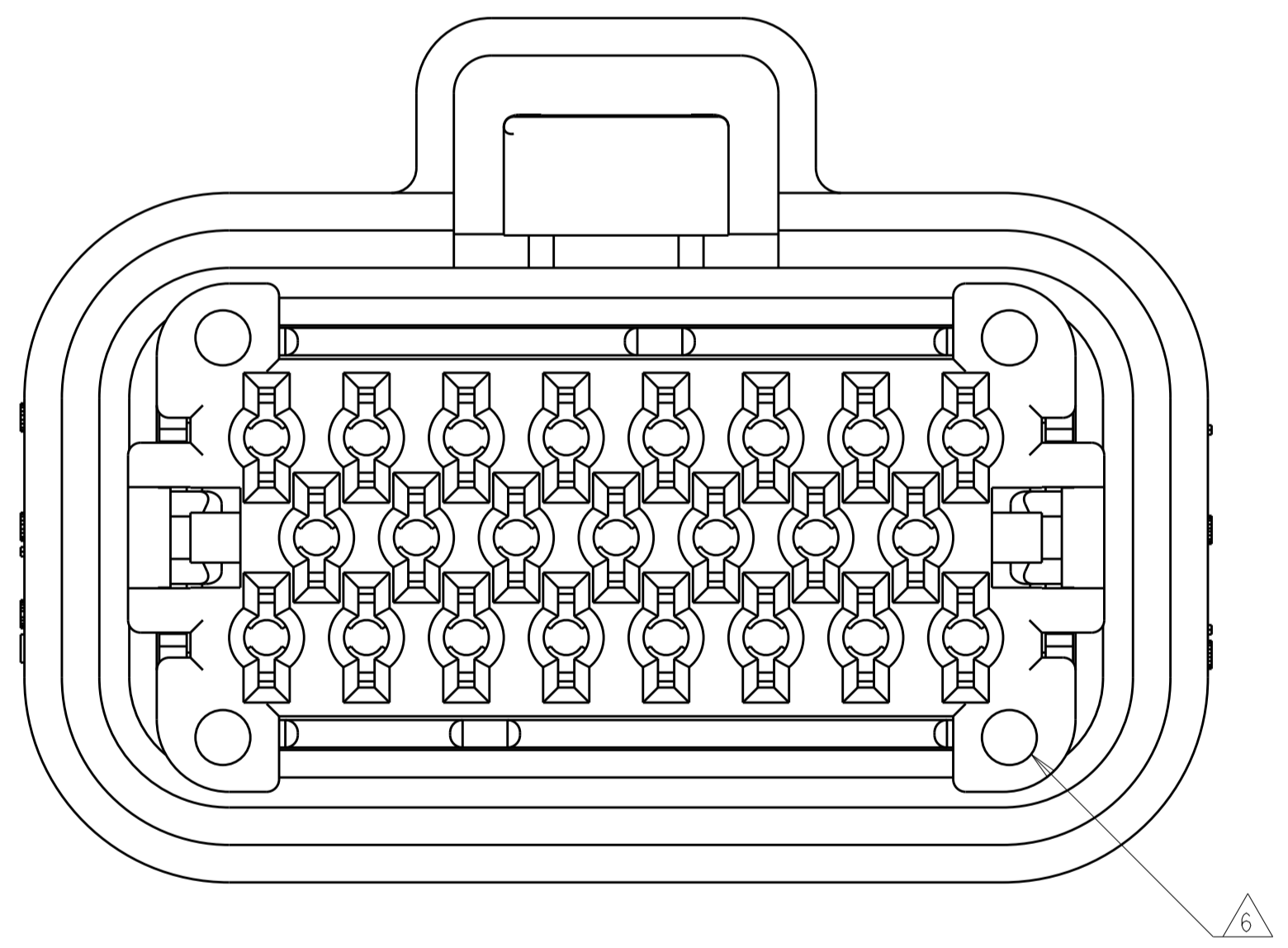

MATING HEADER	RIGHT-ANGLE	WIRE SEAL COLOR	MATING SEAL COLOR	HOUSING COLOR	NO. OF POSITIONS	PART NUMBER
776230, 776231	776180, 776163	RED	RED	ORANGE	35-POSITION	776164-6
				BLUE		776164-5
				GREY		776164-4
				NATURAL		776164-2
776200, 776228	770669, 776087	GREEN	RED	BLACK	23-POSITION	776164-1
				BLUE		770680-5
				GREY		770680-4
				BLACK		770680-3
776261, 776262	776266, 776267	GREEN	GREEN	NATURAL	14-POSITION	770680-2
				BLACK		770680-1
				BLUE		776273-5
				GREY		776273-4
776275, 776276	776279, 776280	YELLOW	YELLOW	NATURAL	8-POSITION	776273-2
				BLACK		776273-1
				NATURAL		776286-2
				BLACK		776286-1

THIS DRAWING IS A CONTROLLED DOCUMENT. OWN: A. MARTIN 11JUN2015
 CHK: D. STRAUSSER 29JUN2015
 APVD: G. BROWN 29JUN2015

TE Connectivity

PLUG ASSEMBLY, AMPSEAL FAMILY DRAWING

SIZE: A100779 C=2293782
 SCALE: 4:1 SHEET 1 OF 2 REV D

REVISIONS				
P.	LTN.	DESCRIPTION	DATE	APVD.
-	-	SEE SHEET 1	-	-

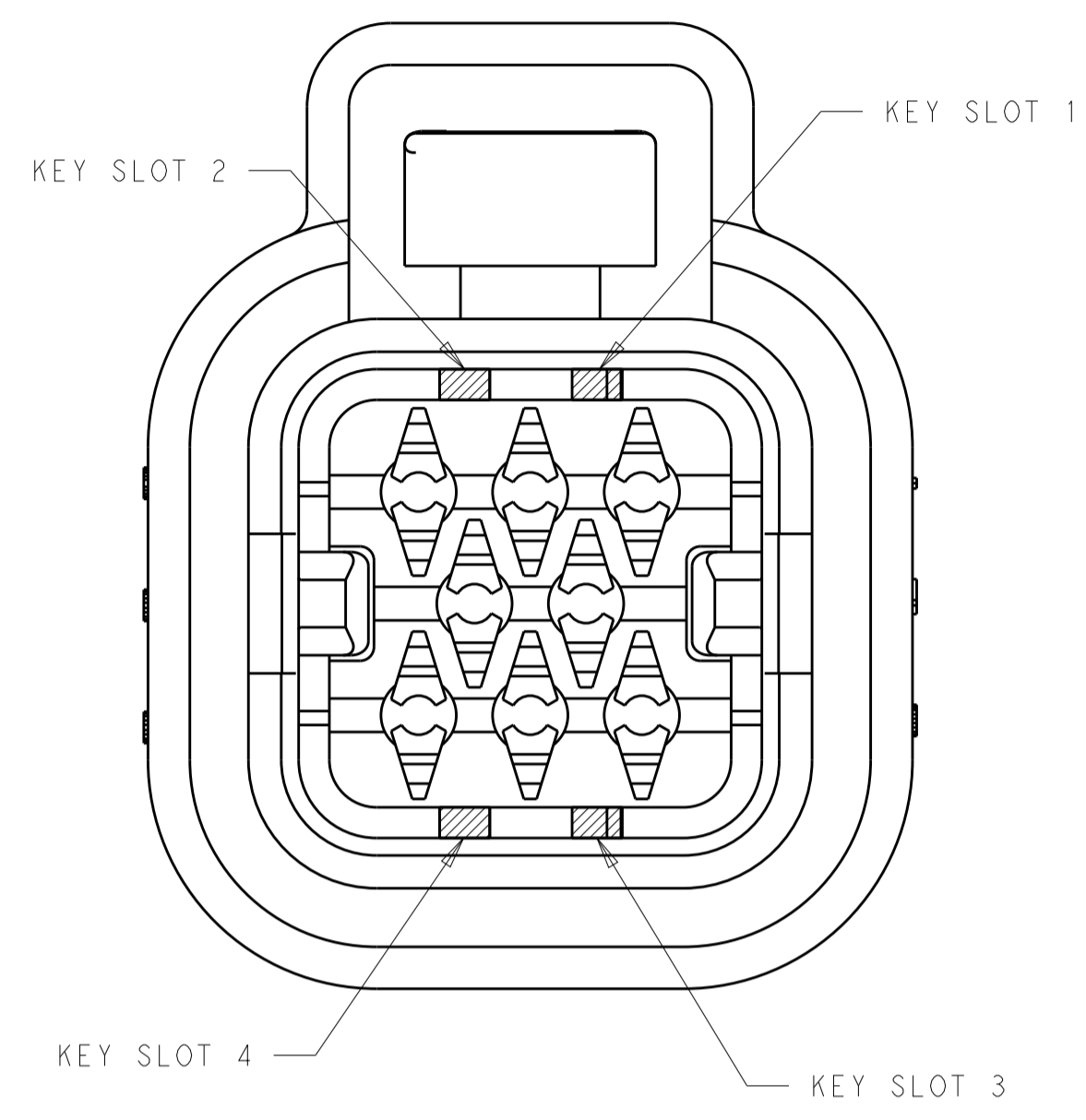

KEY SLOT LOCATION (SEE VIEW ABOVE)	COLOR	PART NUMBER
1 & 3	NATURAL	776286-2
2 & 4	BLACK	776286-1

8-POSITION CONNECTOR
KEY SLOT LOCATIONS
SCALE 4:1

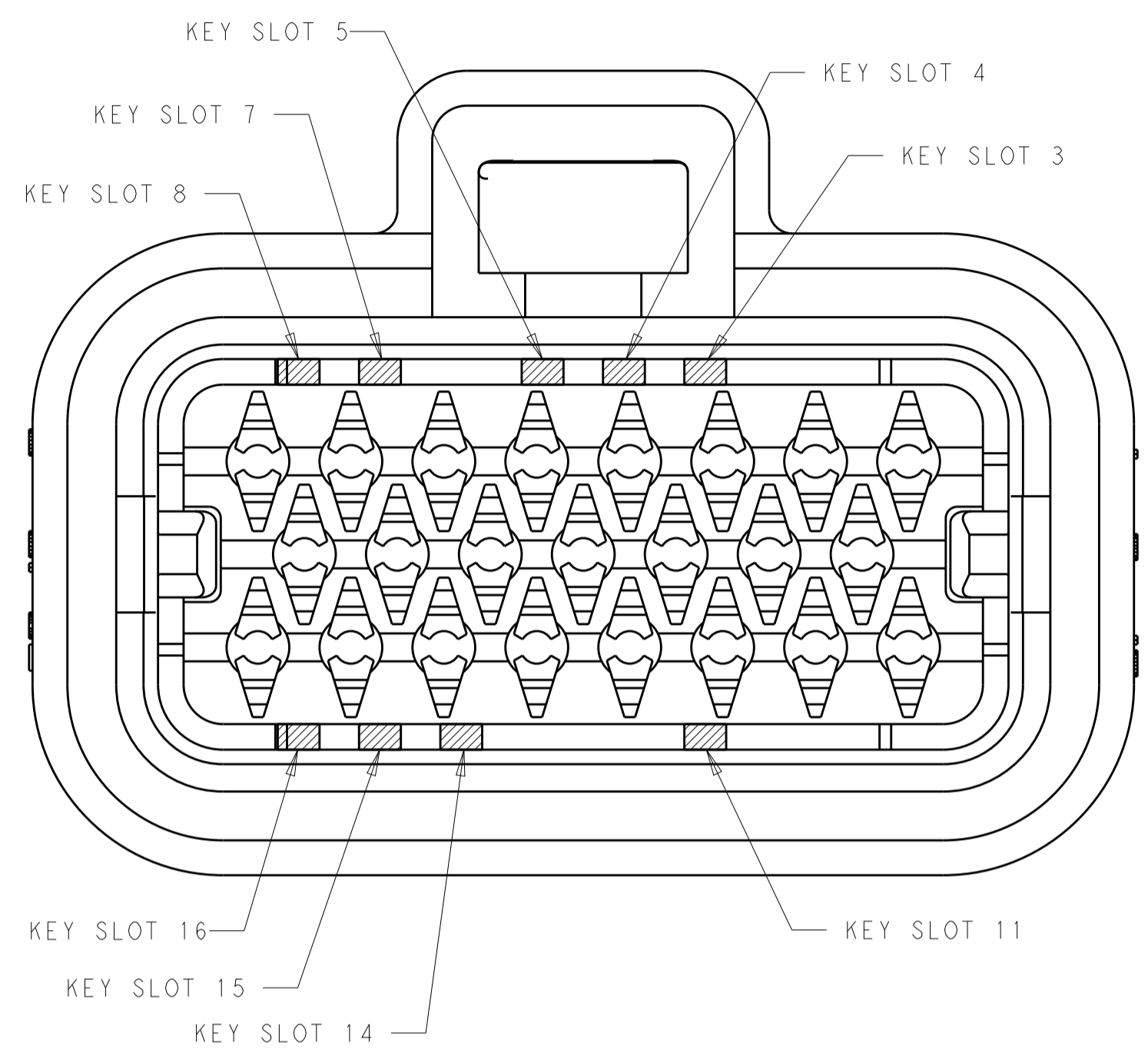

KEY SLOT LOCATION (SEE VIEW ABOVE)	COLOR	PART NUMBER
3, 8 & 16	BLUE	770680-5
7 & 15	GREY	770680-4
4 & 14	BLACK	770680-3
5 & 11	NATURAL	770680-2
4 & 14	BLACK	770680-1

23-POSITION CONNECTOR
KEY SLOT LOCATIONS
SCALE 4:1

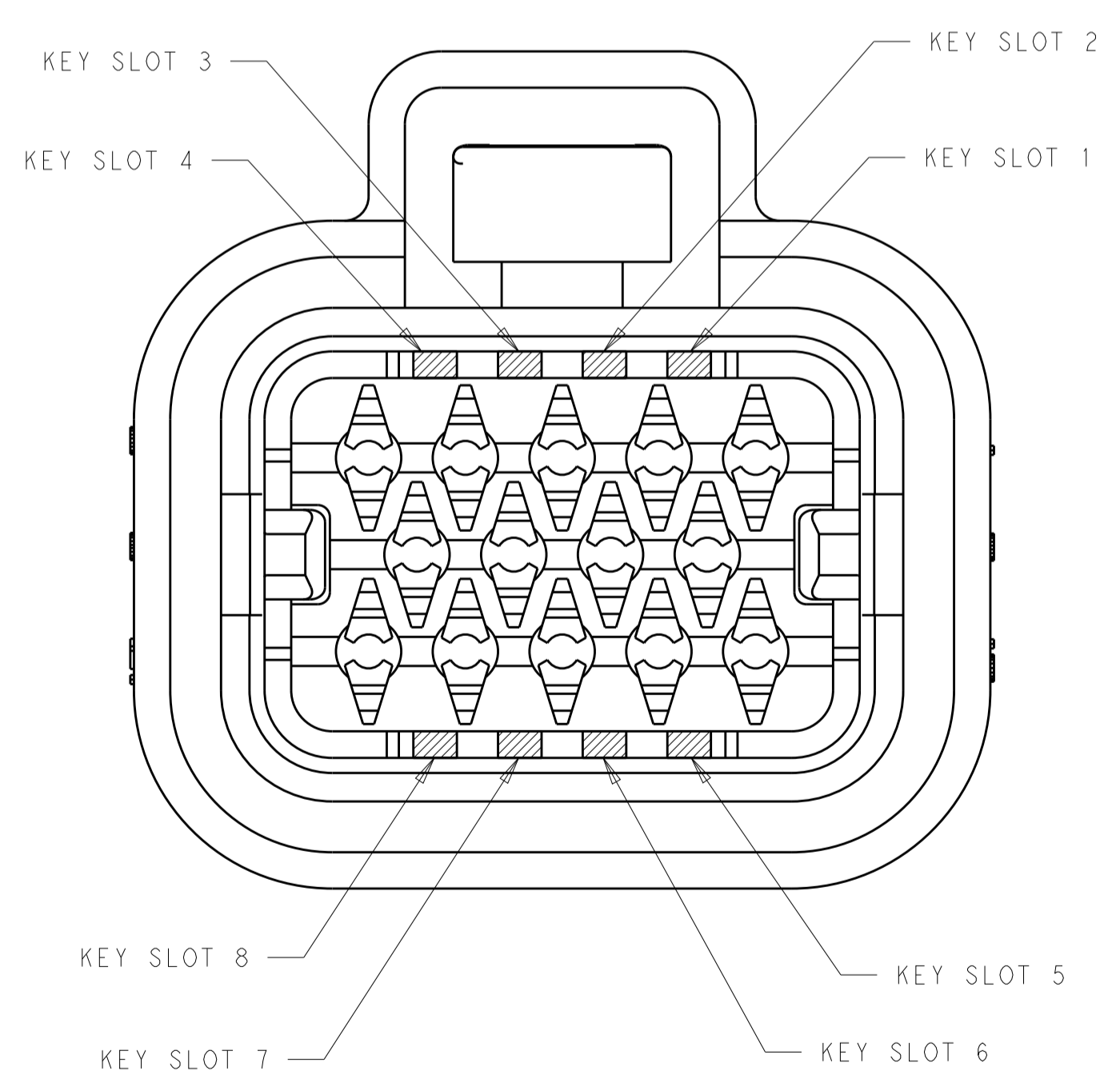

KEY SLOT LOCATION (SEE VIEW ABOVE)	COLOR	PART NUMBER
3 & 5	BLUE	776273-5
2 & 8	GREY	776273-4
1 & 6	NATURAL	776273-2
3 & 7	BLACK	776273-1

14-POSITION CONNECTOR
KEY SLOT LOCATIONS
SCALE 4:1

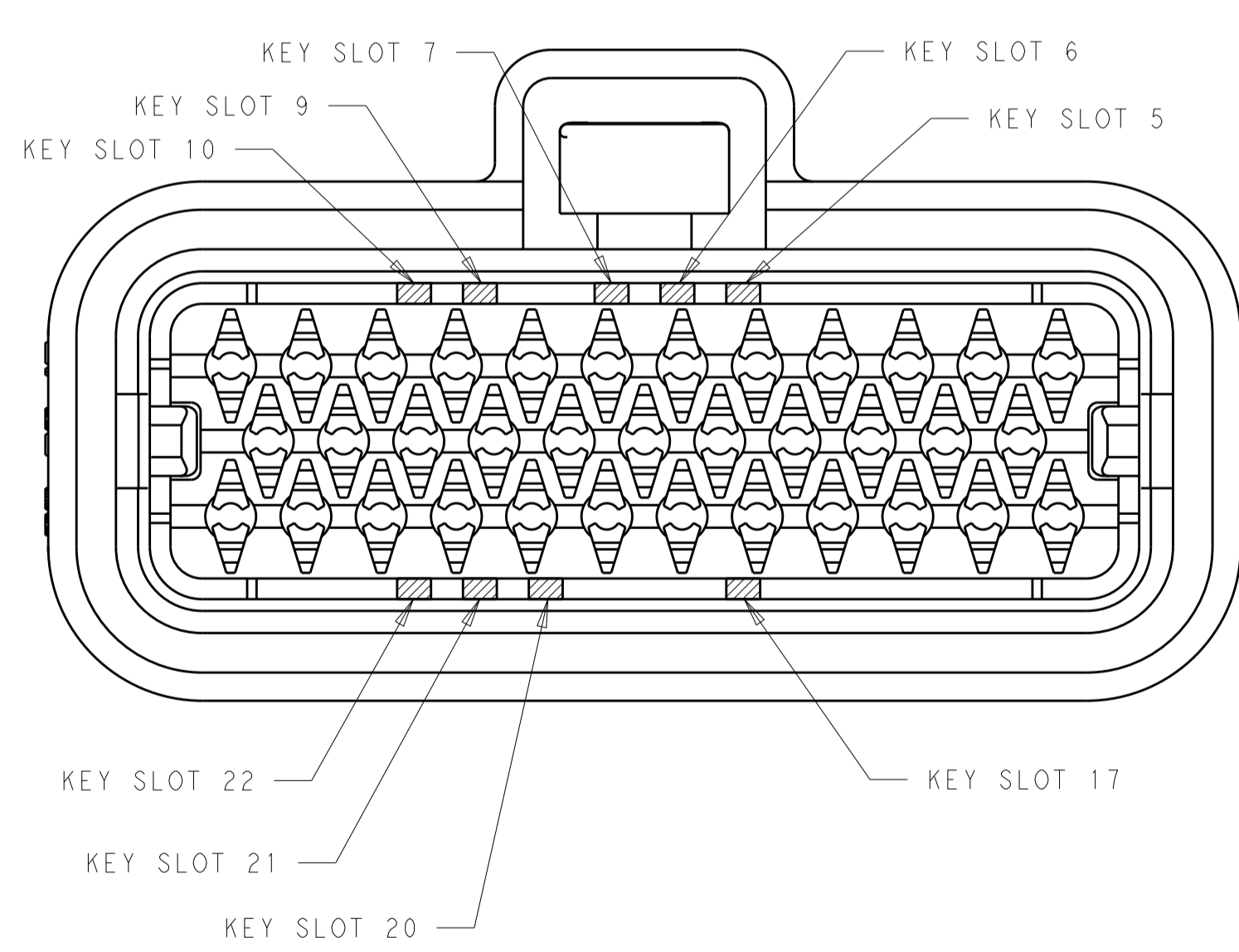

KEY SLOT LOCATION (SEE VIEW ABOVE)	COLOR	PART NUMBER
7 & 22	ORANGE	776164-6
5, 10, 22	BLUE	776164-5
9 & 21	GREY	776164-4
7 & 17	NATURAL	776164-2
6 & 20	BLACK	776164-1

35-POSITION CONNECTOR
KEY SLOT LOCATIONS
SCALE 3:1

THIS DRAWING IS A CONTROLLED DOCUMENT.		OWN: A. MARTIN 11JUN2015	TE Connectivity
DIMENSIONS: mm		CHK: D. STRAUSSER 29JUN2015	
		APVD: G. BROWN 29JUN2015	NAME: PLUG ASSEMBLY, AMPSEAL FAMILY DRAWING
TOLERANCES UNLESS OTHERWISE SPECIFIED:		PRODUCT SPEC: 108-1329	SIZE: A1
0 PLC ±		APPLICATION SPEC: 114-16016	CAGE CODE: C=2293782
1 PLC ±0.2		WEIGHT: -	RESTRICTED TO: -
2 PLC ±		CUSTOMER DRAWING	SCALE: 4:1 SHEET 2 OF 2 REV D
3 PLC ±			
4 PLC ±			
ANGLES ±			
MATERIAL: SEE SHEET 1			