



Product Change Notification

Current Date: 12-Apr-2021

TE Connectivity

Product Change Notification: E-21-003240

PCN Date: 09-APR-21

Customer: TTI, Inc. (1305175)

Location: Maisach-gernlinden

Agreement: TTI001

TE would like to inform you of the following change(s) to the listed TE Connectivity Product. In case of any further questions about this change(s), please contact your TE Connectivity Sales Engineer. Affected part, drawing and/or specification numbers are listed on the attached sheet(s).

General Product Description:

56POS. TAB HSG ASSY, JPT HOUSING, 29POS. ASSY and SEALING FOR 6 POS. 2.8MM TAB-HSG.

Description of Changes

Cross mark discontinued PNs in the BOM of affected drawing due to no sales from several years. The drawings for the listed part numbers have been modified for clarification.

Other attachments:
[963449_Customer Drawing](#)
[PCN FORM](#)
[963205_Customer Drawing](#)
[963181_Customer Drawing](#)
Reason for Changes:

Document Clarification. Since there is no sales for several years, Product Manager approved to set the PNs as discontinue.

Estimated Dates:
Last Order Date (Obsolete Parts Only):

First Date To Ship (Changed Parts Only):

Last Ship Date (Obsolete Parts Only):

Last Date for Mixed Shipments: (Changed Parts Only):

No Mixed Shipments

The documents listed below are being modified. Related parts that are not explicitly listed on this PCN are not being modified or discontinued as per the PCN. The Last Order Date, Last Ship Date, First Date to Ship Changed Parts and last date for Mixed Shipments apply only to parts explicitly listed on this PCN.

Note: This PCN contains only document changes, these changes do not affect the form, fit or function of the parts referenced.

Customer Drawing(s) Being Modified:

Drawing Number	Related Part Number	Customer Part Number	Current Revision	New Revision
963205	963205-1	TYC963205-1	C1	
963449	1-963449-2	TYC1-963449-2	D2	



PCN Description of Eng. Changes

PCN No.
OEM / CAM informed
Estimated First Date for samples

E-21-003240					
Yes					

Picture:

ILLUSTRATION OF CHANGES

Below listed PNs are Discontinued due to no sales from past several years

See PCN attachments for updated customer drawings

TCPN	Part Rev	Part Status	Reason
1-963449-1	A	Discontinued	No Sales
2-963181-1	F	Discontinued	No Sales
3-963181-1	F	Discontinued	No Sales
5-963181-1	F	Discontinued	No Sales
4-963181-1	F	Discontinued	No Sales
963205-2	C	Discontinued	No Sales

Drw. No.	Exsiting Rev	New Rev	Drw Status
963449-C	D2	D3	Active
963181-C	F	F1	Active
963205-C	C1	C2	Active

x	Potential Impact for Customer	x	Product Type	x	Change Type	x	Kind of Change	x	Change Feature	Remark / Free text
x	Revision adapted	x	CONNECTOR KIT	x	No Form, Fit, Function	x	Drawing	x	Drawing Change Revision Adjustment	Cross mark above listed PNs in BOM of customer drawings to set as OBSOLETE
						x	Status Change	x	Obsolete	Obsolescence of listed PNs since there is no sales from past several years.

REVISIONS		DATE	DRW	APP
P	UR	21JUL1993	S.G.	-
C1	Neues Format war DIN A4	18MAY1995	1.S	-
F	Abstandsrippen verarbeitet			
F1	2-963181-1,3-1,4-1 und 5-1 Pns are OBSOLETE	21MAR2021	JUH	KP

PCB LAYOUT
PCB Lochbild

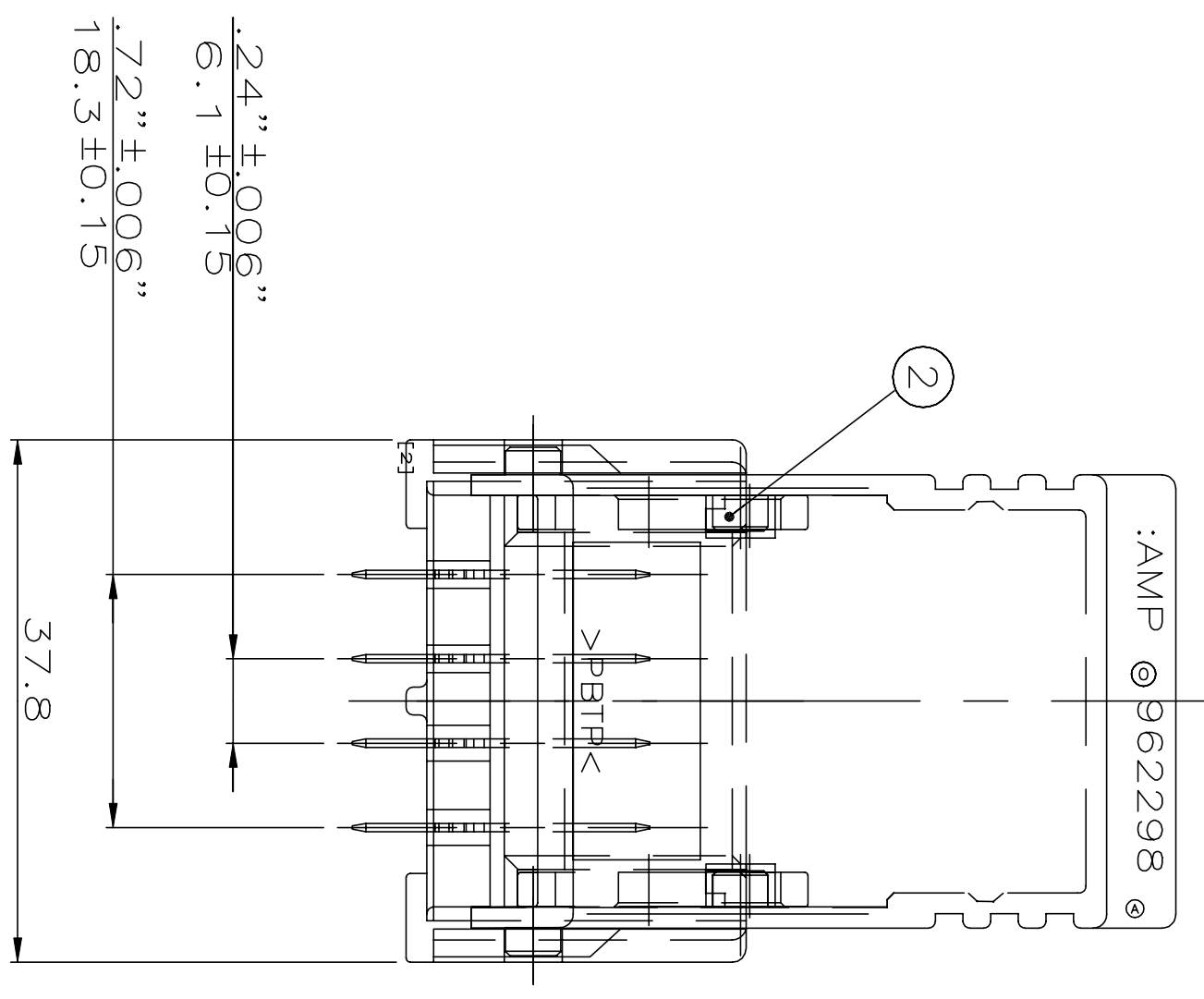
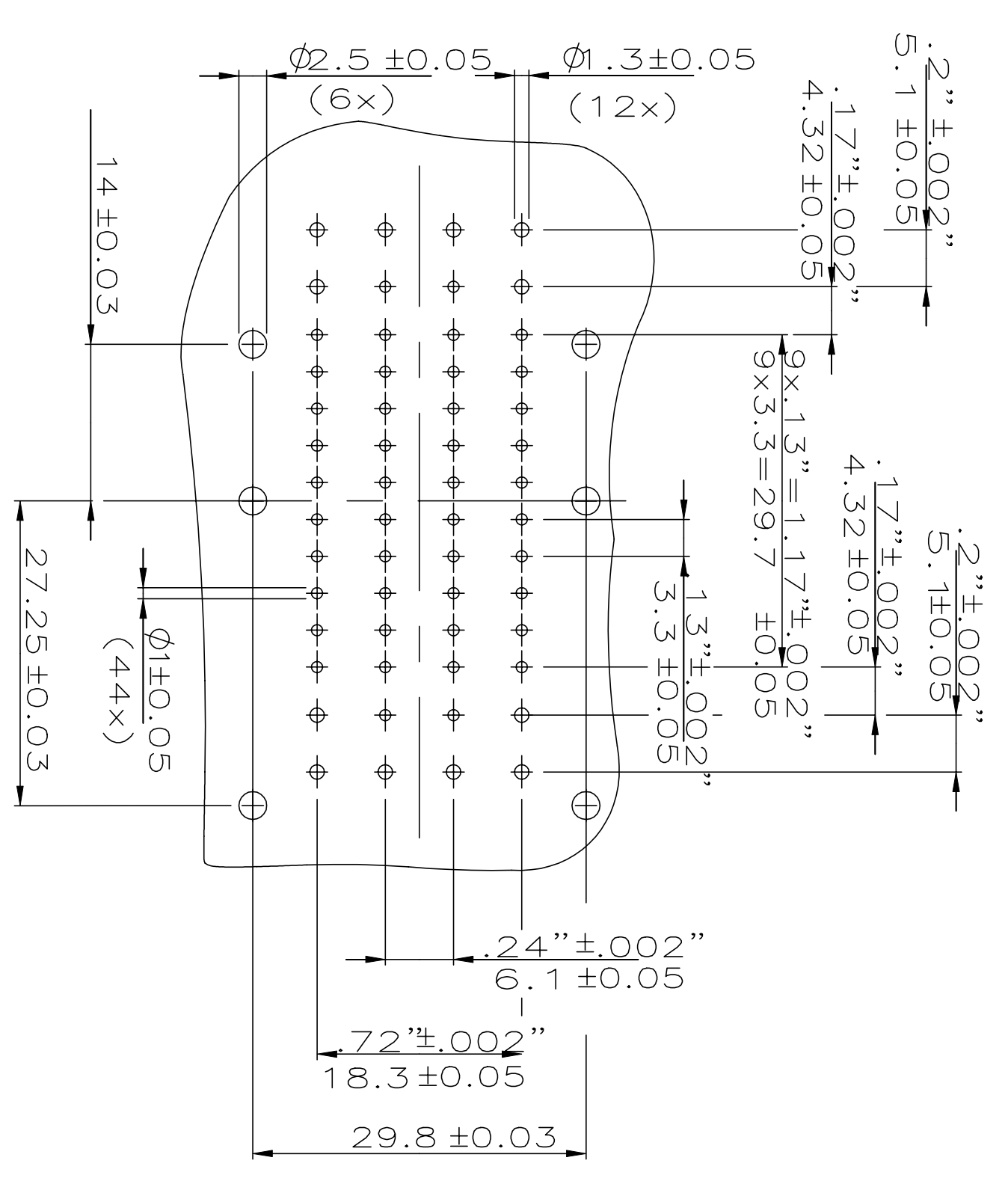

FOR CYLSELF-TAPPING SCREW: DIN 7971 ST 2,2x6,5-C-H
Für Zylinder Blechschraube: DIN 7971 ST 2,2x6,5-C-H

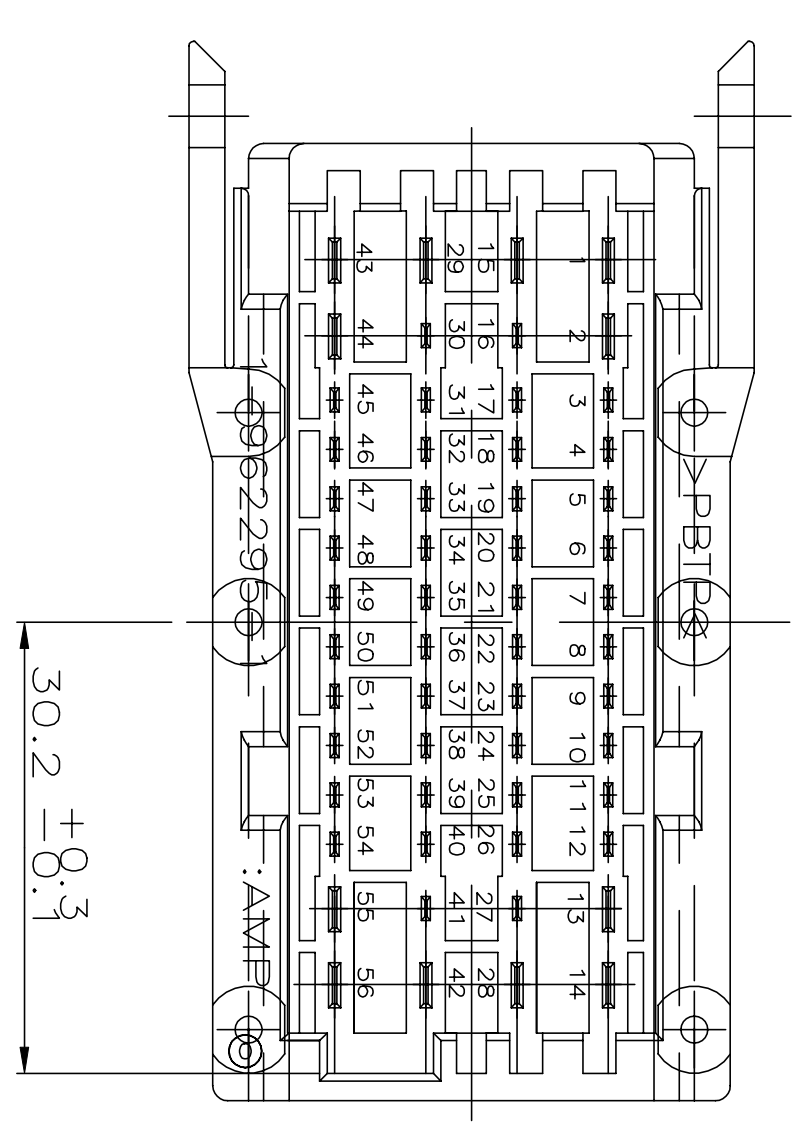
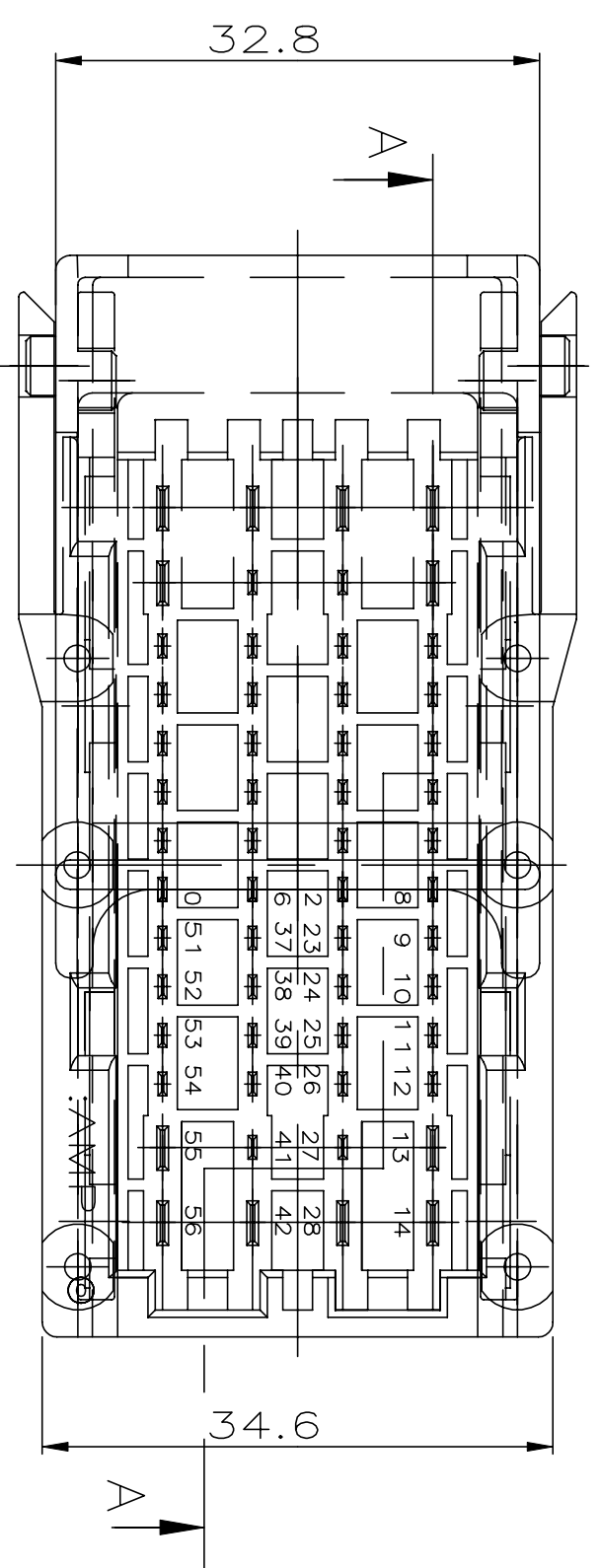
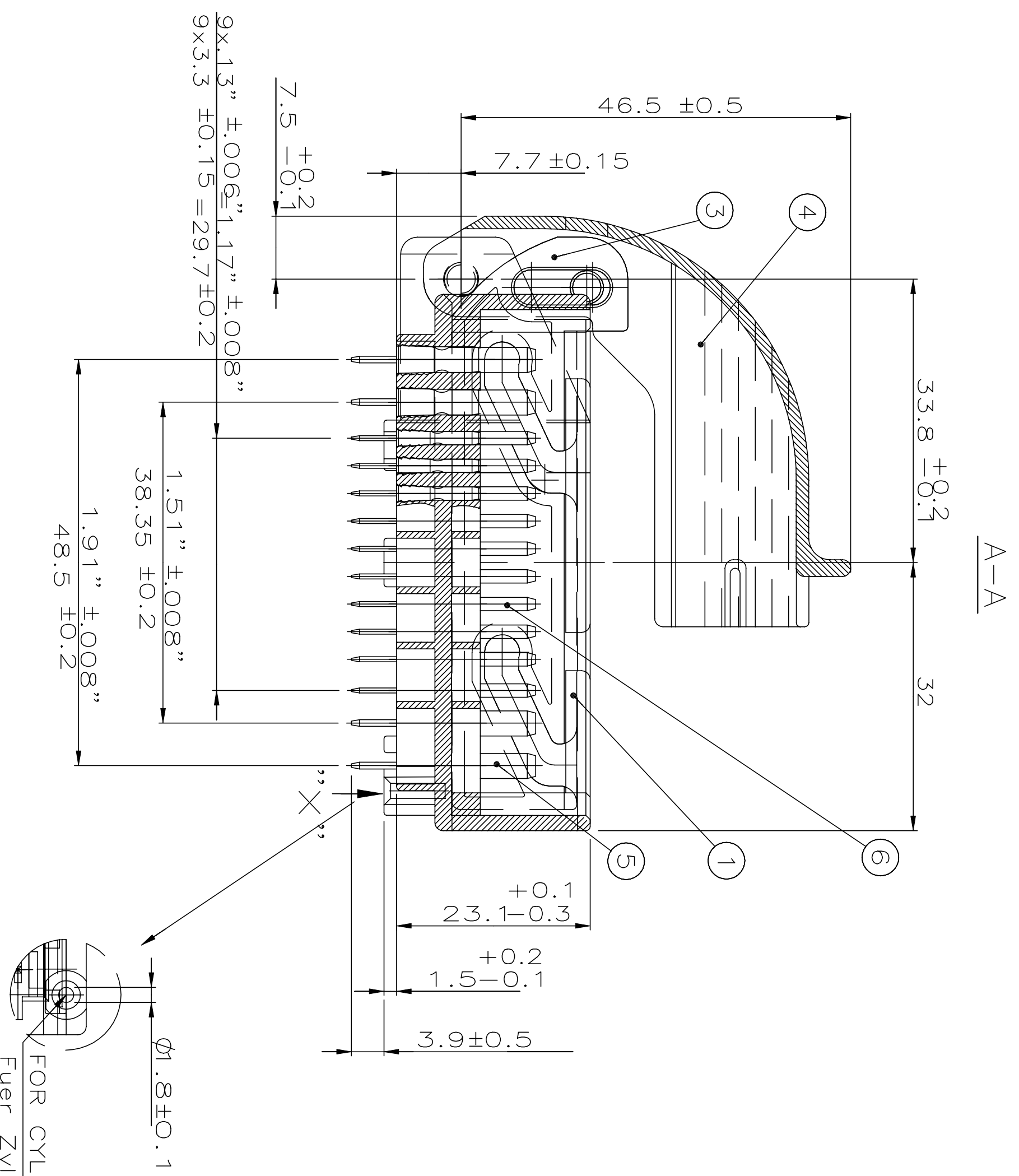

PARTS LIST SEE SHEET 2 OF 2

THIS DRAWING IS A CONTROLLED DOCUMENT.		DATE	21JUL1993
DRW	S.Garcia	APP	-
CHK	-	NAME	-
DIMENSIONS		UNIT	mm
OTHER INFORMATION		PROJ	-
MATERIAL		APPLIC	-
FINISH		WEIGHT	-
CUSTOMER DRAWING		SCALE	2:1
SHEET		1	2
REV		F1	F1

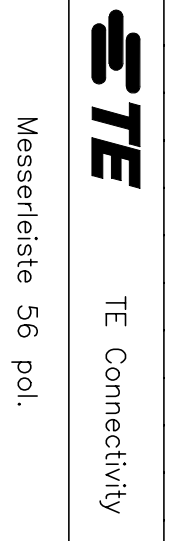

TE Connectivity
Messerleiste 56 pol.

SIZE CODE
A1 00779
DRAWING NO
963181
RESTRICTED TO

Kodierung A1

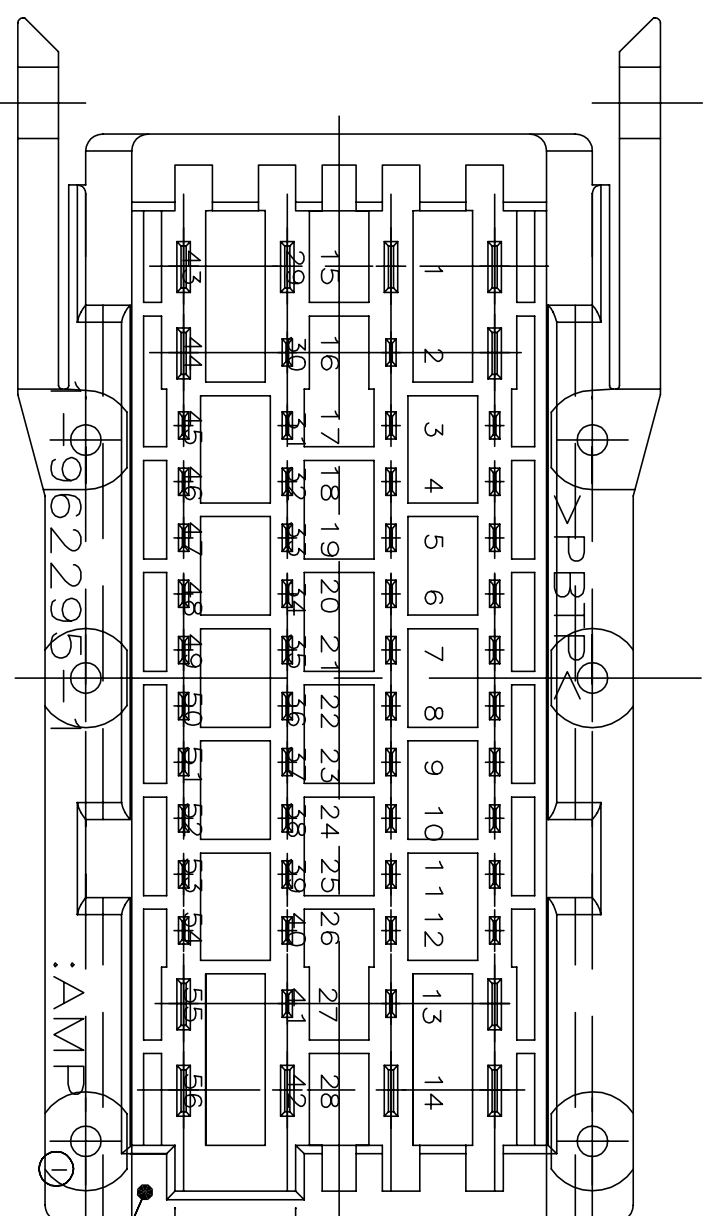

2.55 ± 0.2
9.65 ± 0.2

Kodierung D1

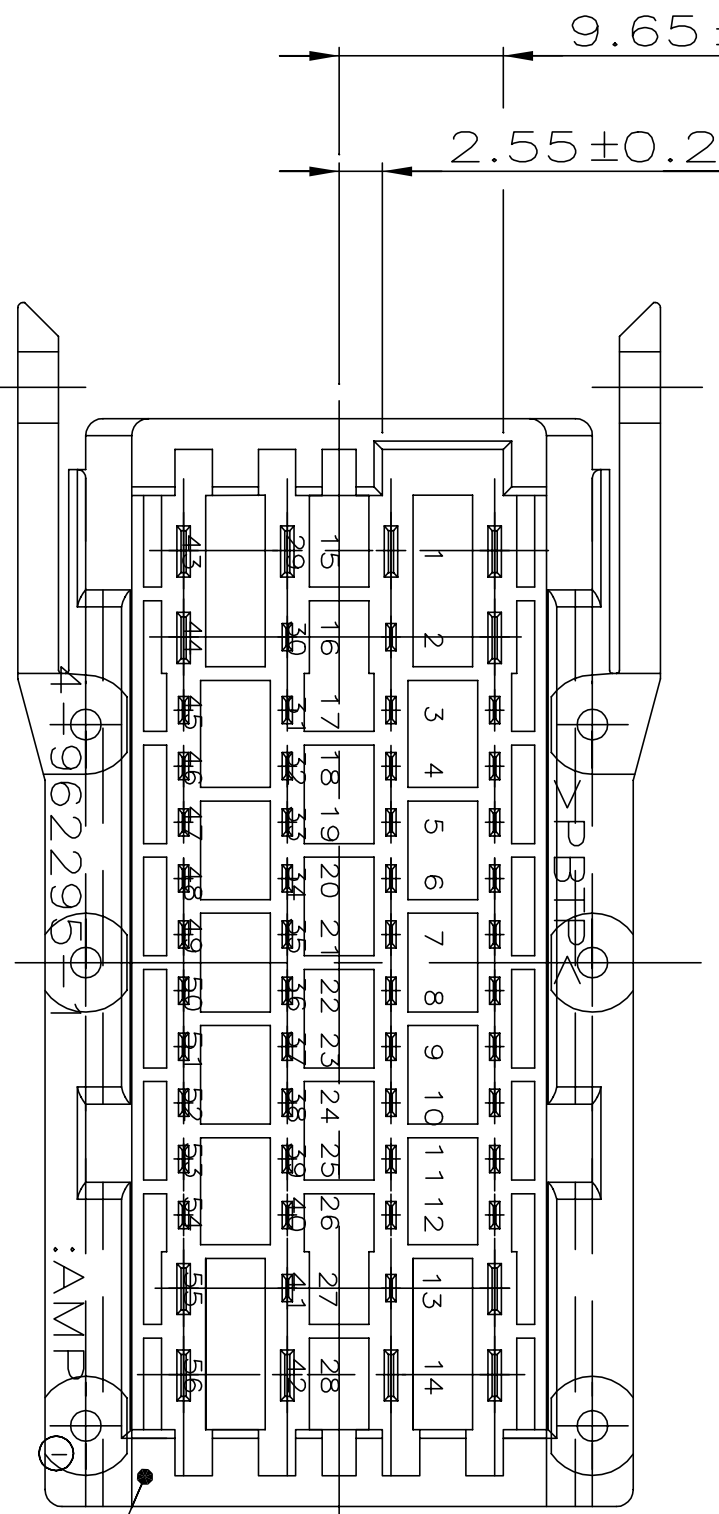

9.65 ± 0.2
2.55 ± 0.2

Kodierung B1

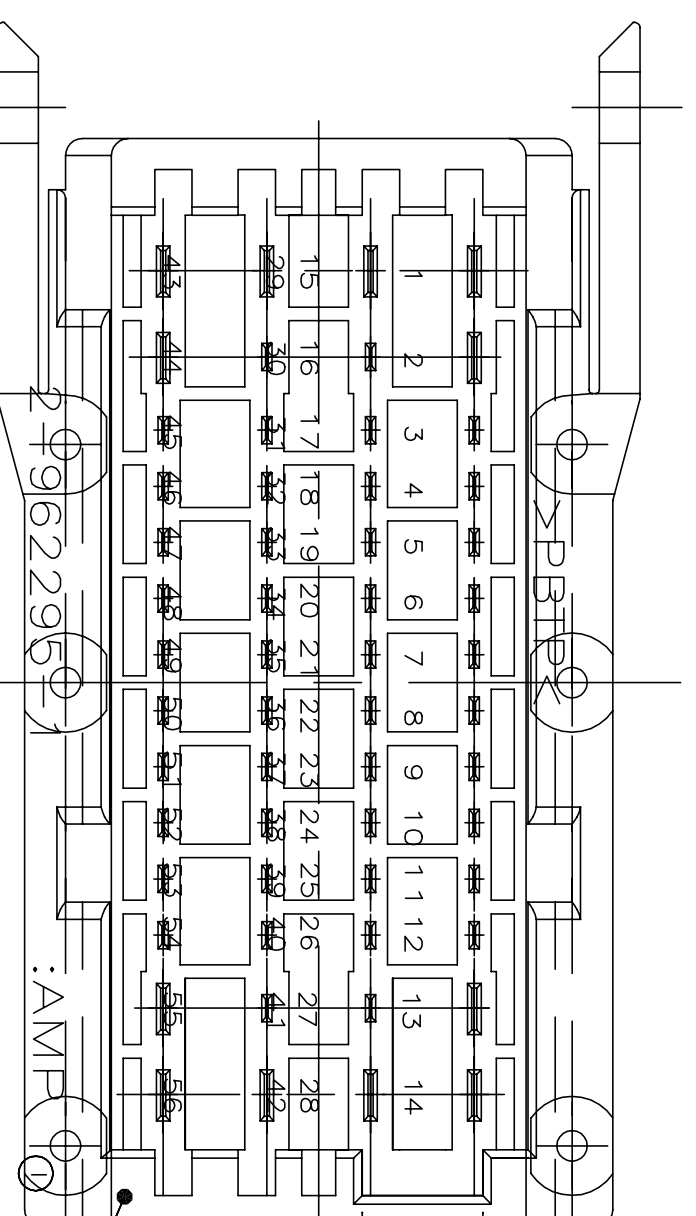

2.55 ± 0.2
9.65 ± 0.2

Kodierung N

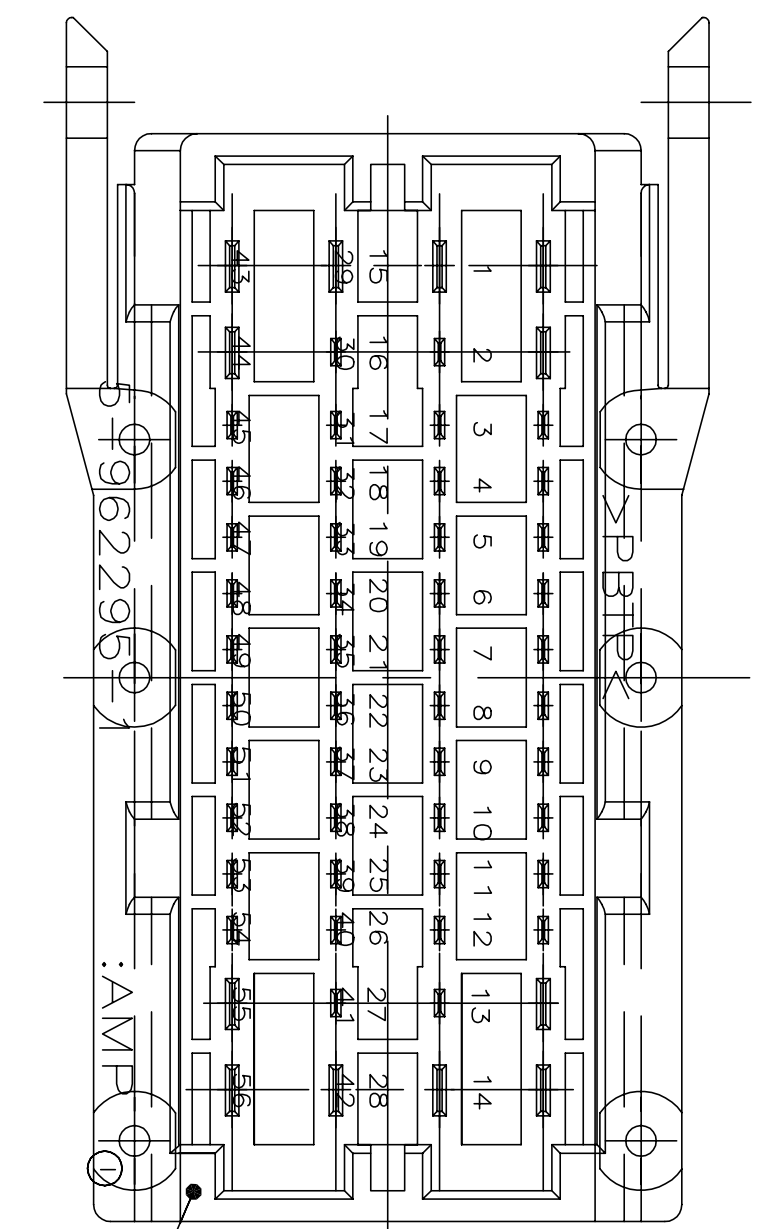
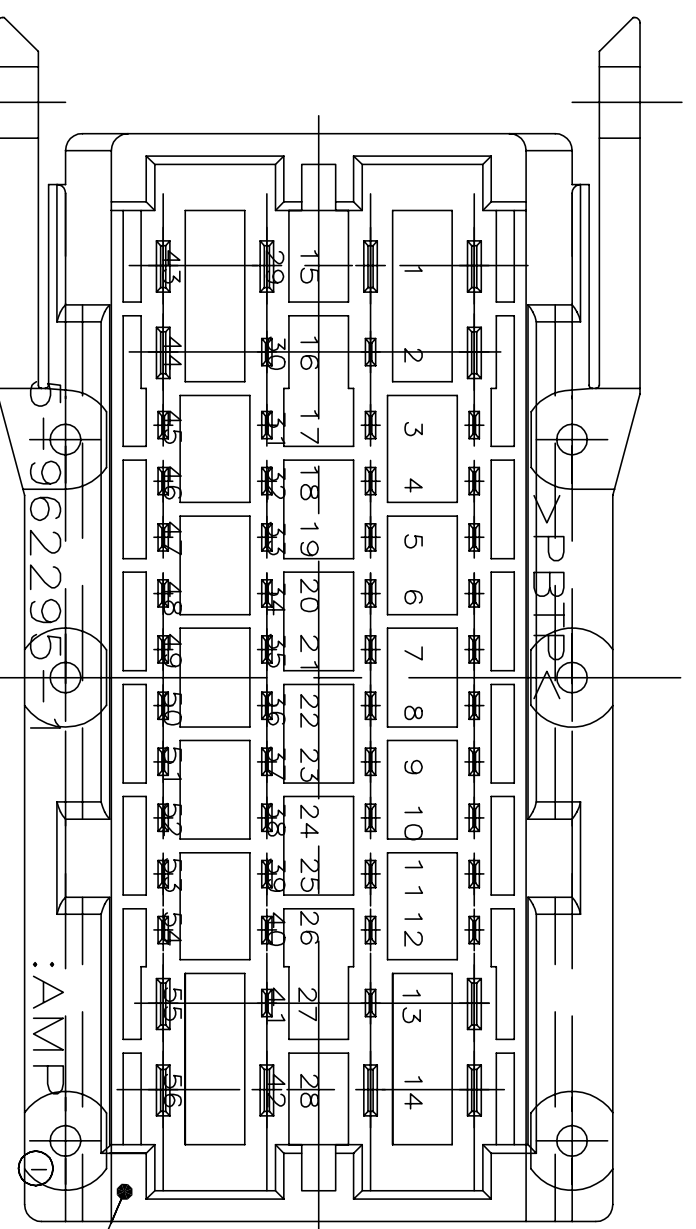

Kodierung C1

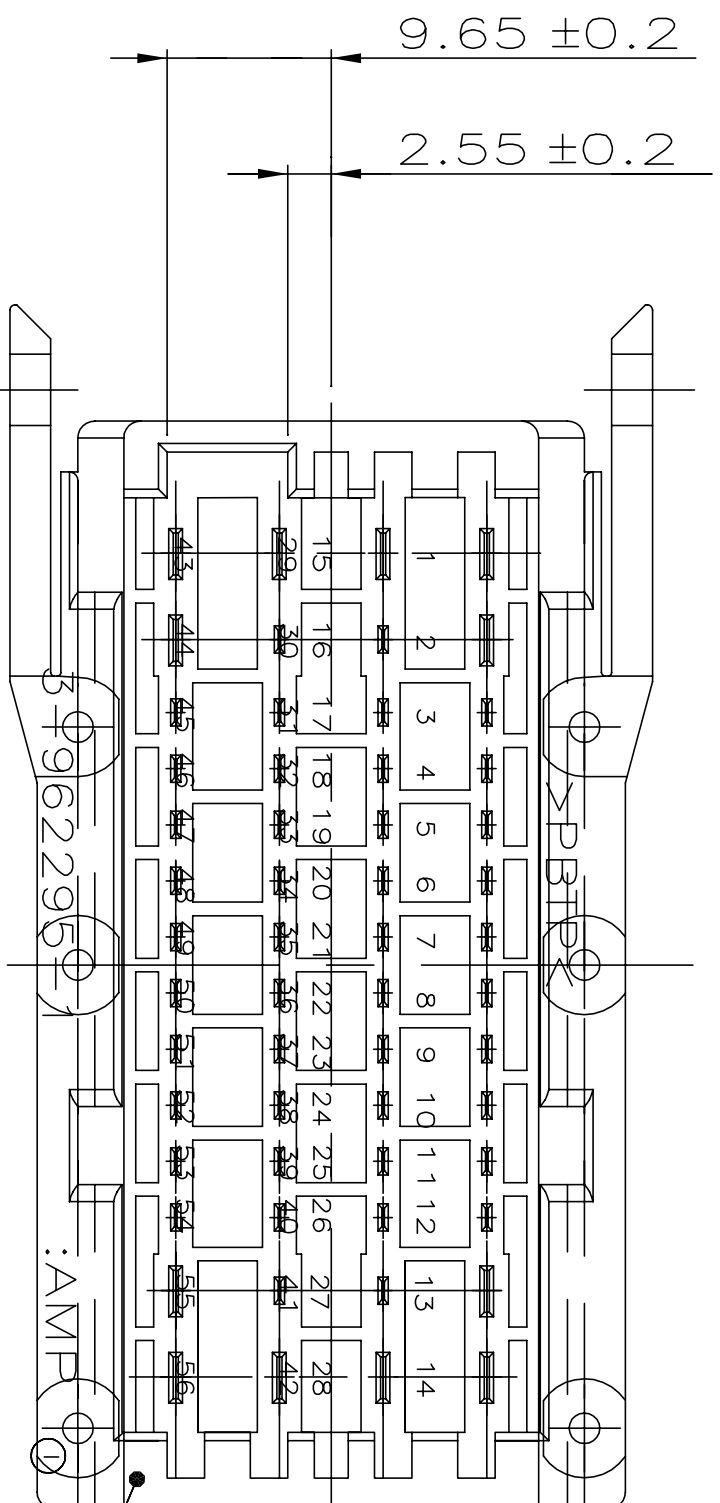

9.65 ± 0.2
2.55 ± 0.2

REVISIONS		DATE	DMT	BY
P	LR	21.04.1993	S.G.	-
C1	Neues Format war DIN A4	18.MAY.1995	I.S.	-
F	Abstandsrippen verbleibt			
F1	2-963181-1,3- -1,4- -1 and 5- -1 Pins are OBSOLETE	21.MAY.2021	J.H.	KP

F1

Kodierung	REV.	POS.	BENENNUNG EINZELTEIL	WERKSTOFF	WENKSTOFF
OBSOLETE					
Kodierung N		6	TAB 1.6	CUSn4	-
		5	TAB 2.8	CUSn4	-
		4	Buegel	PBT 20% GV	schwarz
		3	Schieber, links	PBT 20% GV	rot
		2	Schieber, rechts	PBT 20% GV	rot
		10	Messerleiste 56 pol.	PBT 20% GV	weiss
		6	TAB 1.6	CUSn4	-
		5	TAB 2.8	CUSn4	-
		4	Buegel	PBT 20% GV	schwarz
		3	Schieber, links	PBT 20% GV	rot
		2	Schieber, rechts	PBT 20% GV	rot
		9	Messerleiste 56 pol.	PBT 20% GV	braun
		6	TAB 1.6	CUSn4	-
		5	TAB 2.8	CUSn4	-
		4	Buegel	PBT 20% GV	schwarz
		3	Schieber, links	PBT 20% GV	rot
		2	Schieber, rechts	PBT 20% GV	rot
		8	Messerleiste 56 pol.	PBT 20% GV	blau
		6	TAB 1.6	CUSn4	-
		5	TAB 2.8	CUSn4	-
		4	Buegel	PBT 20% GV	schwarz
		3	Schieber, links	PBT 20% GV	rot
		2	Schieber, rechts	PBT 20% GV	rot
		8	Messerleiste 56 pol.	PBT 20% GV	blau
		6	TAB 1.6	CUSn4	-
		5	TAB 2.8	CUSn4	-
		4	Buegel	PBT 20% GV	schwarz
		3	Schieber, links	PBT 20% GV	rot
		2	Schieber, rechts	PBT 20% GV	rot
		7	Messerleiste 56 pol.	PBT 20% GV	grau
		6	TAB 1.6	CUSn4	-
		5	TAB 2.8	CUSn4	-
		4	Buegel	PBT 20% GV	schwarz
		3	Schieber, links	PBT 20% GV	rot
		2	Schieber, rechts	PBT 20% GV	rot
		1	Messerleiste 56 pol.	PBT 20% GV	schwarz
				PBT 20% GV	schwarz
				PBT 20% GV	rot
				PBT 20% GV	rot
				PBT 20% GV	schwarz
				PBT 20% GV	schwarz

THIS DRAWING IS A CONTROLLED DOCUMENT. 21.04.1993

CHANGES / REVISIONS

NO	DATE	BY	DESCRIPTION
1	21.04.1993	S. Garcia	

DIMENSIONS mm

FINISH

MATERIAL

SCALE 2.1

SHEET 1 of 2

REV F1

CUSTOMER DRAWING

STE TE Connectivity

Messerleiste 56 pol.

RESTRICTED TO

REVISIONS					
P	LTR	DESCRIPTION	DATE	DMN	APVD
C		963205-2 hinzu	23JAN1996	HS	-
C1		SEE PCN EG00-1133-03-1	27MAR2003	MAK	-
C2		963205-2 PN is OBSOLETE	23MAR2021	JJH	KP

1 CAVITY MARKING RAISED, OPTIONAL
 IN ONE OF THE WINDOWS
 Nestmarkierung erhaben, wahlweise
 in einem der Fenster

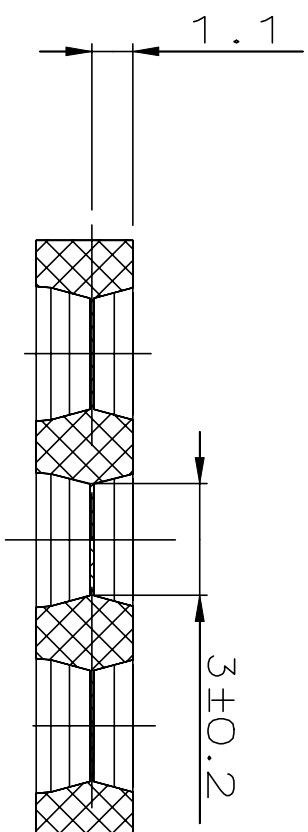
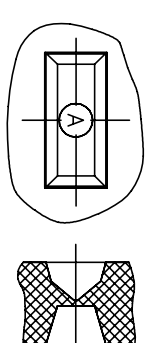

B-B

0.15 ± 0.1

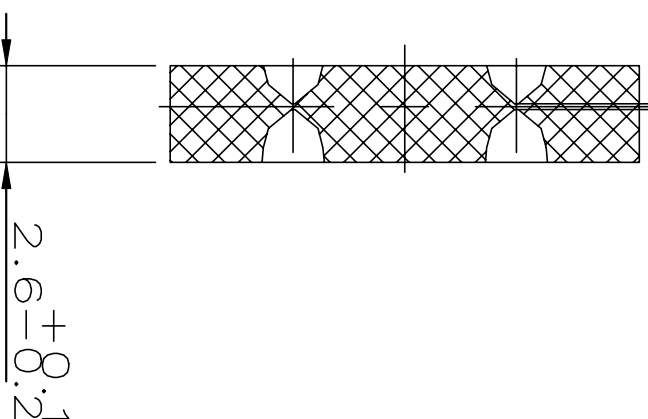

A-A

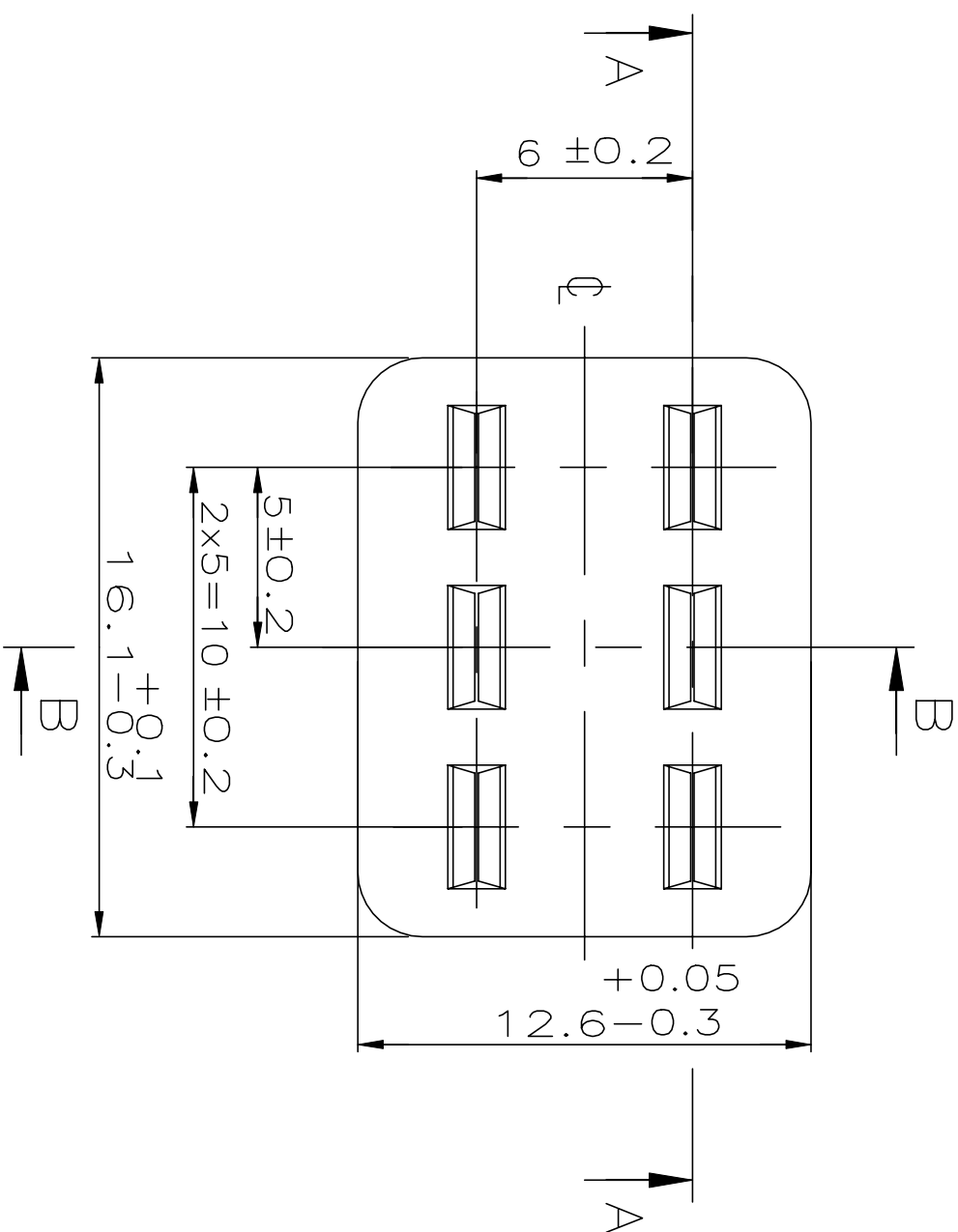

C2

gruen	Silicon	Dichtung, 6-polig	A	963205-2	2
natur	Silicon	Dichtung, 6-polig	C	963205-1	1
WERKSTOFF	BENENNUNG EINZELTEIL	REV	PART NO	ITEM NO	

THIS DRAWING IS A CONTROLLED DOCUMENT.		DMN	S. Garcia	014PR1993
DIMENSIONS: mm		CHK	W. Stobroth	014PR1993
TOLERANCES UNLESS OTHERWISE SPECIFIED:		APVD		
0 PLG	±	NAME		
1 PLG	±	Dichtung, 6-polig		
2 PLG	± 0.3mm			
3 PLG	±			
4 PLG	±			
ANGLES	±			
FINISH	±			

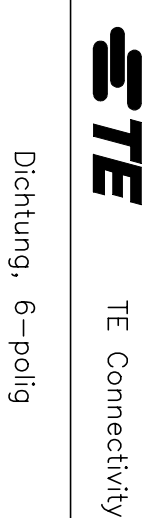

MATERIAL	SEE TABLE	WEIGHT	0.000000	SCALE	5:1	SHEET	1 of 1	REV	C2
CUSTOMER DRAWING		SIZE	A2	CAGE CODE	00779	DRAWING NO	963205	RESTRICTED TO	

REV	DATE	BY	CHKD	DESCRIPTION
2	21 MAY 1993	1-963449-2 FINIZU
D	15 OCT 1998	Změna umístění kontaktního NHT (konfigurační změna) - viz tabulka 1
D1	30 AUG 2007	SEE E-07-020683
D2	14 AUG 2016	REVISION OF 1-963449-1 AND 1-963449-2 IS CHANGED TO A
D3	23 MAR 2021	PN 1-963449-1 IS OBSOLETE

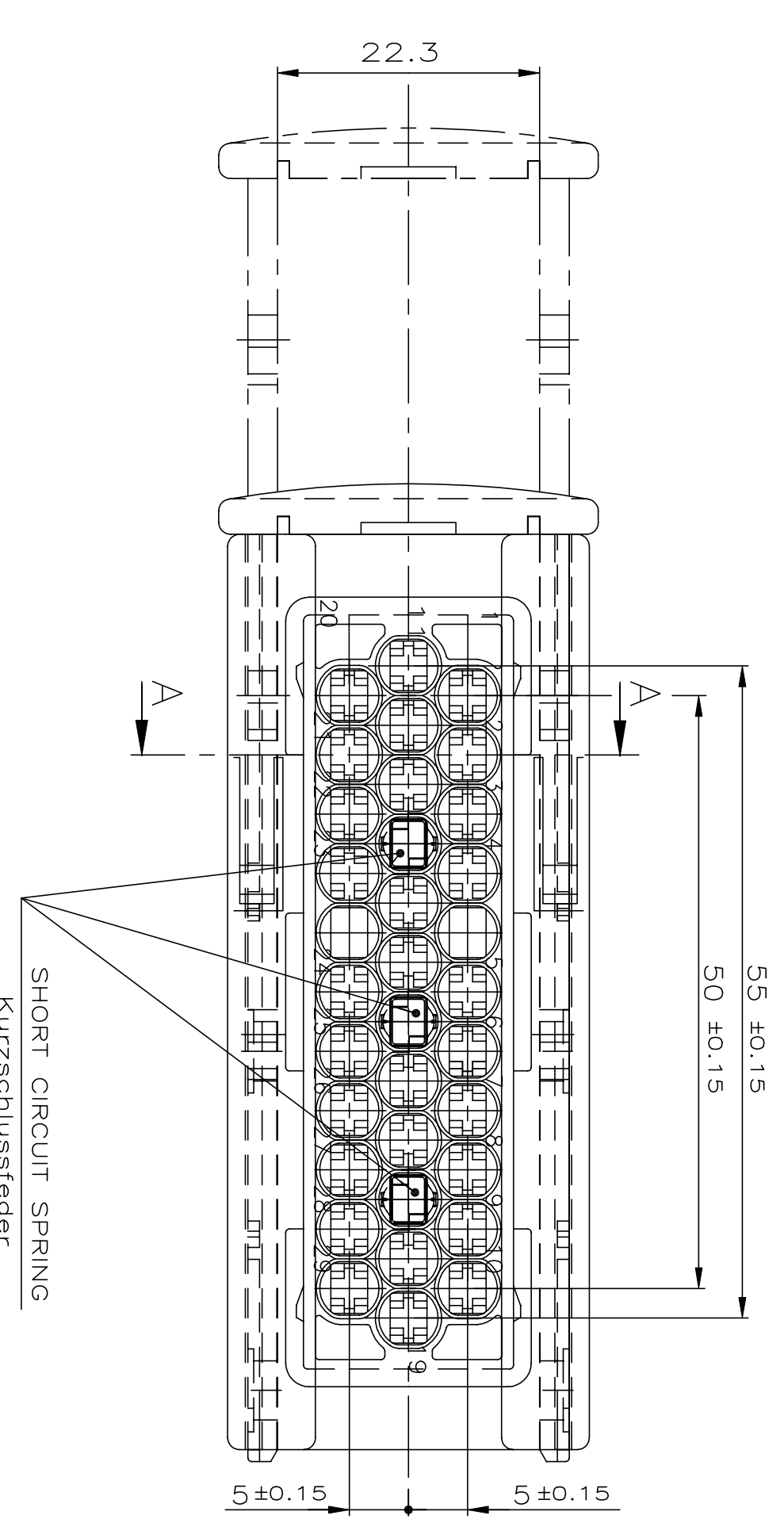
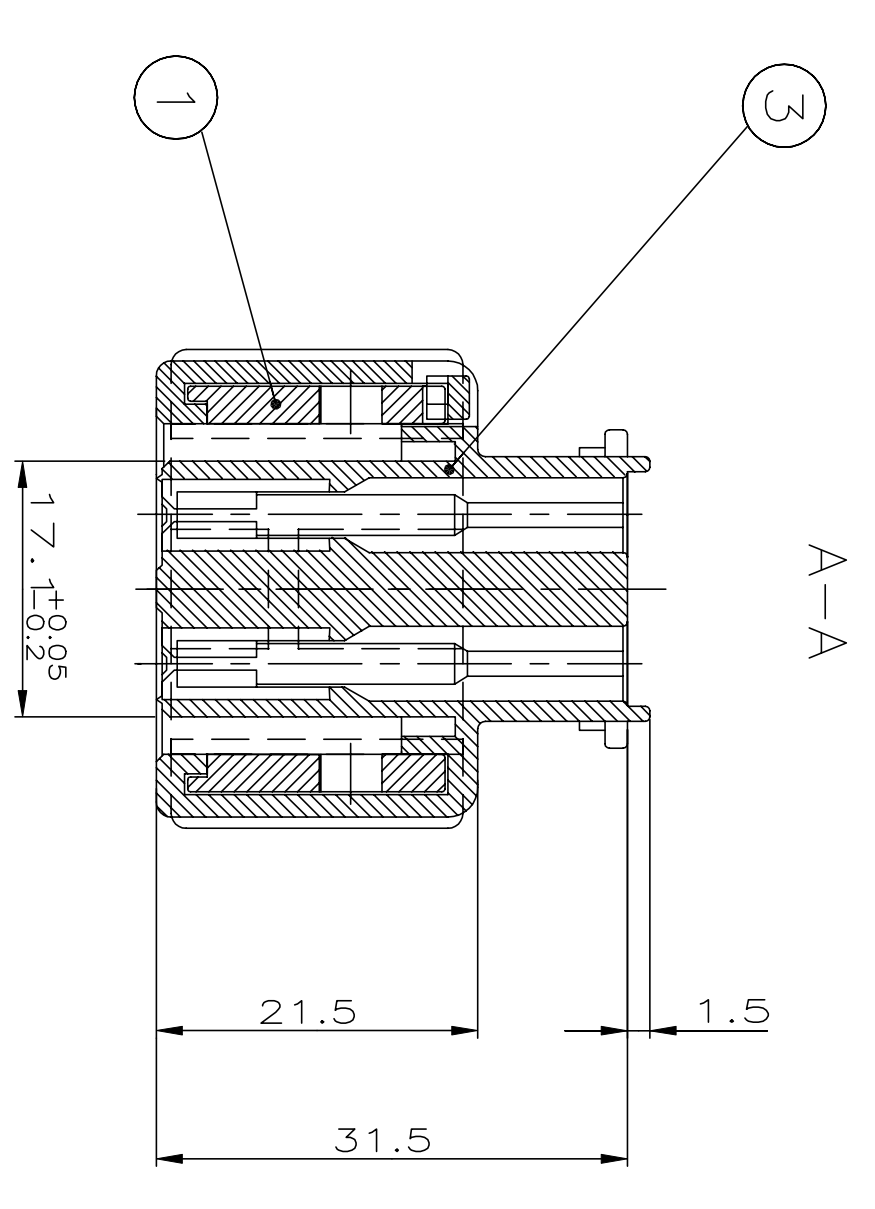
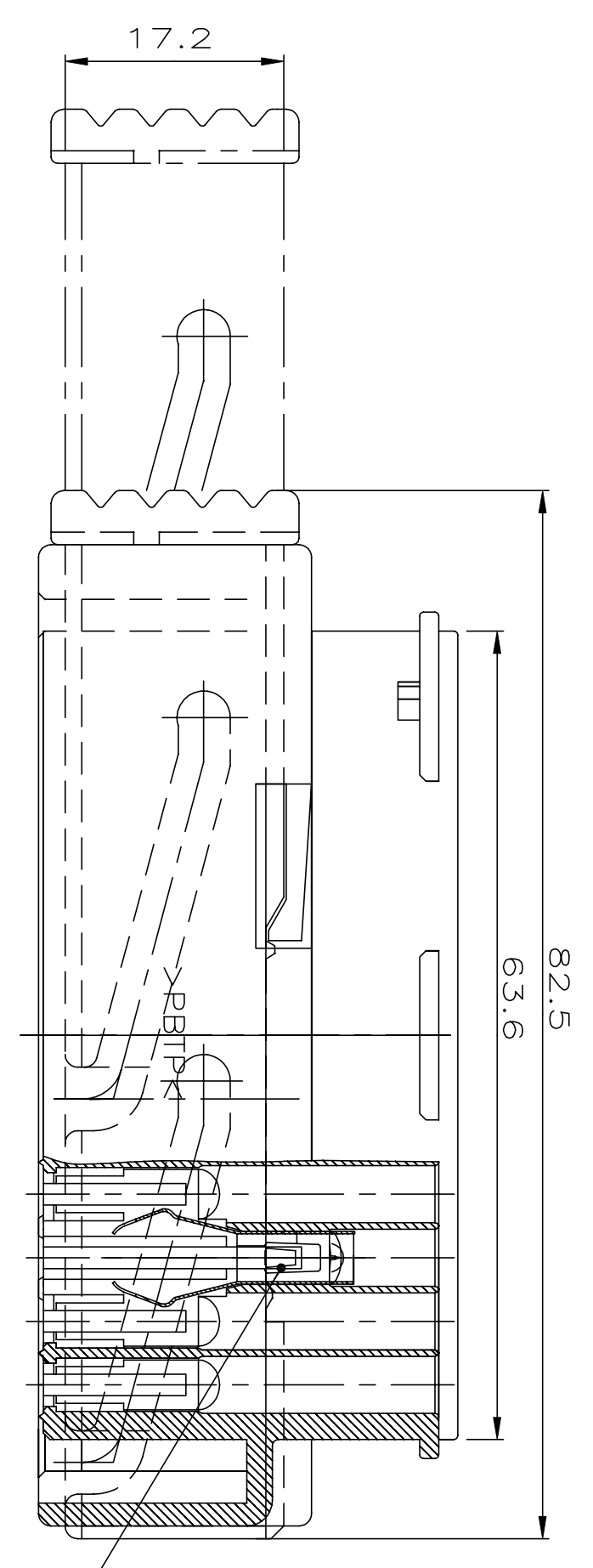
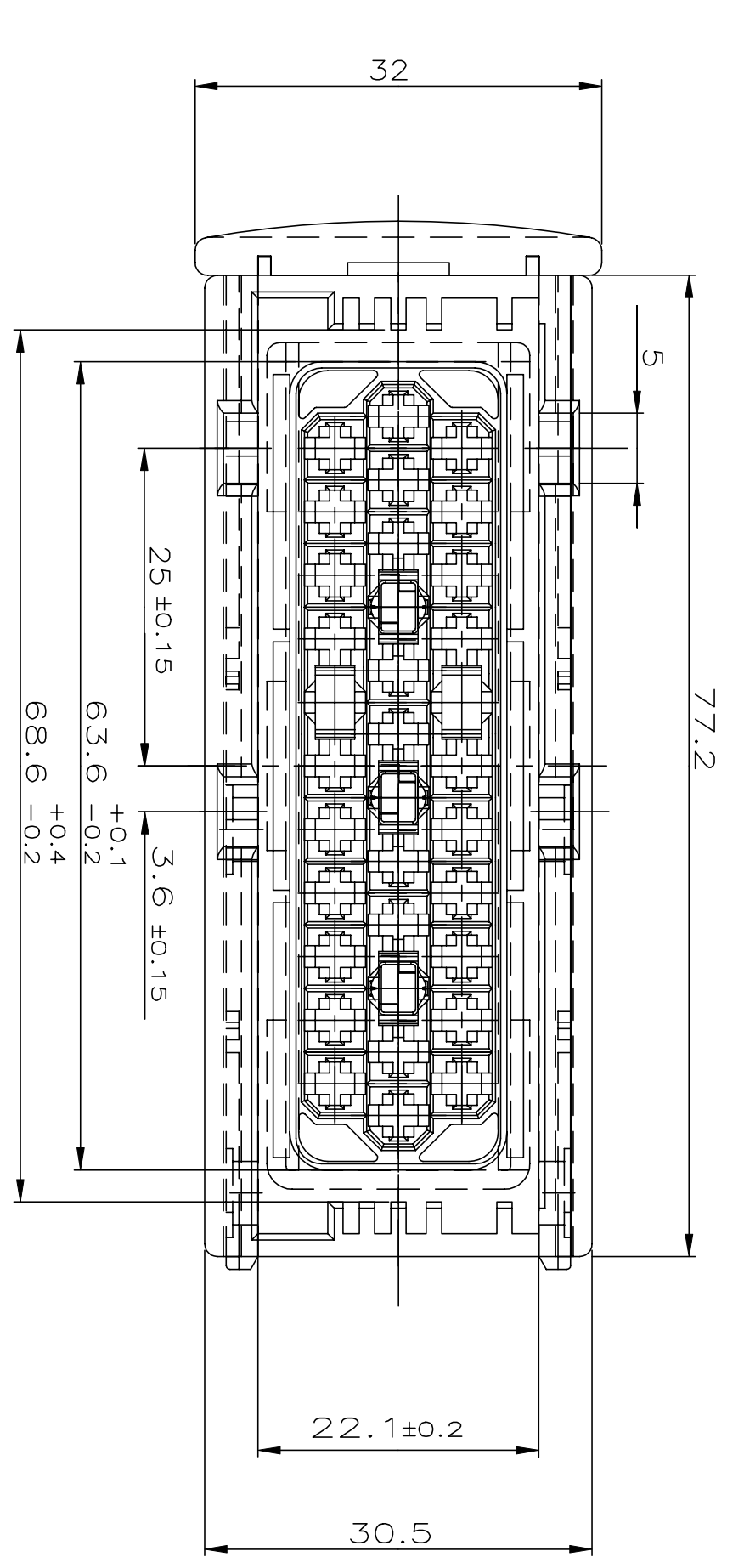

ENCODING	REV	POS	PCS	MATERIAL	SURFACE COLOR	DESCRIPTION	ITEM NO
ENCODING N 6-963449-1	A	3	1	PBT GV30	WHITE	JPT-HOUSING, 29POS JPT-Gehäuse, 29pol.	4
		1	1	PBT GV30	RED	SLIDE, 29POS Schleber, 29pol.	
		3	1	PBT GV30	RED	JPT-HOUSING, 29POS JPT-Gehäuse, 29pol.	
		1	1	PBT GV30	RED	SHORT CIRCUIT SPRING Kurzschlussfeder	
ENCODING B1 2-963449-1	A	3	1	PBT GV30	GREY	JPT-HOUSING, 29POS JPT-Gehäuse, 29pol.	3
		1	1	PBT GV30	RED	SLIDE, 29POS Schleber, 29pol.	
ENCODING A1 1-963449-1	A	3	1	PBT GV30	BLACK	JPT-HOUSING, 29POS JPT-Gehäuse, 29pol.	2
		1	1	PBT GV30	RED	SLIDE, 29POS Schleber, 29pol.	
		3	1	PBT GV30	RED	JPT-HOUSING, 29POS JPT-Gehäuse, 29pol.	
ENCODING A1 1-963449-1	A	2	3	X12 CMI 177	YELLOW	SHORT CIRCUIT SPRING Kurzschlussfeder	1
		1	1	PBT GV30	YELLOW	SLIDE, 29POS Schleber, 29pol.	
		1	1	PBT GV30	GOLD	SLIDE, 29POS Schleber, 29pol.	

1- -2 AS SHOWN
 wie gezeichnet

THIS DRAWING IS A CONTROLLED DOCUMENT.
 DIESE ZEICHNUNG IST EIN KONTROLLIERTES DOKUMENT.

DATE: 16-JUN-91
 BY: A. Hockl
 CHECKED: G. Bouda

PROJECT SPEC: JUNIOR POWER TIMER HSG, 29POS
 PRODUCT SPEC: Junior Power Timer Geh., 29pol.

SIZE: A1
 CODE: 00779
 DRAWING NO: 963449

RESTRICTED TO: JUNIOR

SCALE: 2:1
 SHEET: 1
 OF: 1
 REV: D3