

CD74AC138, CD74ACT138, CD74AC238, CD74ACT238

3-to-8-Line Decoders/Demultiplexers

Features

- CD74AC138, CD74ACT138 Inverting
- CD74AC238, CD74ACT238 Non-Inverting
- Buffered Inputs
- Typical Propagation Delay
 - 5ns at $V_{CC} = 5V$, $T_A = 25^\circ C$, $C_L = 50pF$
- Exceeds 2kV ESD Protection MIL-STD-883, Method 3015
- SCR-Latchup-Resistant CMOS Process and Circuit Design
- Speed of Bipolar FAST™/AS/S with Significantly Reduced Power Consumption
- Balanced Propagation Delays
- AC Types Feature 1.5V to 5.5V Operation and Balanced Noise Immunity at 30% of the Supply
- $\pm 24mA$ Output Drive Current
 - Fanout to 15 FAST™ ICs
 - Drives 50 Ω Transmission Lines

Pinout

CD74AC138, CD74ACT138, CD74AC238, CD74ACT238
 (PDIP, SOIC)
 TOP VIEW

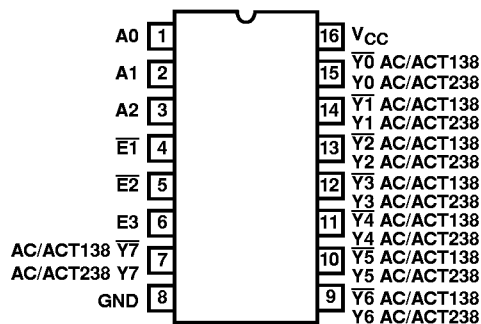

Description

The CD74AC138, CD74ACT138, CD74AC238, and CD74ACT238 are 3-to-8-line decoders/demultiplexers that utilize the Harris Advanced CMOS Logic technology. Both circuits have three binary select inputs (A0, A1, and A2). If the device is enabled, these inputs determine which one of the eight normally HIGH outputs of the AC/ACT138 will go LOW or which one of the normally LOW outputs of the AC/ACT238 will go HIGH. Two active LOW and one active HIGH enables ($\overline{E1}$, $\overline{E2}$ and E3) are provided to simplify the cascading of these devices.

Ordering Information

PART NUMBER	TEMP. RANGE ($^\circ C$)	PACKAGE	PKG. NO.
CD74AC138E	0 to 70 $^\circ C$, -40 to 85, -55 to 125	16 Ld PDIP	E16.3
CD74ACT138E	0 to 70 $^\circ C$, -40 to 85, -55 to 125	16 Ld PDIP	E16.3
CD74AC238E	0 to 70 $^\circ C$, -40 to 85, -55 to 125	16 Ld PDIP	E16.3
CD74ACT238E	0 to 70 $^\circ C$, -40 to 85, -55 to 125	16 Ld PDIP	E16.3
CD74AC138M	0 to 70 $^\circ C$, -40 to 85, -55 to 125	16 Ld SOIC	M16.15
CD74ACT138M	0 to 70 $^\circ C$, -40 to 85, -55 to 125	16 Ld SOIC	M16.15
CD74AC238M	0 to 70 $^\circ C$, -40 to 85, -55 to 125	16 Ld SOIC	M16.15
CD74ACT238M	0 to 70 $^\circ C$, -40 to 85, -55 to 125	16 Ld SOIC	M16.15

NOTES:

17. When ordering, use the entire part number. Add the suffix 96 to obtain the variant in the tape and reel.
18. Wafer and die for this part number is available which meets all electrical specifications. Please contact your local sales office or Harris customer service for ordering information.

CD74AC138, CD74ACT138, CD74AC238, CD74ACT238

Functional Diagram

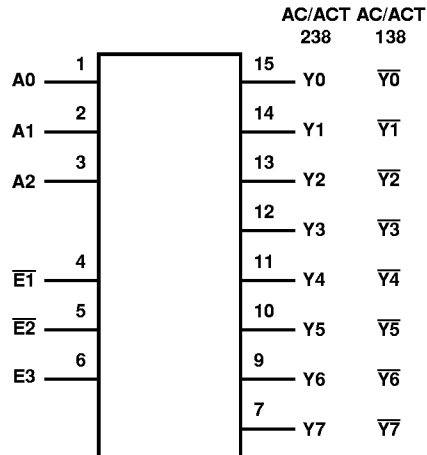

CD74AC/ACT138 TRUTH TABLE

INPUTS					OUTPUTS							
ENABLE		ADDRESS										
E_3	(NOTE 4) $\overline{E_0}$	A_2	A_1	A_0	$\overline{Y_0}$	$\overline{Y_1}$	$\overline{Y_2}$	$\overline{Y_3}$	$\overline{Y_4}$	$\overline{Y_5}$	$\overline{Y_6}$	$\overline{Y_7}$
X	H	X	X	X	H	H	H	H	H	H	H	H
L	X	X	X	X	H	H	H	H	H	H	H	H
H	L	L	L	L	L	H	H	H	H	H	H	H
H	L	L	L	H	H	L	H	H	H	H	H	H
H	L	L	H	L	H	H	L	H	H	H	H	H
H	L	L	H	H	H	H	H	L	H	H	H	H
H	L	H	L	L	H	H	H	H	L	H	H	H
H	L	H	L	L	H	H	H	H	H	L	H	H
H	L	H	H	L	H	H	H	H	H	H	L	H
H	L	H	H	H	H	H	H	H	H	H	H	L

CD74AC/ACT238 TRUTH TABLE

INPUTS					OUTPUTS							
ENABLE		ADDRESS										
E_3	(NOTE 4) $\overline{E_0}$	A_2	A_1	A_0	Y_0	Y_1	Y_2	Y_3	Y_4	Y_5	Y_6	Y_7
X	H	X	X	X	L	L	L	L	L	L	L	L
L	X	X	X	X	L	L	L	L	L	L	L	L
H	L	L	L	L	H	L	L	L	L	L	L	L
H	L	L	L	H	L	H	L	L	L	L	L	L
H	L	L	H	L	L	L	H	L	L	L	L	L
H	L	L	H	H	L	L	L	H	L	L	L	L
H	L	H	L	L	L	L	L	L	H	L	L	L
H	L	H	L	H	L	L	L	L	L	H	L	L
H	L	H	H	L	L	L	L	L	L	L	H	L
H	L	H	H	H	L	L	L	L	L	L	L	H

NOTES:

19. H = High Level, L = Low Level, X = Don't Care

20. $\overline{E_0} = \overline{E_1} + \overline{E_2}$

CD74AC138, CD74ACT138, CD74AC238, CD74ACT238

Absolute Maximum Ratings

DC Supply Voltage, V_{CC}	-0.5V to 6V
DC Input Diode Current, I_{IK}	
For $V_I < -0.5V$ or $V_I > V_{CC} + 0.5V$	$\pm 20mA$
DC Output Diode Current, I_{OK}	
For $V_O < -0.5V$ or $V_O > V_{CC} + 0.5V$	$\pm 50mA$
DC Output Source or Sink Current per Output Pin, I_O	
For $V_O > -0.5V$ or $V_O < V_{CC} + 0.5V$	$\pm 50mA$
DC V_{CC} or Ground Current, I_{CC} or I_{GND} (Note 5)	$\pm 100mA$

Thermal Information

Thermal Resistance (Typical, Note 7)	θ_{JA} (°C/W)
PDIP Package	90
SOIC Package	160
Maximum Junction Temperature (Plastic Package)	150°C
Maximum Storage Temperature Range	-65°C to 150°C
Maximum Lead Temperature (Soldering 10s)	300°C

Operating Conditions

Temperature Range, T_A	-55°C to 125°C
Supply Voltage Range, V_{CC} (Note 6)	
AC Types	1.5V to 5.5V
ACT Types	4.5V to 5.5V
DC Input or Output Voltage, V_I , V_O	0V to V_{CC}
Input Rise and Fall Slew Rate, dt/dv	
AC Types, 1.5V to 3V	50ns (Max)
AC Types, 3.6V to 5.5V	20ns (Max)
ACT Types, 4.5V to 5.5V	10ns (Max)

CAUTION: Stresses above those listed in "Absolute Maximum Ratings" may cause permanent damage to the device. This is a stress only rating and operation of the device at these or any other conditions above those indicated in the operational sections of this specification is not implied.

NOTES:

21. For up to 4 outputs per device, add $\pm 25mA$ for each additional output.
22. Unless otherwise specified, all voltages are referenced to ground.
23. θ_{JA} is measured with the component mounted on an evaluation PC board in free air.

DC Electrical Specifications

PARAMETER	SYMBOL	TEST CONDITIONS		V_{CC} (V)	25°C		-40°C TO 85°C		-55°C TO 125°C		UNITS	
		V_I (V)	I_O (mA)		MIN	MAX	MIN	MAX	MIN	MAX		
AC TYPES												
High Level Input Voltage	V_{IH}	-	-	1.5	1.2	-	1.2	-	1.2	-	V	
				3	2.1	-	2.1	-	2.1	-	V	
				5.5	3.85	-	3.85	-	3.85	-	V	
Low Level Input Voltage	V_{IL}	-	-	1.5	-	0.3	-	0.3	-	0.3	V	
				3	-	0.9	-	0.9	-	0.9	V	
				5.5	-	1.65	-	1.65	-	1.65	V	
High Level Output Voltage	V_{OH}	V_{IH} or V_{IL}	-0.05	-0.05	1.5	1.4	-	1.4	-	1.4	-	V
			-0.05	-0.05	3	2.9	-	2.9	-	2.9	-	V
			-0.05	-0.05	4.5	4.4	-	4.4	-	4.4	-	V
			-4	-4	3	2.58	-	2.48	-	2.4	-	V
			-24	-24	4.5	3.94	-	3.8	-	3.7	-	V
			-75 (Note 8, 9)	-75	5.5	-	-	3.85	-	-	-	V
			-50 (Note 8, 9)	-50	5.5	-	-	-	-	3.85	-	V

CD74AC138, CD74ACT138, CD74AC238, CD74ACT238

DC Electrical Specifications (Continued)

PARAMETER	SYMBOL	TEST CONDITIONS		V _{CC} (V)	25°C		-40°C TO 85°C		-55°C TO 125°C		UNITS		
		V _I (V)	I _O (mA)		MIN	MAX	MIN	MAX	MIN	MAX			
Low Level Output Voltage	V _{OL}	V _{IH} or V _{IL}	0.05	0.05	1.5	-	0.1	-	0.1	-	0.1	V	
			0.05	0.05	3	-	0.1	-	0.1	-	0.1	V	
			0.05	0.05	4.5	-	0.1	-	0.1	-	0.1	V	
			12	12	3	-	0.36	-	0.44	-	0.5	V	
			24	24	4.5	-	0.36	-	0.44	-	0.5	V	
			75 (Note 8, 9)	75 (Note 8, 9)	5.5	-	-	-	-	1.65	-	-	V
			50 (Note 8, 9)	50 (Note 8, 9)	5.5	-	-	-	-	-	-	1.65	V
Input Leakage Current	I _I	V _{CC} or GND	-	5.5	-	±0.1	-	±1	-	±1	µA		
Quiescent Supply Current MSI	I _{CC}	V _{CC} or GND	0	5.5	-	8	-	80	-	160	µA		
ACT TYPES													
High Level Input Voltage	V _{IH}	-	-	4.5 to 5.5	2	-	2	-	2	-	V		
Low Level Input Voltage	V _{IL}	-	-	4.5 to 5.5	-	0.8	-	0.8	-	0.8	V		
High Level Output Voltage	V _{OH}	V _{IH} or V _{IL}	-0.05	-0.05	4.5	4.4	-	4.4	-	4.4	-	V	
			-24	-24	4.5	3.94	-	3.8	-	3.7	-	V	
			-75 (Note 8, 9)	-75 (Note 8, 9)	5.5	-	-	-	3.85	-	-	-	V
			-50 (Note 8, 9)	-50 (Note 8, 9)	5.5	-	-	-	-	-	3.85	-	V
Low Level Output Voltage	V _{OL}	V _{IH} or V _{IL}	0.05	0.05	4.5	-	0.1	-	0.1	-	0.1	V	
			24	24	4.5	-	0.36	-	0.44	-	0.5	V	
			75 (Note 8, 9)	75 (Note 8, 9)	5.5	-	-	-	1.65	-	-	V	
			50 (Note 8, 9)	50 (Note 8, 9)	5.5	-	-	-	-	-	1.65	V	
Input Leakage Current	I _I	V _{CC} or GND	-	5.5	-	±0.1	-	±1	-	±1	µA		
Quiescent Supply Current MSI	I _{CC}	V _{CC} or GND	0	5.5	-	8	-	80	-	160	µA		
Additional Supply Current per Input Pin TTL Inputs High 1 Unit Load	ΔI _{CC}	V _{CC} -2.1	-	4.5 to 5.5	-	2.4	-	2.8	-	3	mA		

NOTES:

- 24. Test one output at a time for a 1-second maximum duration. Measurement is made by forcing current and measuring voltage to minimize power dissipation.
- 25. Test verifies a minimum 50Ω transmission-line-drive capability at 85°C, 75Ω at 125°C.

ACT Input Load Table

INPUT	UNIT LOAD
A0-A2	0.83
E1, E2	1
E3	0.42

NOTE: Unit load is ΔI_{CC} limit specified in DC Electrical Specifications Table, e.g., 2.4mA max at 25°C.

CD74AC138, CD74ACT138, CD74AC238, CD74ACT238

Switching Specifications Input $t_r, t_f = 3\text{ns}$, $C_L = 50\text{pF}$ (Worst Case)

PARAMETER	SYMBOL	V _{CC} (V)	-40°C TO 85°C			-55°C TO 125°C			UNITS
			MIN	TYP	MAX	MIN	TYP	MAX	
AC TYPES									
Propagation Delay, An to Output (CD74AC/ACT138)	t_{PLH}, t_{PHL}	1.5	-	-	125	-	-	138	ns
		3.3 (Note 11)	4	-	14	3.9	-	15.4	ns
		5 (Note 12)	2.8	-	10	2.8	-	11	ns
Propagation Delay, $\overline{E1}, \overline{E2}$ to Output (CD74AC/ACT138)	t_{PLH}, t_{PHL}	1.5	-	-	114	-	-	125	ns
		3.3	3.6	-	12.7	3.5	-	14	ns
		5	2.6	-	9.1	2.5	-	10	ns
Propagation Delay, E3 to Output (CD74AC/ACT138)	t_{PLH}, t_{PHL}	1.5	-	-	125	-	-	138	ns
		3.3	4	-	14	3.9	-	15.4	ns
		5	2.8	-	10	2.8	-	11	ns
Propagation Delay, An to Output (CD74AC/ACT238)	t_{PLH}, t_{PHL}	1.5	-	-	170	-	-	187	ns
		3.3	5.4	-	19.1	5.3	-	21	ns
		5	3.9	-	13.6	3.8	-	15	ns
Propagation Delay, $\overline{E1}, \overline{E2}$ to Output (CD74AC/ACT238)	t_{PLH}, t_{PHL}	1.5	-	-	135	-	-	149	ns
		3.3	4.3	-	15.2	4.2	-	16.7	ns
		5	3.1	-	10.7	3	-	11.9	ns
Propagation Delay, E3 to Output (CD74AC/ACT238)	t_{PLH}, t_{PHL}	1.5	-	-	189	-	-	208	ns
		3.3	6	-	21.1	5.8	-	23.2	ns
		5	4.3	-	15.1	4.2	-	16.6	ns
Input Capacitance	C_I	-	-	-	10	-	-	10	pF
Power Dissipation Capacitance	C_{PD} (Note 13)	-	-	110	-	-	110	-	pF
ACT TYPES									
Propagation Delay, An to Output (CD74AC/ACT138)	t_{PLH}, t_{PHL}	5 (Note 12)	3.1	-	10.9	3	-	12	ns
Propagation Delay, $\overline{E1}, \overline{E2}$ to Output (CD74AC/ACT138)	t_{PLH}, t_{PHL}	5	2.7	-	9.5	2.6	-	10.5	ns
Propagation Delay, E3 to Output (CD74AC/ACT138)	t_{PLH}, t_{PHL}	5	2.8	-	10	2.8	-	11	ns
Propagation Delay, An to Output (CD74AC/ACT238)	t_{PLH}, t_{PHL}	5	4	-	14.2	3.9	-	15.6	ns
Propagation Delay, $\overline{E1}, \overline{E2}$ to Output (CD74AC/ACT238)	t_{PLH}, t_{PHL}	5	3.7	-	12.9	3.6	-	14.2	ns

CD74AC138, CD74ACT138, CD74AC238, CD74ACT238

Switching Specifications Input $t_r, t_f = 3\text{ns}$, $C_L = 50\text{pF}$ (Worst Case) (Continued)

PARAMETER	SYMBOL	V_{CC} (V)	-40°C TO 85°C			-55°C TO 125°C			UNITS
			MIN	TYP	MAX	MIN	TYP	MAX	
Propagation Delay, E3 to Output (CD74AC/ACT238)	t_{PLH}, t_{PHL}	5	3.5	-	12.4	3.4	-	13.6	ns
Input Capacitance	C_I	-	-	-	10	-	-	10	pF
Power Dissipation Capacitance	C_{PD} (Note 13)	-	-	110	-	-	110	-	pF

NOTES:

26. Limits tested at 100%.
27. 3.3V Min at 3.6V, Max at 3V.
28. 5V Min at 5.5V, Max at 4.5V.
29. C_{PD} is used to determine the dynamic power consumption per package.
 AC: $P_D = V_{CC}^2 f_i (C_{PD} + C_L)$
 ACT: $P_D = V_{CC}^2 f_i (C_{PD} + C_L) + V_{CC} \Delta I_{CC}$ where f_i = input frequency, C_L = output load capacitance, V_{CC} = supply voltage.

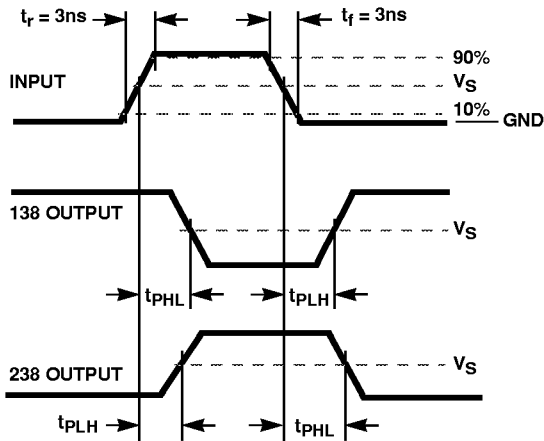

FIGURE 8. PROPAGATION DELAY TIMES

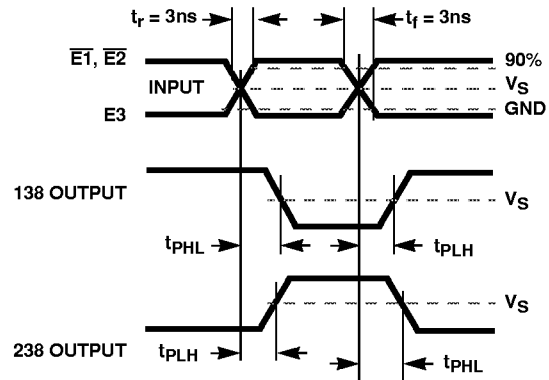
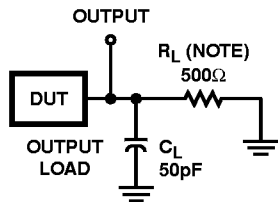

FIGURE 9. PROPAGATION DELAY TIMES



NOTE: For AC Series Only: When $V_{CC} = 1.5\text{V}$, $R_L = 1\text{k}\Omega$.

	CD74AC	CD74ACT
Input Level	V_{CC}	3V
Input Switching Voltage, V_S	$0.5 V_{CC}$	1.5V
Output Switching Voltage, V_S	$0.5 V_{CC}$	$0.5 V_{CC}$

FIGURE 10. PROPAGATION DELAY TIMES

IMPORTANT NOTICE

Texas Instruments and its subsidiaries (TI) reserve the right to make changes to their products or to discontinue any product or service without notice, and advise customers to obtain the latest version of relevant information to verify, before placing orders, that information being relied on is current and complete. All products are sold subject to the terms and conditions of sale supplied at the time of order acknowledgement, including those pertaining to warranty, patent infringement, and limitation of liability.

TI warrants performance of its semiconductor products to the specifications applicable at the time of sale in accordance with TI's standard warranty. Testing and other quality control techniques are utilized to the extent TI deems necessary to support this warranty. Specific testing of all parameters of each device is not necessarily performed, except those mandated by government requirements.

CERTAIN APPLICATIONS USING SEMICONDUCTOR PRODUCTS MAY INVOLVE POTENTIAL RISKS OF DEATH, PERSONAL INJURY, OR SEVERE PROPERTY OR ENVIRONMENTAL DAMAGE ("CRITICAL APPLICATIONS"). TI SEMICONDUCTOR PRODUCTS ARE NOT DESIGNED, AUTHORIZED, OR WARRANTED TO BE SUITABLE FOR USE IN LIFE-SUPPORT DEVICES OR SYSTEMS OR OTHER CRITICAL APPLICATIONS. INCLUSION OF TI PRODUCTS IN SUCH APPLICATIONS IS UNDERSTOOD TO BE FULLY AT THE CUSTOMER'S RISK.

In order to minimize risks associated with the customer's applications, adequate design and operating safeguards must be provided by the customer to minimize inherent or procedural hazards.

TI assumes no liability for applications assistance or customer product design. TI does not warrant or represent that any license, either express or implied, is granted under any patent right, copyright, mask work right, or other intellectual property right of TI covering or relating to any combination, machine, or process in which such semiconductor products or services might be or are used. TI's publication of information regarding any third party's products or services does not constitute TI's approval, warranty or endorsement thereof.