

54ACT11138, 74ACT11138 3-LINE TO 8-LINE DECODERS/DEMULTIPLEXERS

SCAS050A – D3266, JANUARY 1989 – REVISED APRIL 1993

- Designed Specifically for High-Speed Memory Decoders and Data Transmission Systems
- Incorporates Three Enable Inputs to Simplify Cascading and/or Data Reception
- Flow-Through Architecture Optimizes PCB Layout
- Center-Pin V_{CC} and GND Configurations Minimize High-Speed Switching Noise
- EPIC™ (Enhanced-Performance Implanted CMOS) 1- μ m Process
- 650-mA Typical Latch-Up Immunity at 125°C
- Package Options Include Plastic Small-Outline Packages, Plastic Thin Shrink Small-Outline Packages, Ceramic Chip Carriers, and Standard Plastic and Ceramic 300-mil DIPs

description

The 'ACT11138 circuit is designed to be used in high-performance memory-decoding or data-routing applications requiring very short propagation delay times. In high-performance memory systems, this decoder can be used to minimize the effects of system decoding. When employed with high-speed memories utilizing a fast enable circuit, the delay times of this decoder and the enable time of the memory are usually less than the typical access time of the memory. This means that the effective system delay introduced by the decoder is negligible.

The conditions at the binary select inputs and the three enable inputs select one of eight input lines. Two active-low and one active-high enable inputs reduce the need for external gates or inverters when expanding. A 24-line decoder can be implemented without external inverters and a 32-line decoder requires only one inverter. An enable input can be used as a data input for demultiplexing applications.

The 54ACT11138 is characterized for operation over the full military temperature range of – 55°C to 125°C. The 74ACT11138 is characterized for operation from – 40°C to 85°C.

54ACT11138 ... J PACKAGE
74ACT11138 ... D, N, OR PW PACKAGE

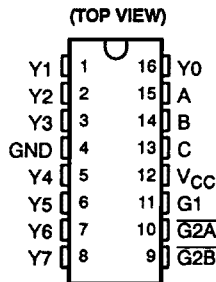

54ACT11138 ... FK PACKAGE
(TOP VIEW)

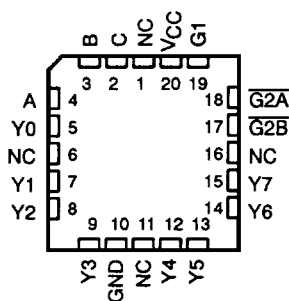

NC – No internal connection

EPIC is a trademark of Texas Instruments Incorporated.

PRODUCTION DATA information is current as of publication date. Products conform to specifications per the terms of Texas Instruments standard warranty. Production processing does not necessarily include testing of all parameters.

TEXAS
INSTRUMENTS

POST OFFICE BOX 655303 • DALLAS, TEXAS 75265

Copyright © 1993, Texas Instruments Incorporated

2-161

54ACT11138, 74ACT11138 3-LINE TO 8-LINE DECODERS/DEMULTIPLEXERS

SCAS050A - D3266, JANUARY 1989 - REVISED APRIL 1993

logic symbols (alternatives)[†]

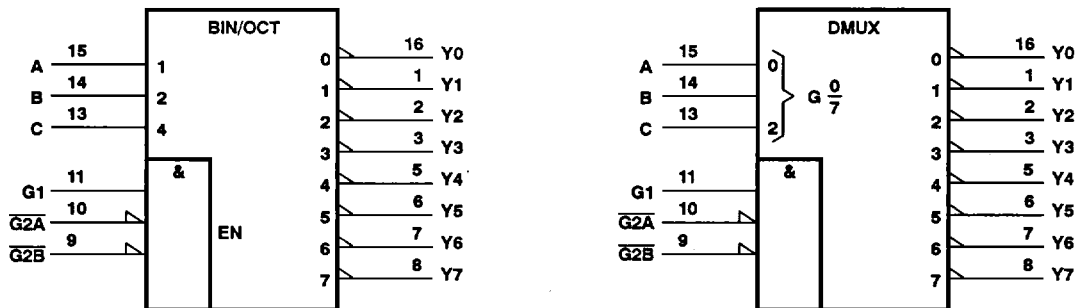

[†] These symbols are in accordance with ANSI/IEEE Std 91-1984 and IEC Publication 617-12. Pin numbers shown are for the D, J, and N packages.

logic diagram (positive logic)

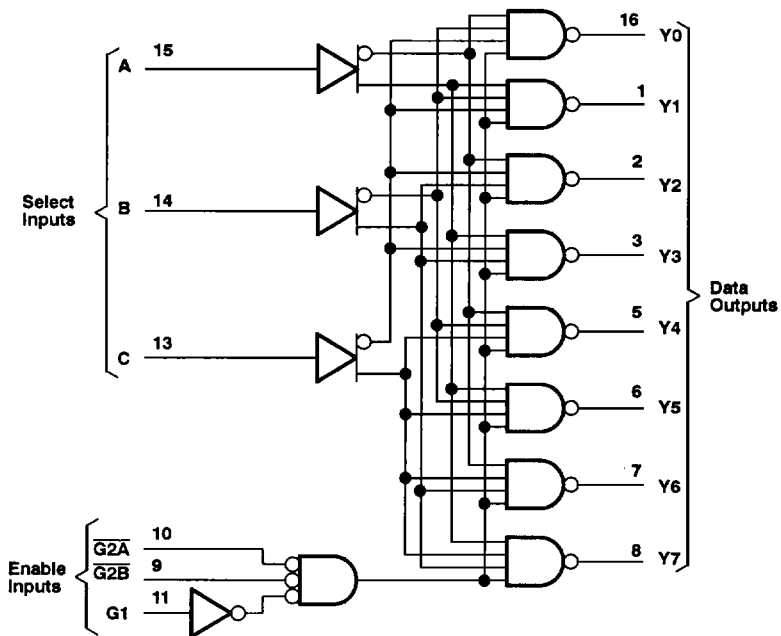

Pin numbers shown are for the D, J, and N packages.

TEXAS
INSTRUMENTS

POST OFFICE BOX 655303 • DALLAS, TEXAS 75265

54ACT11138, 74ACT11138 3-LINE TO 8-LINE DECODERS/DEMULTIPLEXERS

SCAS050A – D3266, JANUARY 1989 – REVISED APRIL 1993

FUNCTION TABLE

ENABLE INPUTS			SELECT INPUTS			OUTPUTS							
G1	G2A	G2B	C	B	A	Y0	Y1	Y2	Y3	Y4	Y5	Y6	Y7
X	H	X	X	X	X	H	H	H	H	H	H	H	H
X	X	H	X	X	X	H	H	H	H	H	H	H	H
L	X	X	X	X	X	H	H	H	H	H	H	H	H
H	L	L	L	L	L	L	H	H	H	H	H	H	H
H	L	L	L	L	H	H	L	H	H	H	H	H	H
H	L	L	L	H	L	H	H	L	H	H	H	H	H
H	L	L	L	H	H	H	H	H	L	H	H	H	H
H	L	L	H	L	L	H	H	H	H	L	H	H	H
H	L	L	H	L	H	H	H	H	H	H	L	H	H
H	L	L	H	H	L	H	H	H	H	H	H	L	H
H	L	L	H	H	H	H	H	H	H	H	H	H	L

absolute maximum ratings over operating free-air temperature range (unless otherwise noted)†

Supply voltage range, V_{CC}	–0.5 V to 7 V
Input voltage range, V_I (see Note 1)	–0.5 V to $V_{CC} + 0.5$ V
Output voltage range, V_O (see Note 1)	–0.5 V to $V_{CC} + 0.5$ V
Input clamp current, I_{IK} ($V_I < 0$ or $V_I > V_{CC}$)	± 20 mA
Output clamp current, I_{OK} ($V_O < 0$ or $V_O > V_{CC}$)	± 50 mA
Continuous output current, I_O ($V_O = 0$ to V_{CC})	± 50 mA
Continuous current through V_{CC} or GND	± 200 mA
Storage temperature range	–65°C to 150°C

† Stresses beyond those listed under "absolute maximum ratings" may cause permanent damage to the device. These are stress ratings only and functional operation of the device at these or any other conditions beyond those indicated under "recommended operating conditions" is not implied. Exposure to absolute-maximum-rated conditions for extended periods may affect device reliability.

NOTE 1: The input and output voltage ratings may be exceeded if the input and output current ratings are observed.

recommended operating conditions

		54ACT11138		74ACT11138		UNIT
		MIN	MAX	MIN	MAX	
V_{CC}	Supply voltage	4.5	5.5	4.5	5.5	V
V_{IH}	High-level input voltage	2		2		V
V_{IL}	Low-level input voltage		0.8		0.8	V
V_I	Input voltage	0	V_{CC}	0	V_{CC}	V
V_O	Output voltage	0	V_{CC}	0	V_{CC}	V
I_{OH}	High-level output current		–24		–24	mA
I_{OL}	Low-level output current		24		24	mA
$\Delta t/\Delta v$	Input transition rise or fall rate	0	10	0	10	ns/V
T_A	Operating free-air temperature	–55	125	–40	85	°C

54ACT11138, 74ACT11138 3-LINE TO 8-LINE DECODERS/DEMULTIPLEXERS

SCAS050A - D3266, JANUARY 1989 - REVISED APRIL 1993

electrical characteristics over recommended operating free-air temperature range (unless otherwise noted)

PARAMETER	TEST CONDITIONS	V _{CC}	T _A = 25°C			54ACT11138		74ACT11138		UNIT
			MIN	TYP	MAX	MIN	MAX	MIN	MAX	
V _{OH}	I _{OH} = -50 μA	4.5 V		4.4		4.4		4.4	V	
		5.5 V		5.4		5.4		5.4		
	I _{OH} = -24 mA	4.5 V		3.94		3.7		3.8		
		5.5 V		4.94		4.7		4.8		
	I _{OH} = -50 mA†	5.5 V				3.85				
I _{OH} = -75 mA†	5.5 V						3.85			
V _{OL}	I _{OL} = 50 μA	4.5 V				0.1		0.1	V	
		5.5 V				0.1		0.1		
	I _{OL} = 24 mA	4.5 V				0.36		0.44		
		5.5 V				0.36		0.44		
	I _{OL} = 50 mA†	5.5 V					1.65			
I _{OL} = 75 mA†	5.5 V						1.65			
I _I	V _I = V _{CC} or GND	5.5 V			± 0.1		± 1	± 1	μA	
I _{CC}	V _I = V _{CC} or GND, I _O = 0	5.5 V			4		80	40	μA	
ΔI _{CC} ‡	One input at 3.4 V, Other inputs at GND or V _{CC}	5.5 V			0.9		1	1	mA	
C _I	V _I = V _{CC} or GND	5 V			3.5				pF	

† Not more than one output should be tested at a time, and the duration of the test should not exceed 10 ms.

‡ This is the increase in supply current for each input that is at one of the specified TTL voltage levels rather than 0 V or V_{CC}.

switching characteristics over recommended ranges of supply voltage and free-air temperature (unless otherwise noted) (see Figure 1)

PARAMETER	FROM (INPUT)	TO (OUTPUT)	T _A = 25°C			54ACT11138		74ACT11138		UNIT
			MIN	TYP	MAX	MIN	MAX	MIN	MAX	
t _{PLH}	A, B, C	Any Y	1.5	6.1	8.9	1.5	10.5	1.5	9.8	ns
t _{PHL}			1.5	6	8.7	1.5	10.3	1.5	9.7	
t _{PLH}	G1	Y	1.5	5.5	8	1.5	9.4	1.5	8.9	ns
t _{PHL}			1.5	6	7.9	1.5	9.5	1.5	8.9	
t _{PLH}	G2A, G2B	Any Y	1.5	6.4	8.3	1.5	9.9	1.5	9.3	ns
t _{PHL}			1.5	6	8.8	1.5	10.5	1.5	9.8	

operating characteristics, V_{CC} = 5 V, T_A = 25°C

PARAMETER	TEST CONDITIONS	TYP	UNIT
C _{pd} Power dissipation capacitance	C _L = 50 pF, f = 1 MHz	88	pF

54ACT11138, 74ACT11138
3-LINE TO 8-LINE DECODERS/DEMULTIPLEXERS

SCAS050A – D3266, JANUARY 1989 – REVISED APRIL 1993

PARAMETER MEASUREMENT INFORMATION

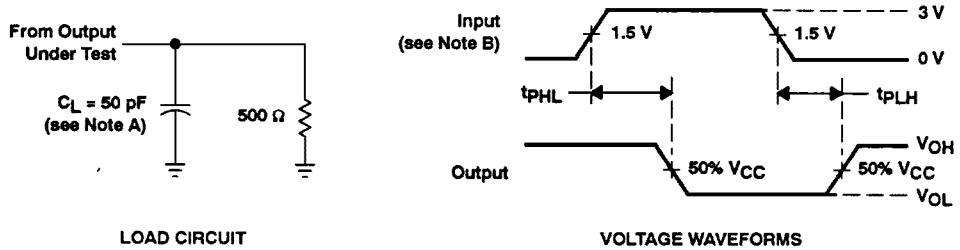

- NOTES: A. C_L includes probe and jig capacitance.
B. Input pulses are supplied by generators having the following characteristics: $PRR \leq 10 \text{ MHz}$, $Z_O = 50 \Omega$, $t_r = 3 \text{ ns}$, $t_f = 3 \text{ ns}$.
C. The outputs are measured one at a time with one input transition per measurement.

Figure 1. Load Circuit and Voltage Waveforms

