

MARKETING SALES DRAWING

DIMENSIONS IN INCHES - DO NOT SCALE THIS DRAWING

Electrical Testing
per Tusonix standard
test plans and Mil-Std-202
Test Methods.

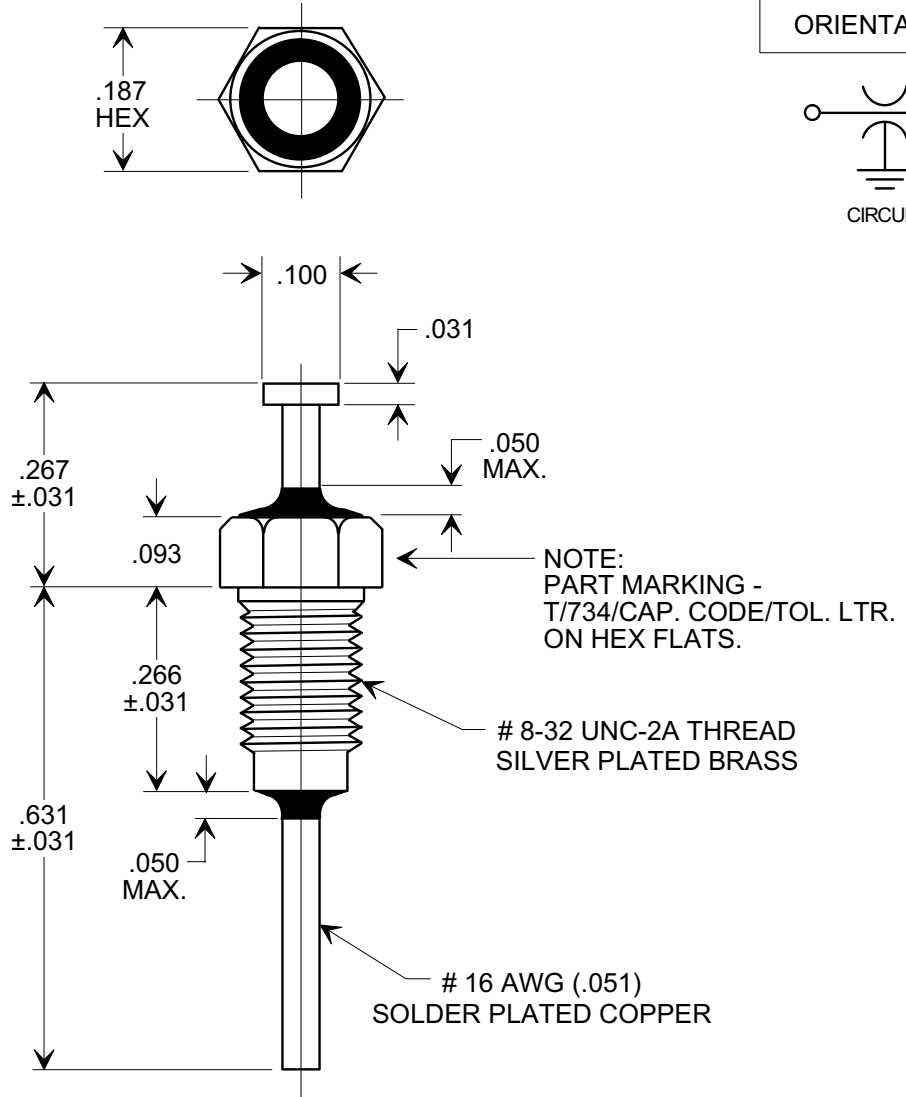
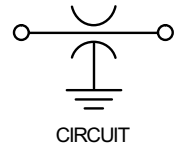
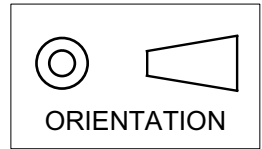

NOTE:
 1. SUPPLIED WITH SILVER PLATED HEX NUT AND INTERNAL TOOTH LOCK WASHER.

TUSONIX PART NUMBER	2425-734-X7U0-102Z
CAP. VALUE	1000 pF
CAP. TOL.	+80, -20 %
TEMP. COEF.	X7U
VOLT. RATING	100 VDC +125°C
OPERATING TEMP. RANGE	-55 TO +125°C
TESTED TO TUSONIX EQUIVALENT TO MIL-C39014 FOR GROUP A INSPECTION INCLUDING SUMMARY TEST DATA	

X-2015 Rev-0 REVISION RECORD Original Release C.O. 20000301-4-01	0	--TOLERANCES-- Unless Otherwise Specified DECIMAL ± .015 ANGLES ±	Title HI-RELIABILITY COMMERCIAL REPLACEMENT FOR M39014/18 (CKR76) FEED-THRU CAPACITOR		
	TUSONIX TUCSON, ARIZONA		Drawn S.M. 03-01-00	Scale 4 X	
	A		Approved T.C. 03-01-00		
	2425-734-X7UO-102Z				