

# XC62FP

## Series

Positive Voltage Regulators



- ◆ CMOS Low Power Consumption
- ◆ Small Input-Output Voltage Differential
  - : 0.12V @ 100mA,
  - 0.38V @ 200mA
- ◆ Maximum Output Current : 250mA (V<sub>OUT</sub>=5.0V)
- ◆ Output Voltage Range : 2.0V~6.0V
- ◆ Highly Accurate : ±2% (±1%)

### General Description

The XC62FP series is a group of positive voltage output, three-pin regulators, that provide a high current even when the input/output voltage differential is small. Low power consumption and high accuracy is achieved through CMOS and laser trimming technologies.

The XC62FP consists of a high-precision voltage reference, an error amplification circuit, and a current limited output driver. Transient response to load variations have improved in comparison to the existing series.

SOT-23 (150mW), SOT-89 (500mW) and TO-92 (300mW) packages are available.

### Applications

- Battery Powered Equipment
- Palmtops
- Portable Cameras and Video Recorders
- Reference Voltage Sources

### Features

- Maximum Output Current**
  - : 250mA
  - (within max. power dissipation, V<sub>OUT</sub> = 5.0V)
- Output Voltage Range**
  - : 2.0V ~ 6.0V in 0.1V increments
  - (1.5V ~ 1.9V for custom products)
- Highly Accurate:** Output voltage ±2%
  - (±1% for semi-custom products)
- Low Power Consumption**
  - : Typ. 2.0μA @ V<sub>OUT</sub>=5.0V
- Output Voltage Temperature Characteristics**
  - : Typ. ±100ppm/°C
- Input Stability** : Typ. 0.2%/V
- Small Input-Output Differential**
  - : I<sub>OUT</sub> = 100mA @ V<sub>OUT</sub> = 5.0V with a
  - 0.12V differential.
- Ultra Small Packages**
  - : SOT-23 (150mW) mini-mold,
  - SOT-89 (500mW) mini-power mold
  - TO-92 (300mW)

### Typical Application Circuit

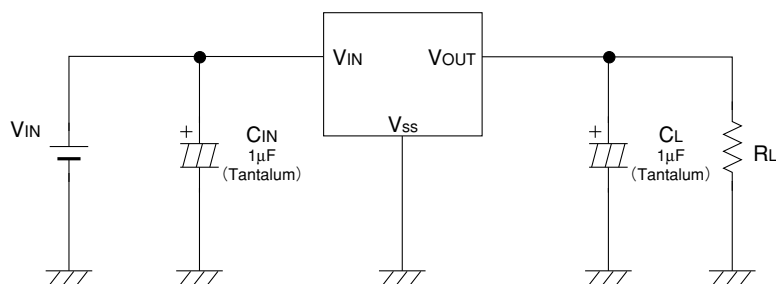

### Typical Performance Characteristic

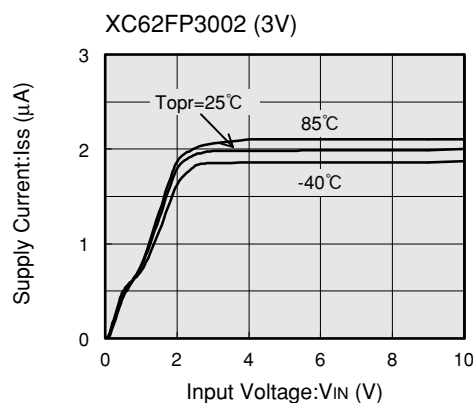

## Pin Configuration

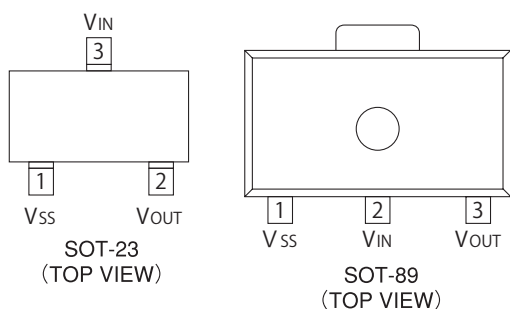

3

## Pin Assignment

PIN NUMBER		PIN NAME	FUNCTION
SOT-23	SOT-89		
1	1	V <sub>SS</sub>	Ground
3	2	V <sub>IN</sub>	Supply Voltage Input
2	3	V <sub>OUT</sub>	Regulated voltage output

## Product Classification

### Ordering Information

XC62FP①②③④⑤⑥-⑦

DESIGNATOR	DESCRIPTION	SYMBOL	DESCRIPTION
①②	Output Voltage	20~60	e.g. 30: 3.0V, 50: 5.0V
③	Temperature Coefficient	0	±100ppm
④	Output Voltage Accuracy	1	±1.0%(Semi-custom)
		2	±2.0%
⑤⑥-⑦ <sup>(*)</sup>	Package (Order Unit)	PR-G	SOT-89 (1,000/Reel)
		MR-G	SOT-23 (3,000/Reel)

<sup>(\*)</sup> The "-G" suffix denotes Halogen and Antimony free as well as being fully EU RoHS compliant.

## ■ Packaging Information

### ● SOT-23

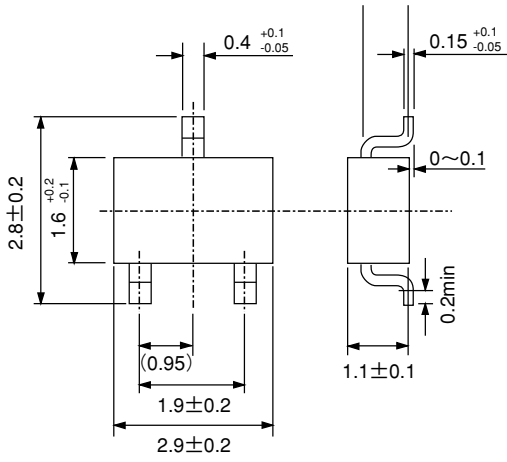

### ● SOT-89

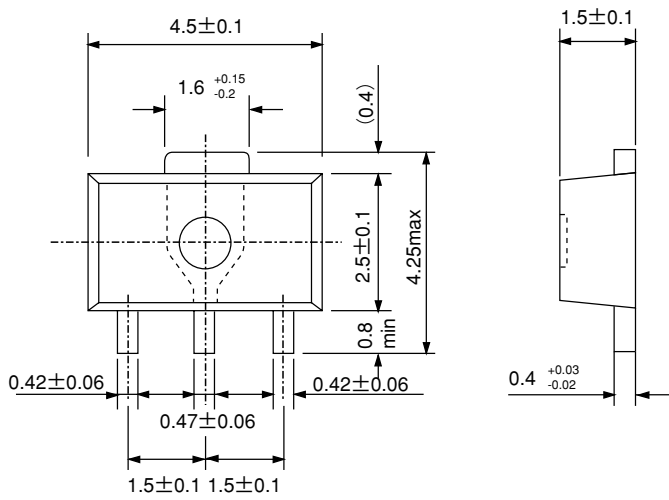

●TO-92

3

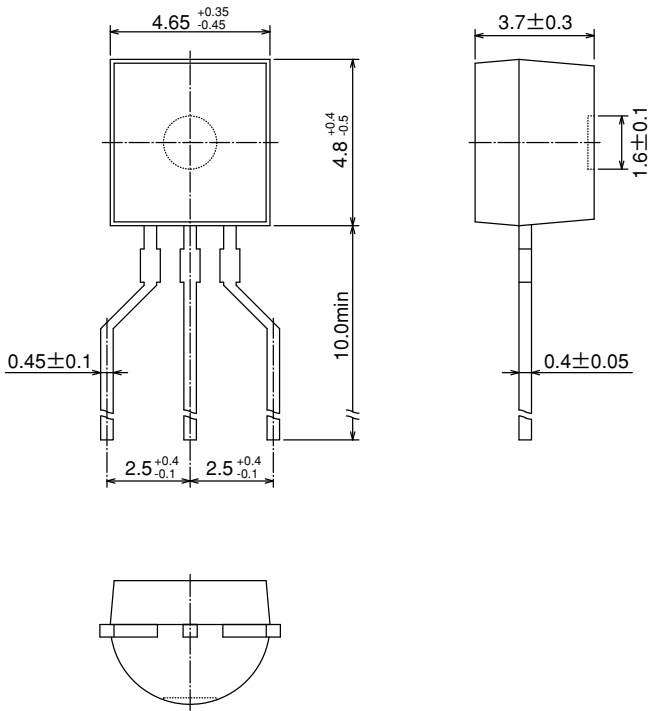

## Marking

●SOT-23, SOT-89

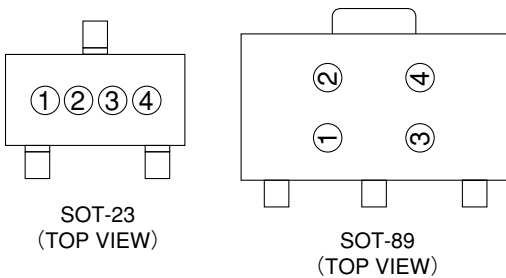

① Represents the integer of the Output Voltage

SYMBOL	VOLTAGE(V)	SYMBOL	VOLTAGE(V)
1	1.②	5	5.②
2	2.②	6	6.②
3	3.②		
4	4.②		

② Represents the decimal number of the Output Voltage

SYMBOL	VOLTAGE(V)	SYMBOL	VOLTAGE(V)
A	①.0	F	①.5
B	①.1	H	①.6
C	①.2	K	①.7
D	①.3	L	①.8
E	①.4	M	①.9

③ Based on internal standards

SYMBOL
0

④ Represents the assembly lot no.  
Based on internal standards

●TO-92

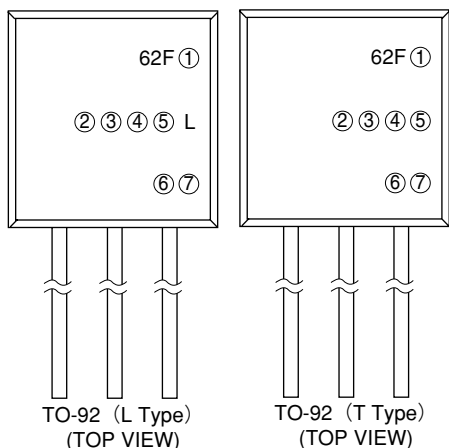

① Represents the polarity of Output Voltage

DESIGNATOR	CONFIGURATION
P	CMOS

④ Represents the temperature characteristics

DESIGNATOR	TEMPERATURE CHARACTERISTICS
0	TPY±100ppm

⑥ Represents a least significant digit of the produced year

DESIGNATOR	PRODUCED YEAR
0	2000
1	2001

⑦ Denotes the production lot number  
0 to 9, A to Z repeated (G.I.J.O.Q.W excepted)

②③ Represents the Detect Voltage

DESIGNATOR		VOLTAGE (V)
②	③	
3	3	3.3
5	0	5.0

⑤ Represents the Detect Voltage Accuracy

DESIGNATOR	DETECT VOLTAGE ACCURACY
1	within ±1% (semi-custom)
2	within ±2%

■Block Diagram

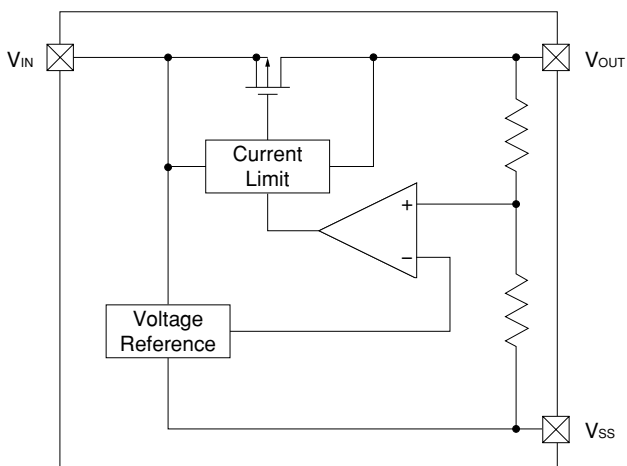

■Absolute Maximum Ratings

Ta=25°C

PARAMETER	SYMBOL	RATINGS	UNITS
Input Voltage	V <sub>IN</sub>	12	V
Output Current	I <sub>OUT</sub>	500	mA
Output Voltage	V <sub>OUT</sub>	V <sub>SS</sub> -0.3 ~ V <sub>IN</sub> +0.3	V
Continuous Total Power Dissipation	SOT-23	150	mW
	SOT-89	500	
	TO-92	300	
Operating Ambient Temperature	T <sub>opr</sub>	-40 ~ +85	°C
Storage Temperature	T <sub>stg</sub>	-40 ~ +125	°C

## Electrical Characteristics

XC62FP5002  $V_{OUT}(T)=5.0V$  (Note1)

$T_a=25^\circ C$

PARAMETER	SYMBOL	CONDITIONS	MIN	TYP	MAX	UNITS	CIRCUIT
Output Voltage	$V_{OUT}$ (E) (Note2)	$I_{OUT}=40mA$ $V_{IN}=6.0V$	4.900	5.000	5.100	V	1
Maximum Output Current	$I_{OUT\ max}$	$V_{IN}=6.0V, V_{OUT}(E) \geq 4.5V$	250			mA	1
Load Stability	$\Delta V_{OUT}$	$V_{IN}=6.0V$ $1mA \leq I_{OUT} \leq 100mA$		40	80	mV	1
Input -Output Voltage Differential (Note3)	Vdif1	$I_{OUT}=100mA$		120	300	mV	1
	Vdif2	$I_{OUT}=200mA$		380	600	mV	1
Supply Current	$I_{SS}$	$V_{IN}=6.0V$		2.0	4.5	$\mu A$	2
Input Stability	$\frac{\Delta V_{OUT}}{\Delta V_{IN} \cdot V_{OUT}}$	$I_{OUT}=40mA$ $6.0V \leq V_{IN} \leq 10.0V$		0.2	0.3	%/V	1
Input Voltage	$V_{IN}$				10	V	—
Output Voltage Temperature Characteristics	$\frac{\Delta V_{OUT}}{\Delta T_{opr} \cdot V_{OUT}}$	$I_{OUT}=40mA$ $-40^\circ C \leq T_{opr} \leq 85^\circ C$		$\pm 100$		ppm/ $^\circ C$	1

XC62FP4002  $V_{OUT}(T)=4.0V$  (Note1)

$T_a=25^\circ C$

PARAMETER	SYMBOL	CONDITIONS	MIN	TYP	MAX	UNITS	CIRCUIT
Output Voltage	$V_{OUT}$ (E) (Note2)	$I_{OUT}=40mA$ $V_{IN}=5.0V$	3.920	4.000	4.080	V	1
Maximum Output Current	$I_{OUT\ max}$	$V_{IN}=5.0V, V_{OUT}(E) \geq 3.6V$	200			mA	1
Load Stability	$\Delta V_{OUT}$	$V_{IN}=5.0V$ $1mA \leq I_{OUT} \leq 100mA$		45	90	mV	1
Input -Output Voltage Differential (Note3)	Vdif1	$I_{OUT}=100mA$		170	330	mV	1
	Vdif2	$I_{OUT}=200mA$		400	630	mV	1
Supply Current	$I_{SS}$	$V_{IN}=5.0V$		2.0	4.5	$\mu A$	2
Input Stability	$\frac{\Delta V_{OUT}}{\Delta V_{IN} \cdot V_{OUT}}$	$I_{OUT}=40mA$ $5.0V \leq V_{IN} \leq 10.0V$		0.2	0.3	%/V	1
Input Voltage	$V_{IN}$				10	V	—
Output Voltage Temperature Characteristics	$\frac{\Delta V_{OUT}}{\Delta T_{opr} \cdot V_{OUT}}$	$I_{OUT}=40mA$ $-40^\circ C \leq T_{opr} \leq 85^\circ C$		$\pm 100$		ppm/ $^\circ C$	1

**XC62FP3002**  $V_{OUT}(T)=3.0V$  (Note1)

$T_a=25^{\circ}C$

PARAMETER	SYMBOL	CONDITIONS	MIN	TYP	MAX	UNITS	CIRCUIT
Output Voltage	$V_{OUT}(E)$ (Note2)	$I_{OUT}=40mA$ $V_{IN}=4.0V$	2.940	3.000	3.060	V	1
Maximum Output Current	$I_{OUT\ max}$	$V_{IN}=4.0V, V_{OUT}(E) \geq 2.7V$	150			mA	1
Load Stability	$\Delta V_{OUT}$	$V_{IN}=4.0V$ $1mA \leq I_{OUT} \leq 80mA$		45	90	mV	1
Input -Output Voltage Differential (Note3)	Vdif1	$I_{OUT}=80mA$		180	360	mV	1
	Vdif2	$I_{OUT}=160mA$		400	700	mV	1
Supply Current	$I_{SS}$	$V_{IN}=4.0V$		2.0	4.5	$\mu A$	2
Input Stability	$\frac{\Delta V_{OUT}}{\Delta V_{IN} \cdot V_{OUT}}$	$I_{OUT}=40mA$ $4.0V \leq V_{IN} \leq 10.0V$		0.2	0.3	%/V	1
Input Voltage	$V_{IN}$				10	V	—
Output Voltage Temperature Characteristics	$\frac{\Delta V_{OUT}}{\Delta T_{opr} \cdot V_{OUT}}$	$I_{OUT}=40mA$ $-40^{\circ}C \leq T_{opr} \leq 85^{\circ}C$		$\pm 100$		ppm/ $^{\circ}C$	1

**XC62FP2002**  $V_{OUT}(T)=2.0V$  (Note1)

$T_a=25^{\circ}C$

PARAMETER	SYMBOL	CONDITIONS	MIN	TYP	MAX	UNITS	CIRCUIT
Output Voltage	$V_{OUT}(E)$ (Note2)	$I_{OUT}=40mA$ $V_{IN}=3.0V$	1.960	2.000	2.040	V	1
Maximum Output Current	$I_{OUT\ max}$	$V_{IN}=3.0V, V_{OUT}(E) \geq 1.8V$	100			mA	1
Load Stability	$\Delta V_{OUT}$	$V_{IN}=3.0V$ $1mA \leq I_{OUT} \leq 60mA$		45	90	mV	1
Input -Output Voltage Differential (Note3)	Vdif1	$I_{OUT}=60mA$		180	360	mV	1
	Vdif2	$I_{OUT}=120mA$		400	700	mV	1
Supply Current	$I_{SS}$	$V_{IN}=3.0V$		2.0	4.5	$\mu A$	2
Input Stability	$\frac{\Delta V_{OUT}}{\Delta V_{IN} \cdot V_{OUT}}$	$I_{OUT}=40mA$ $3.0V \leq V_{IN} \leq 10.0V$		0.2	0.3	%/V	1
Input Voltage	$V_{IN}$				10	V	—
Output Voltage Temperature Characteristics	$\frac{\Delta V_{OUT}}{\Delta T_{opr} \cdot V_{OUT}}$	$I_{OUT}=40mA$ $-40^{\circ}C \leq T_{opr} \leq 85^{\circ}C$		$\pm 100$		ppm/ $^{\circ}C$	1

- Note:
- $V_{OUT}(T)$ =Specified Output Voltage .
  - $V_{OUT}(E)$ =Effective Output Voltage (i.e. the output voltage when " $V_{OUT}(T)+1.0V$ " is provided at the  $V_{IN}$  pin while maintaining a certain  $I_{OUT}$  value).
  - $V_{dif} = \{V_{IN1} (Note4) - V_{OUT}(E)\}$
  - $V_{IN1}$ = The input voltage at the time 98% of  $V_{OUT}(E)$  is output (input voltage has been gradually reduced).

## Typical Application Circuit

### Standard Circuit

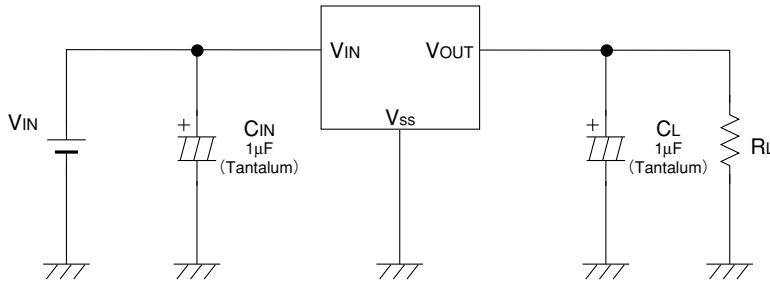

3

## Directions for use

### Notes on Use

1. Please use this IC within the stipulated absolute maximum ratings as the IC is liable to malfunction outside of such parameters.
2. There is a possibility that oscillation may occur as a result of the impedance present between the power supply and the IC's input. Where impedance is  $10\Omega$  or more, please use a capacitor ( $C_{IN}$ ) of at least  $1\mu F$ .

With a large output current, operations can be stabilised by increasing capacitor size ( $C_{IN}$ ). If  $C_{IN}$  is small and capacitor size ( $C_L$ ) is increased, there is a possibility of oscillation due to input impedance.

In such cases, operations can be stabilised by either increasing the size of  $C_{IN}$  or decreasing the size of  $C_L$ .

3. Please ensure that output current ( $I_{OUT}$ ) is less than  $P_d \div (V_{IN} - V_{OUT})$  and does not exceed the stipulated Continuous Total Power Dissipation value ( $P_d$ ) for the package.
4. Should you wish to increase output current ( $I_{OUT}$ ) and/or have the capability to exceed the stipulated  $P_d$  value, using a current boost circuit (similar to the one shown below) is likely to lead to oscillation.

With such applications, we recommend use of a boost type voltage regulator, such as the Torex XC62EP series.

### Current Boost Circuit : Poor Example

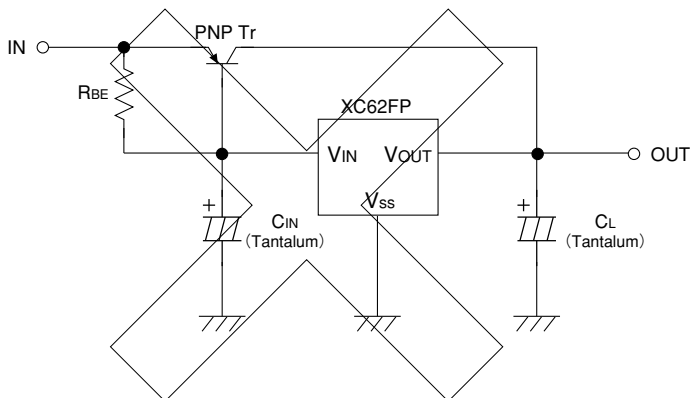



## ■ Test Circuits

Circuit 1

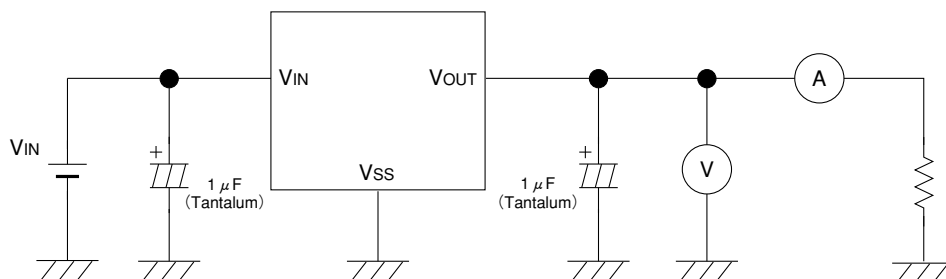

**3**

Circuit 2

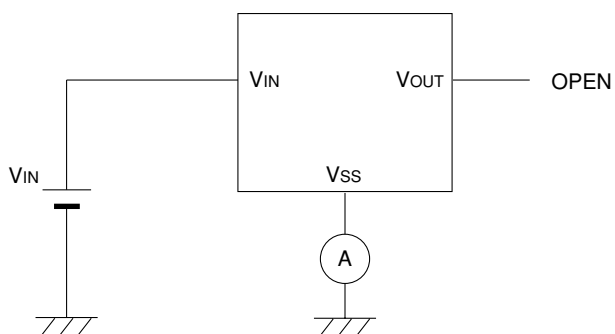

## Typical Performance Characteristics

### (1) OUTPUT VOLTAGE vs. OUTPUT CURRENT

3

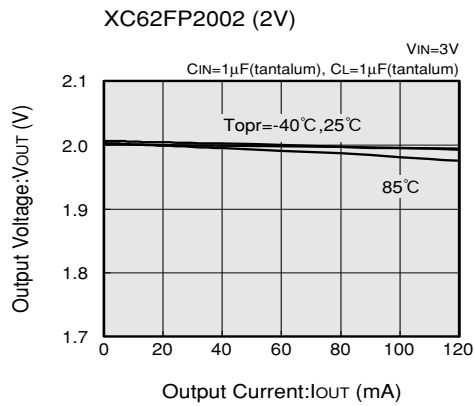
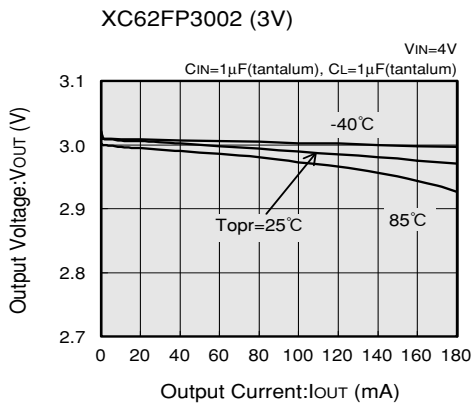
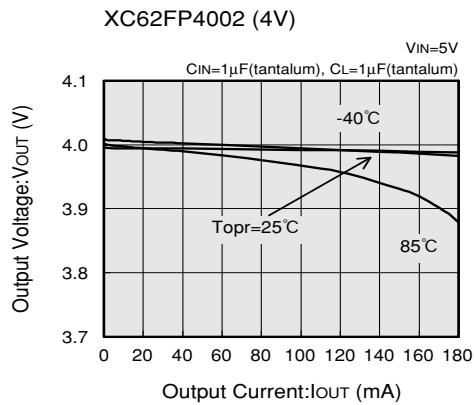
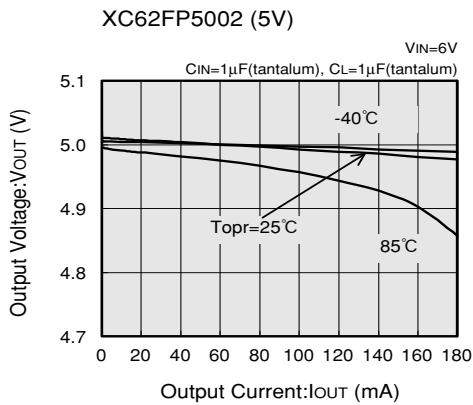

### (2) OUTPUT VOLTAGE vs. INPUT VOLTAGE

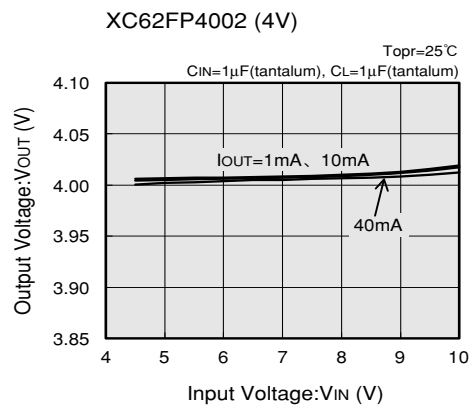
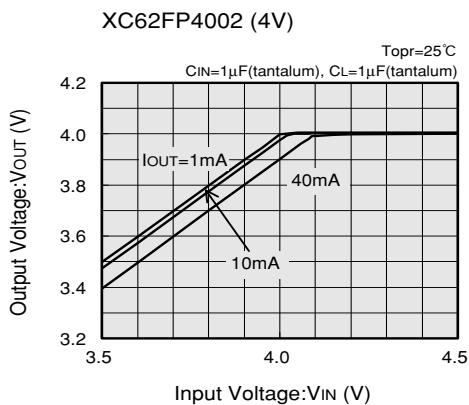
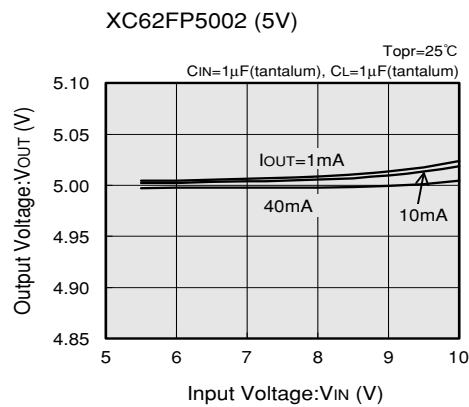
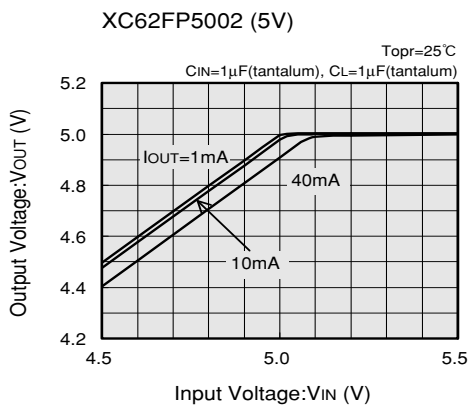

**(2) OUTPUT VOLTAGE vs. INPUT VOLTAGE**

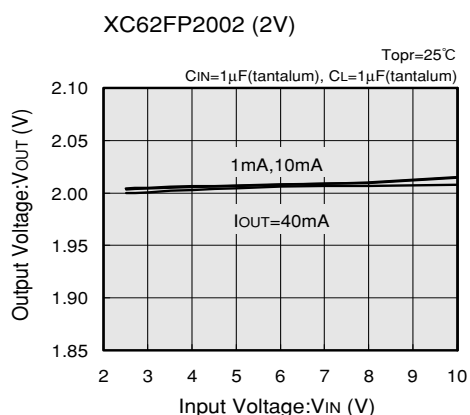
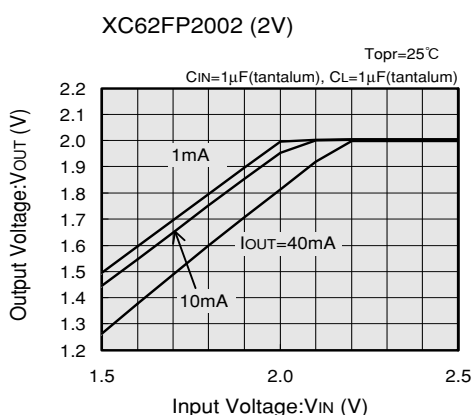
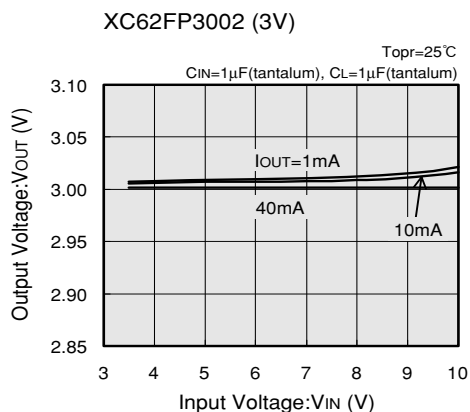
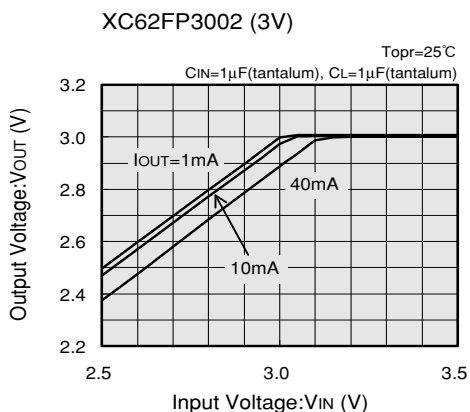

**(3) INPUT/OUTPUT VOLTAGE DIFFERENTIAL vs. OUTPUT CURRENT**

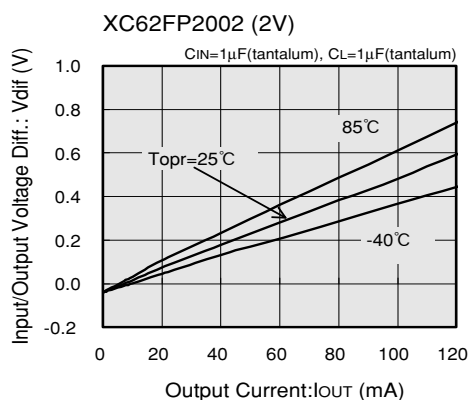
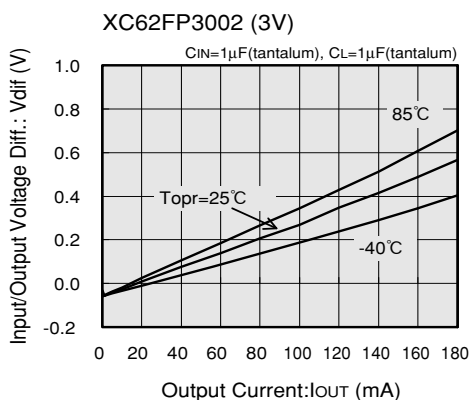
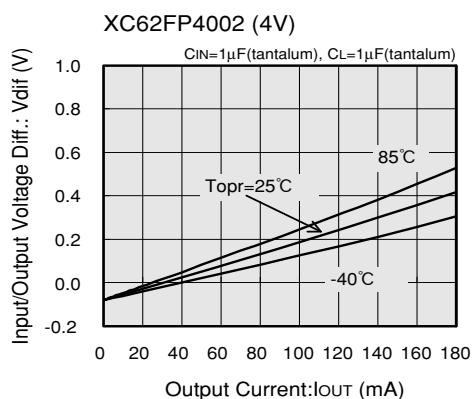
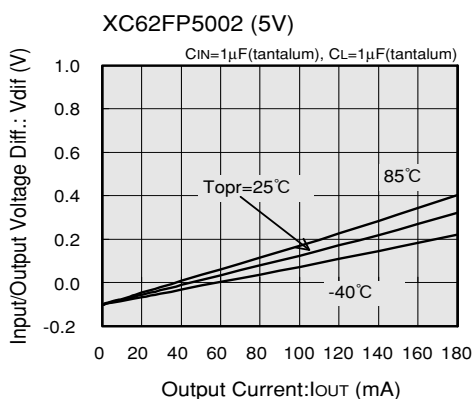

## (4) SUPPLY CURRENT vs. INPUT VOLTAGE

3

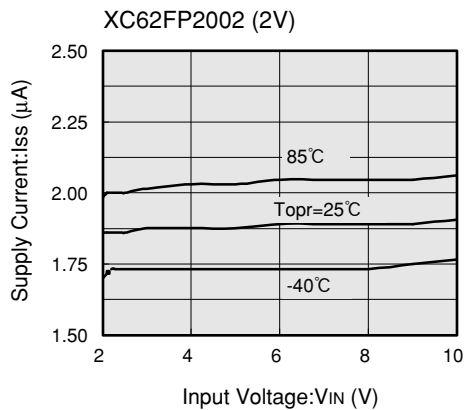
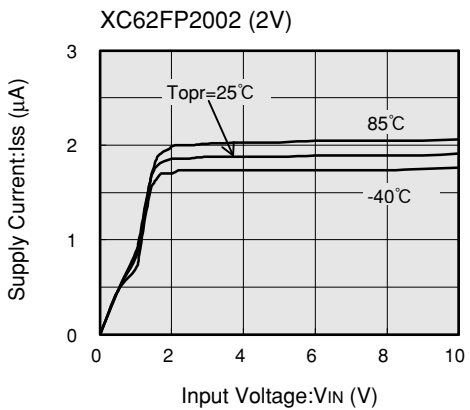
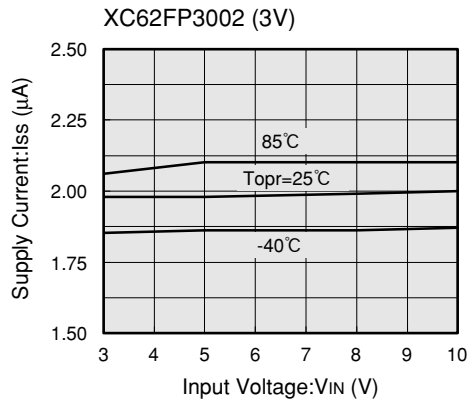
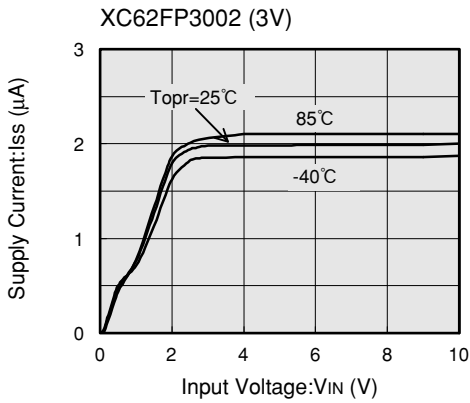
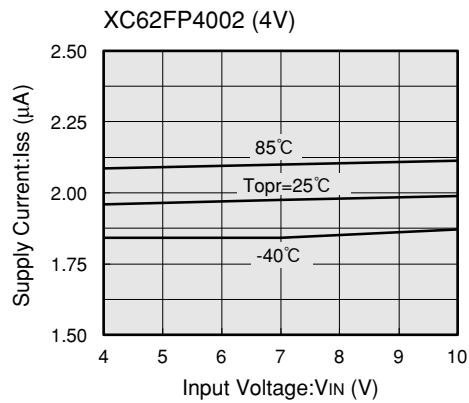
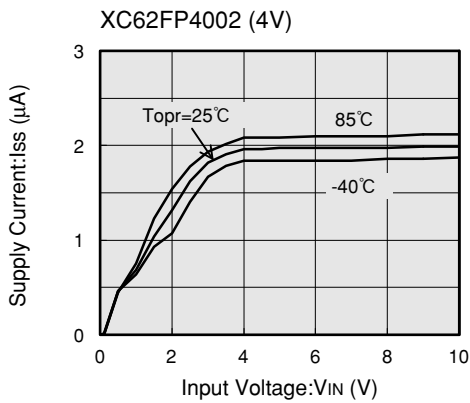
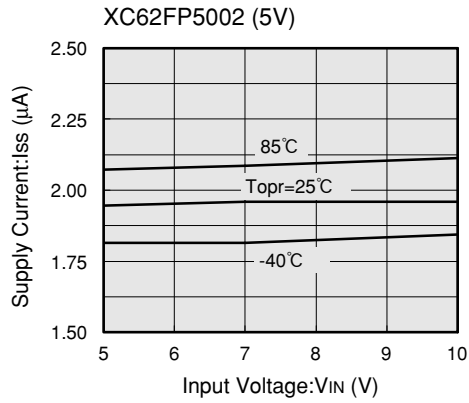
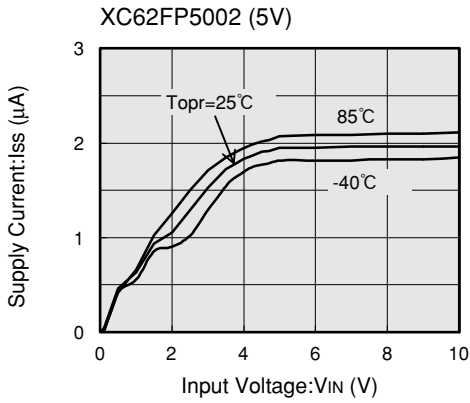

**(5) OUTPUT VOLTAGE vs. AMBIENT TEMPERATURE**

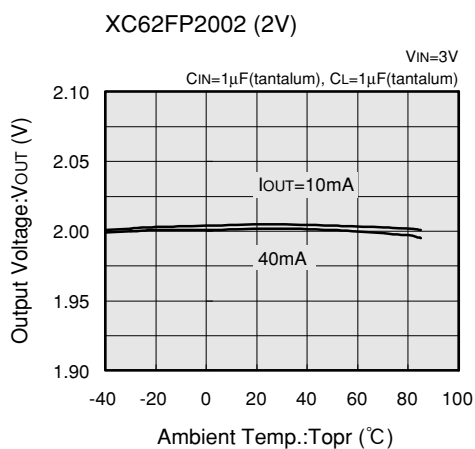
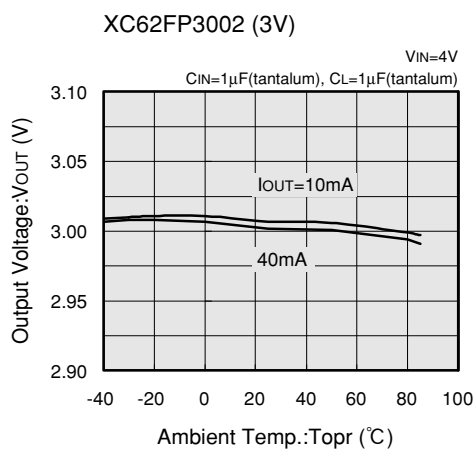
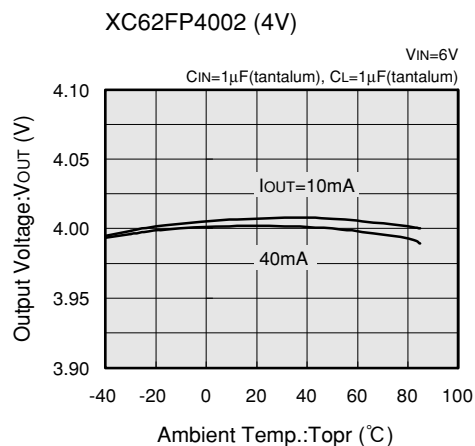
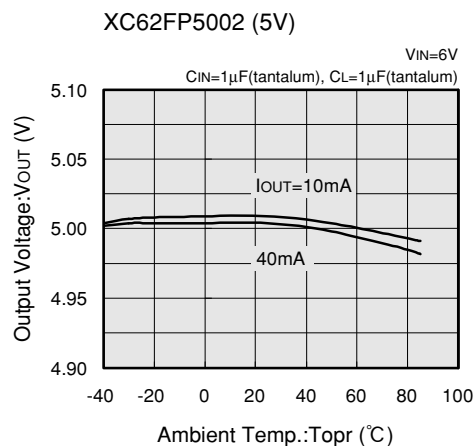

**(6) SUPPLY CURRENT vs. AMBIENT TEMPERATURE**

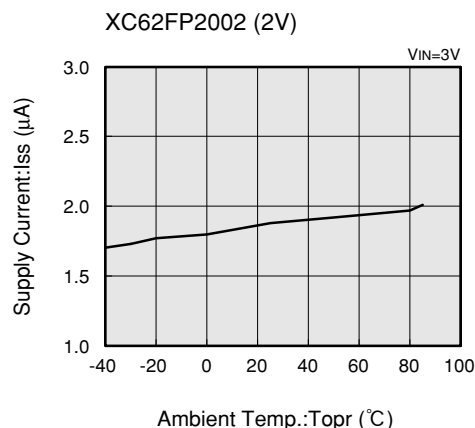
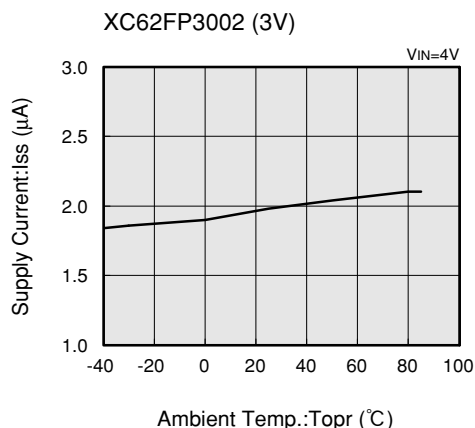
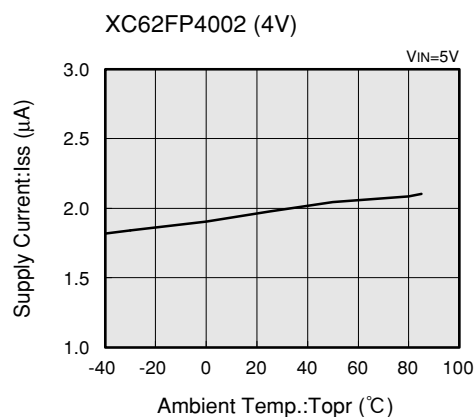
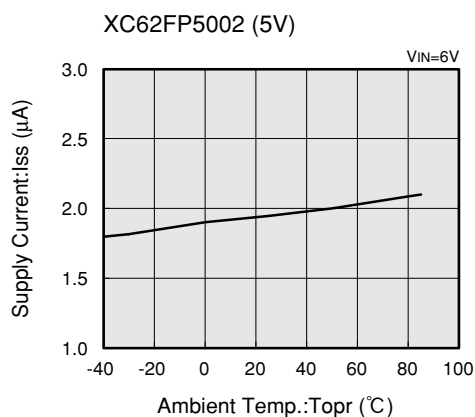

3

## (7) INPUT TRANSIENT RESPONSE 1

3

XC62FP5002 (5V)

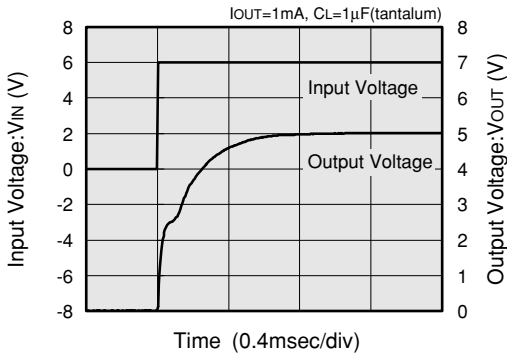

XC62FP5002 (5V)

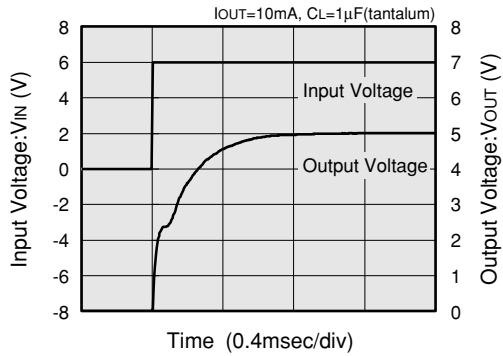

XC62FP4002 (4V)

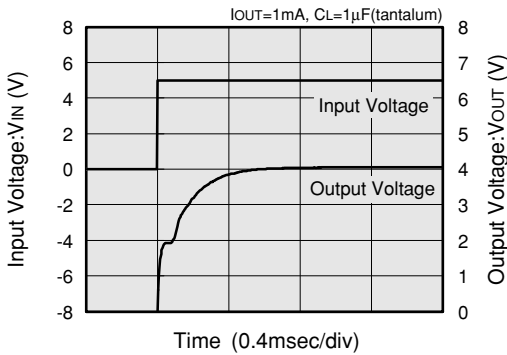

XC62FP4002 (4V)

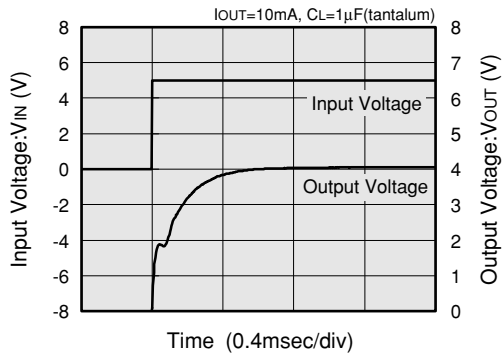

XC62FP3002 (3V)

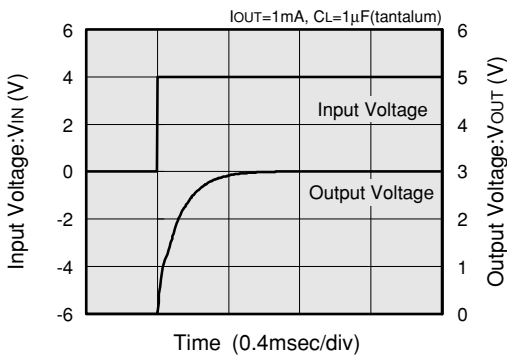

XC62FP3002 (3V)

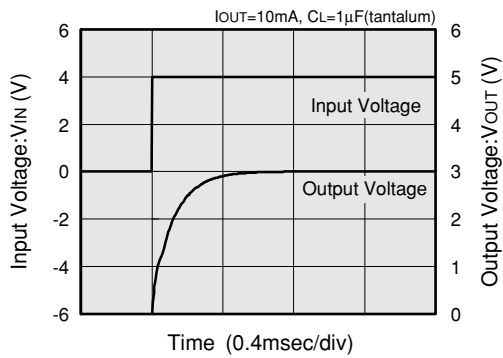

XC62FP2002 (2V)

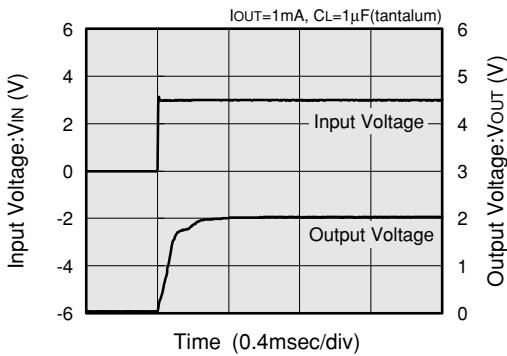

XC62FP2002 (2V)

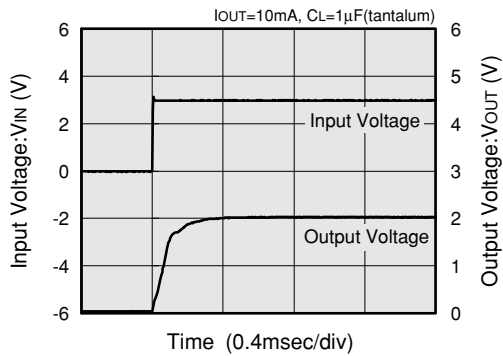

(8) INPUT TRANSIENT RESPONSE 2

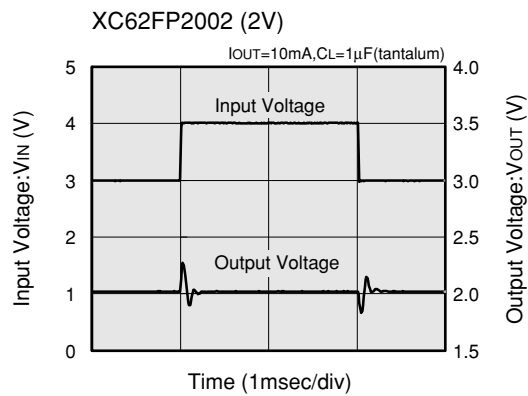
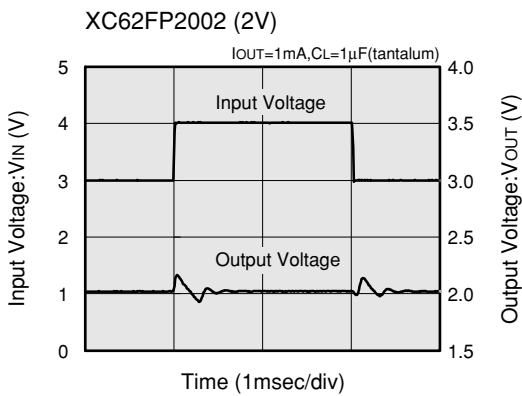
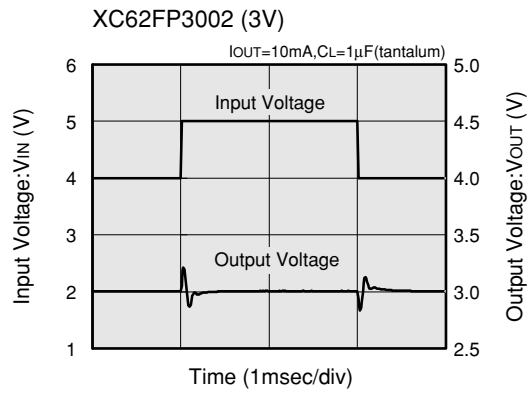
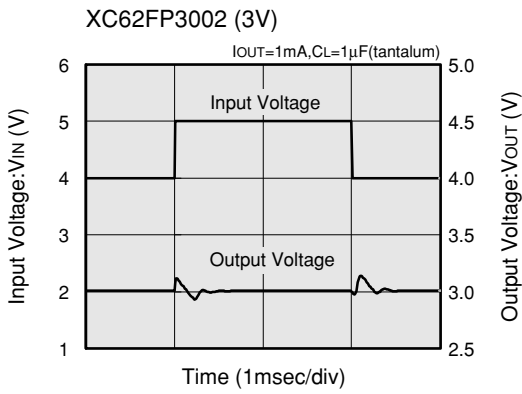
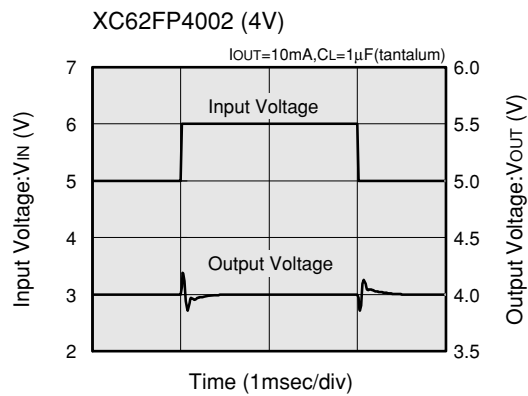
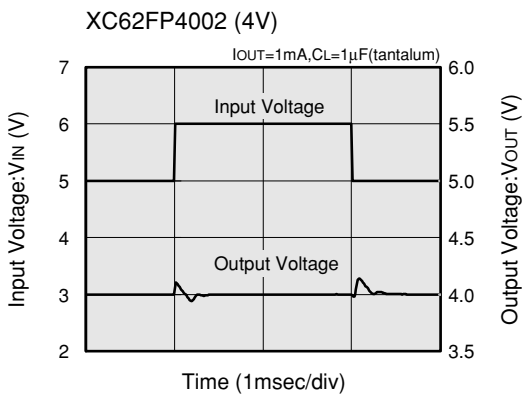
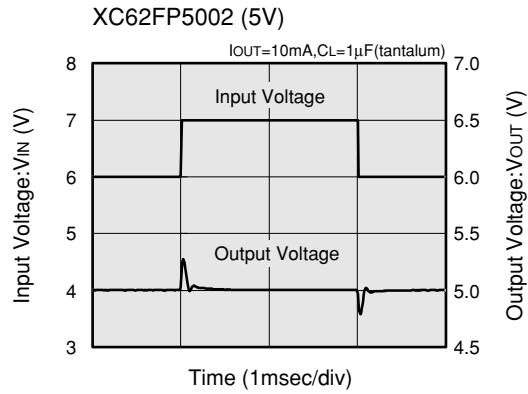
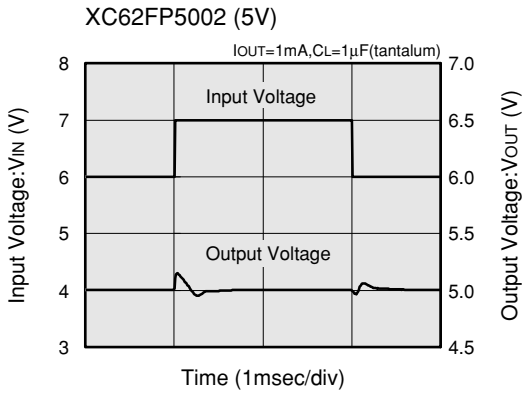

## (9) LOAD TRANSIENT RESPONSE

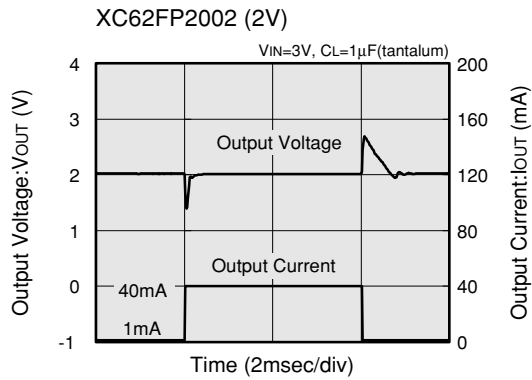
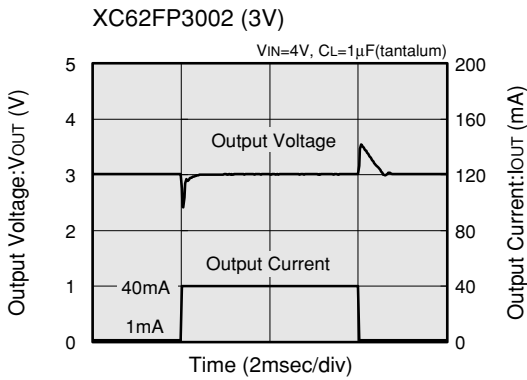
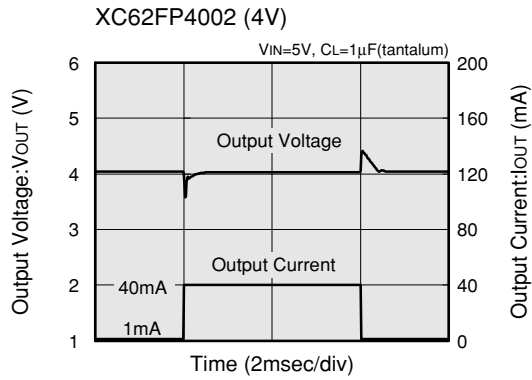
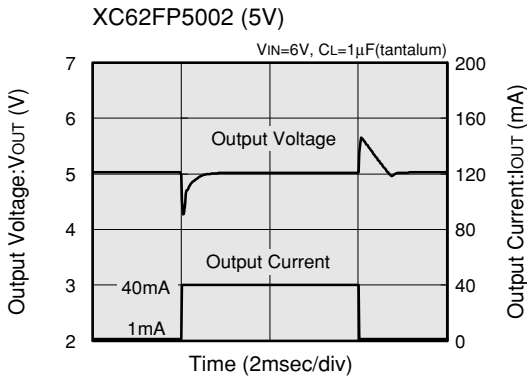

## (10) RIPPLE REJECTION RATE

