



PART NUMBER	DESCRIPTION
CCT-39S	Commercial Latching Multi-throw, DC-12GHz
<p>The CCT-39S is a broadband, multi-throw, electromechanical coaxial switch designed to switch a microwave signal from a common input to any of 7 or 8 outputs. The characteristic impedance is 50 Ohms. Each position has an individual actuator mechanism allowing random position selection. This also minimizes switching time.</p> <p>The CCT-39S comes with a latching actuator. The latching switch remains in the last position selected when the switch is de-energized. STD dual command requires a reset pulse before a new selected position. A separate reset circuit allows all positions to be set to an open position. User must provide both reset (clear) and set (select new position) commands.</p>	



ENVIRONMENTAL AND PHYSICAL CHARACTERISTICS	
Operating Temperature Commercial Model, CCT-39S	-40°C to 65°C
Vibration (MIL-STD-202 Method 214, Condition D, non-operating)	10 g's RMS
Shock (MIL-STD-202 Method 213, Condition D, non-operating)	500 g's
Standard Actuator Life	3,000,000 cycles
Actuator Life w/ Additional Features	1,000,000 cycles
Connector Type	SMA
Humidity (Moisture Seal)	Available
Weight	9 oz. (255.2g) (max.)

ELECTRICAL CHARACTERISTICS	
Form Factor	Multi-Throw, break before make
Frequency Range CCT-39S	DC-12 GHz
Characteristic Impedance	50 Ohms
Operate Time	20 ms (max.)
Actuation Voltage Available	12 15 24 28 V
Actuation Current	110 105 90 105 mA
Reset Currents (# of positions)	
	(7) 770 735 630 735 mA
	(8) 880 840 720 840 mA

PERFORMANCE CHARACTERISTICS		
Frequency	DC-6 GHz	6-12 GHz
Insertion Loss, dB, max.	0.2	0.4
Isolation, dB, min.	70	60
VSWR , max.	1.30:1	1.40:1

PART NUMBERING SYSTEM

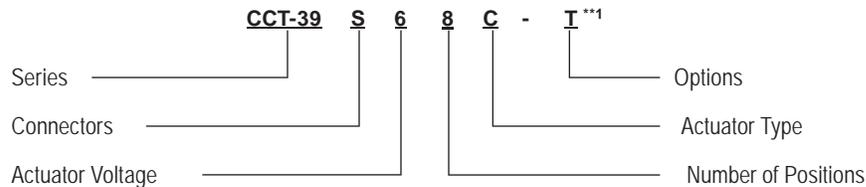

CONNECTOR	ACTUATOR VOLTAGE	NUMBER OF POSITIONS	ACTUATOR TYPE	OPTIONS
S: SMA FEMALE	6: 28 VDC LATCHING	7: SP7T	0: NO INDICATOR CONTACTS	T: TTL DRIVERS WITH DIODES
	7: 15 VDC LATCHING	8: SP8T	C: INDICATOR CONTACTS	D: COIL TRANSIENT SUPPRESSION DIODES
	8: 12 VDC LATCHING			R: POSITIVE + COMMON
	9: 24 VDC LATCHING			TD: DECODERS AND TTL DRIVERS WITH DIODES
				M: MOISTURE SEAL
				S: D-SUB CONNECTOR*

**SEE PART NUMBER ON PAGE 10

For additional options, please contact factory.

* D-Sub Connector may be 15 or 26 pin depending on number of throws. (See Connector Pinout page)

*** D-Sub Connectors is standard configuration on all models unless otherwise specified

Series CCT-39S
Multi-Throw DC-12 GHz, SP7T & SP8T
Latching Coaxial Switch, Internal 50Ω Termination



SCHEMATICS AND MECHANICAL OUTLINE

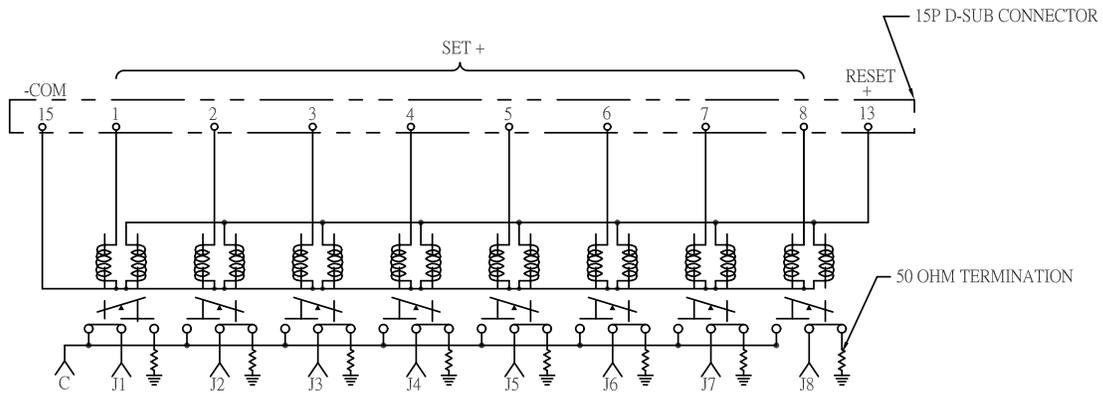

SCHEMATIC
 COIL 1 SHOWN LAST ENERGIZE

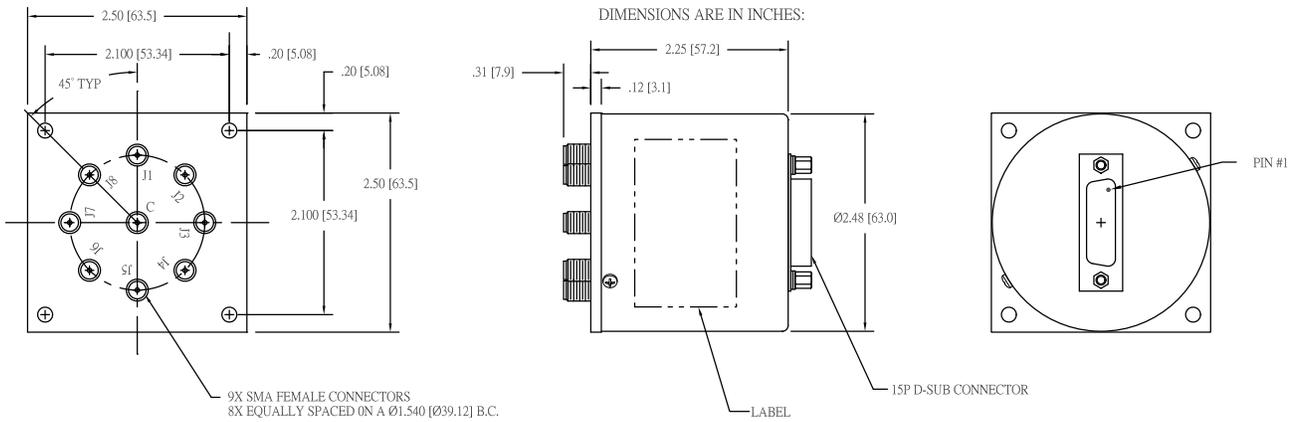

“-S OPTION” 15-PIN D-SUB OR 26-PIN D-MICRO CONNECTOR (EXAMPLE: CCT-39S680-S)

CONNECTOR PINOUT FOR LATCHING SP7T MULTI-THROW SWITCHES						
EXAMPLE	CCT-39S670-S	CCT-39S67C-S	CCT-39S670-TS	CCT-39S67C-TS	CCT-39S670-TDS	CCT-39S67C-TDS
INDICATOR		Yes		Yes		Yes
TTL			Yes	Yes		
Decoders & TTL					Yes	Yes
PIN NO.	15-PIN	26-PIN	15-PIN	26-PIN	15-PIN	26-PIN
1	PORT 1	PORT 1	TTL 1	TTL 1	LOGIC 1	LOGIC 1
2	PORT 2	PORT 2	TTL 2	TTL 2	LOGIC 2	LOGIC 2
3	PORT 3	PORT 3	TTL 3	TTL 3	LOGIC 3	LOGIC 3
4	PORT 4	PORT 4	TTL 4	TTL 4		
5	PORT 5	PORT 5	TTL 5	TTL 5		
6	PORT 6	PORT 6	TTL 6	TTL 6		
7	PORT 7	PORT 7	TTL 7	TTL 7		
8						
9						
10						
11						
12						
13			Vsw	Vsw	Vsw	Vsw
14	Reset	Reset	Reset	Reset		
15	COMMON	COMMON	COMMON	COMMON	COMMON	COMMON
16		D Indicator (COM)		D Indicator (COM)		D Indicator (COM)
17		E Indicator		E Indicator		E Indicator
18		F Indicator		F Indicator		F Indicator
19		G Indicator		G Indicator		G Indicator
20		H Indicator		H Indicator		H Indicator
21		K Indicator		K Indicator		K Indicator
22		L Indicator		L Indicator		L Indicator
23		M Indicator		M Indicator		M Indicator
24						
25						
26						

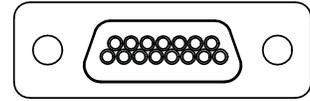

15-PIN D-SUB CONNECTOR

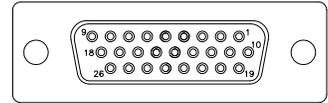

26-PIN D-SUB CONNECTOR

Series CCT-39S
Multi-Throw DC-12 GHz, SP7T & SP8T
Latching Coaxial Switch, Internal 50Ω Termination



SP7T TRUTH TABLE Latching
CCT-39SX7C-T

Logic Input								RF Path								Indicator Switches						
1	2	3	4	5	6	7	R	J1	J2	J3	J4	J5	J6	J7	Reset	E	F	G	H	K	L	M
1	0	0	0	0	0	0	0	On	Off	Off	Off	Off	Off	Off	Off	C	0	0	0	0	0	0
0	1	0	0	0	0	0	0	Off	On	Off	Off	Off	Off	Off	Off	0	C	0	0	0	0	0
0	0	1	0	0	0	0	0	Off	Off	On	Off	Off	Off	Off	Off	0	0	C	0	0	0	0
0	0	0	1	0	0	0	0	Off	Off	Off	On	Off	Off	Off	Off	0	0	0	C	0	0	0
0	0	0	0	1	0	0	0	Off	Off	Off	Off	On	Off	Off	Off	0	0	0	0	C	0	0
0	0	0	0	0	1	0	0	Off	Off	Off	Off	Off	On	Off	Off	0	0	0	0	0	C	0
0	0	0	0	0	0	1	0	Off	Off	Off	Off	Off	Off	On	Off	0	0	0	0	0	0	C
0	0	0	0	0	0	0	1	Off	Off	Off	Off	Off	Off	On	Off	0	0	0	0	0	0	C

TRUTH TABLE Latching
CCT-39SX7C-TD

Logic Input				RF Path						Indicator Switches								
1	2	3	4	J1	J2	J3	J4	J5	J6	J7	Reset	E	F	G	H	K	L	M
0	0	0	0	On	Off	Off	Off	Off	Off	Off	Off	C	0	0	0	0	0	0
1	0	0	0	Off	On	Off	Off	Off	Off	Off	Off	0	C	0	0	0	0	0
0	1	0	0	Off	Off	On	Off	Off	Off	Off	Off	0	0	C	0	0	0	0
1	1	0	0	Off	Off	Off	On	Off	Off	Off	Off	0	0	0	C	0	0	0
0	0	1	0	Off	Off	Off	Off	On	Off	Off	Off	0	0	0	0	C	0	0
1	0	1	0	Off	Off	Off	Off	Off	On	Off	Off	0	0	0	0	0	C	0
0	1	1	0	Off	Off	Off	Off	Off	Off	On	Off	0	0	0	0	0	0	C
1	1	1	0	Off	Off	Off	Off	Off	Off	Off	Reset	0	0	0	0	0	0	0
1	1	1	1	COIL OFF						0	0	0	0	0	0	0	0	

CONNECTOR PINOUT FOR LATCHING SP8T MULTI-THROW SWITCHES						
EXAMPLE	CCT-39S680-S	CCT-39S68C-S	CCT-39S680-TS	CCT-39S68C-TS	CCT-39S680-TDS	CCT-39S68C-TDS
INDICATOR		Yes		Yes		Yes
TTL			Yes	Yes		
Decoders & TTL					Yes	Yes
PIN NO.	15-PIN	26-PIN	15-PIN	26-PIN	15-PIN	26-PIN
1	PORT 1	PORT 1	TTL 1	TTL 1	LOGIC 1	LOGIC 1
2	PORT 2	PORT 2	TTL 2	TTL 2	LOGIC 2	LOGIC 2
3	PORT 3	PORT 3	TTL 3	TTL 3	LOGIC 3	LOGIC 3
4	PORT 4	PORT 4	TTL 4	TTL 4	LOGIC 4	LOGIC 4
5	PORT 5	PORT 5	TTL 5	TTL 5		
6	PORT 6	PORT 6	TTL 6	TTL 6		
7	PORT 7	PORT 7	TTL 7	TTL 7		
8	PORT 8	PORT 8	TTL 8	TTL 8		
9						
10						
11						
12						
13			Vsw	Vsw	Vsw	Vsw
14	Reset	Reset	Reset	Reset		
15	Common	Common	Common	Common	Common	Common
16		D Indicator (COM)		D Indicator (COM)		D Indicator (COM)
17		E Indicator		E Indicator		E Indicator
18		F Indicator		F Indicator		F Indicator
19		G Indicator		G Indicator		G Indicator
20		H Indicator		H Indicator		H Indicator
21		K Indicator		K Indicator		K Indicator
22		L Indicator		L Indicator		L Indicator
23		M Indicator		M Indicator		M Indicator
24		N Indicator		N Indicator		N Indicator
25						
26						

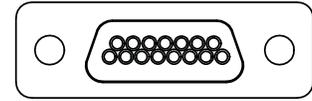

15-PIN D-SUB CONNECTOR

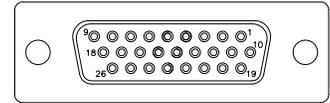

26-PIN D-SUB CONNECTOR

RF NOTES

Series CCT-39S
Multi-Throw DC-12 GHz, SP7T & SP8T
Latching Coaxial Switch, Internal 50Ω Termination



SP8T TRUTH TABLE Latching
CCT-39SX8C-T

Logic Input									RF Path									Indicator Switches							
1	2	3	4	5	6	7	8	R	J1	J2	J3	J4	J5	J6	J7	J8	Reset	E	F	G	H	K	L	M	N
1	0	0	0	0	0	0	0	0	On	Off	Off	Off	Off	Off	Off	Off	Off	C	0	0	0	0	0	0	0
0	1	0	0	0	0	0	0	0	Off	On	Off	Off	Off	Off	Off	Off	Off	0	C	0	0	0	0	0	0
0	0	1	0	0	0	0	0	0	Off	Off	On	Off	Off	Off	Off	Off	Off	0	0	C	0	0	0	0	0
0	0	0	1	0	0	0	0	0	Off	Off	Off	On	Off	Off	Off	Off	Off	0	0	0	C	0	0	0	0
0	0	0	0	1	0	0	0	0	Off	Off	Off	Off	On	Off	Off	Off	Off	0	0	0	0	C	0	0	0
0	0	0	0	0	1	0	0	0	Off	Off	Off	Off	Off	On	Off	Off	Off	0	0	0	0	0	C	0	0
0	0	0	0	0	0	1	0	0	Off	Off	Off	Off	Off	Off	On	Off	Off	0	0	0	0	0	0	C	0
0	0	0	0	0	0	0	1	0	Off	Off	Off	Off	Off	Off	Off	On	Off	0	0	0	0	0	0	0	C
0	0	0	0	0	0	0	0	1	Off	Off	Off	Off	Off	Off	Off	Off	On	0	0	0	0	0	0	0	C

TRUTH TABLE Latching
CCT-39SX8C-TD

Logic Input				RF Path							Indicator Switches										
1	2	3	4	J1	J2	J3	J4	J5	J6	J7	J8	Reset	E	F	G	H	K	L	M	N	
0	0	0	0	On	Off	Off	Off	Off	Off	Off	Off	Off	C	0	0	0	0	0	0	0	
1	0	0	0	Off	On	Off	Off	Off	Off	Off	Off	Off	0	C	0	0	0	0	0	0	
0	1	0	0	Off	Off	On	Off	Off	Off	Off	Off	Off	0	0	C	0	0	0	0	0	
1	1	0	0	Off	Off	Off	On	Off	Off	Off	Off	Off	0	0	0	C	0	0	0	0	
0	0	1	0	Off	Off	Off	Off	On	Off	Off	Off	Off	0	0	0	0	C	0	0	0	
1	0	1	0	Off	Off	Off	Off	Off	On	Off	Off	Off	0	0	0	0	0	C	0	0	
0	1	1	0	Off	Off	Off	Off	Off	Off	On	Off	Off	0	0	0	0	0	0	C	0	
1	1	1	0	Off	Off	Off	Off	Off	Off	Off	On	Off	0	0	0	0	0	0	0	C	
0	0	0	1	Off	Off	Off	Off	Off	Off	Off	Off	Reset	0	0	0	0	0	0	0	0	
1	1	1	1	COIL OFF							0	0	0	0	0	0	0	0	0	0	0

RF NOTES

TYPICAL RF PERFORMANCE CURVES

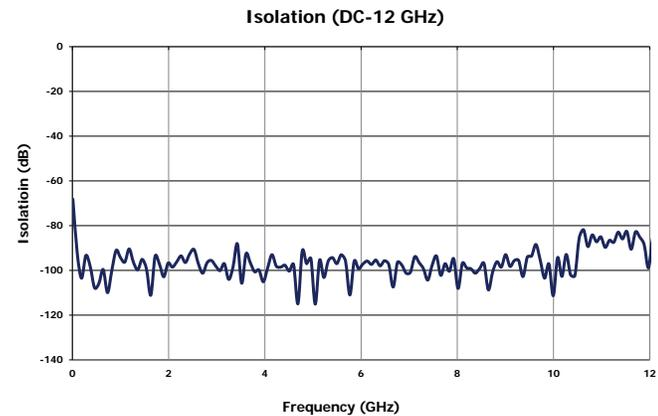
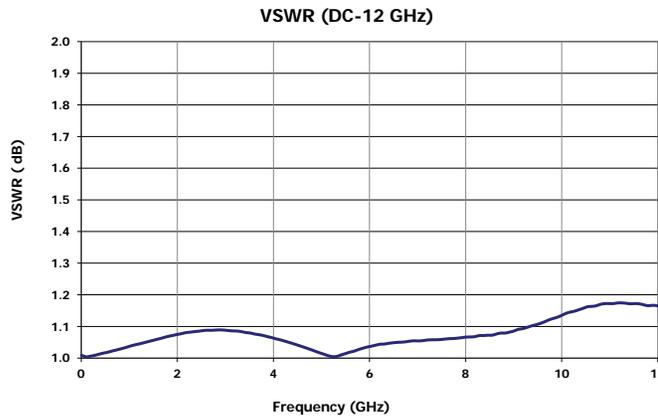
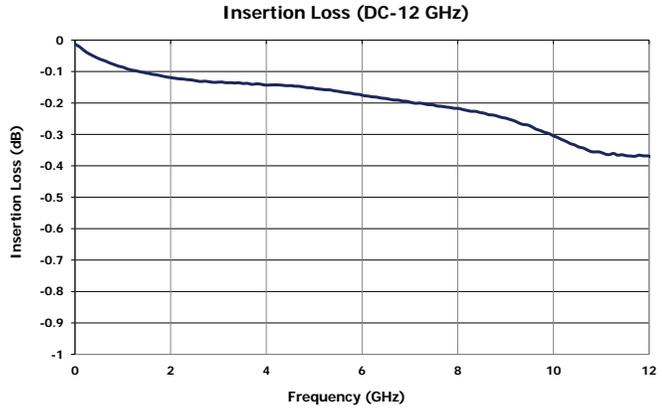

TYPICAL POWER PERFORMANCE CURVE

Power Handling vs. Frequency

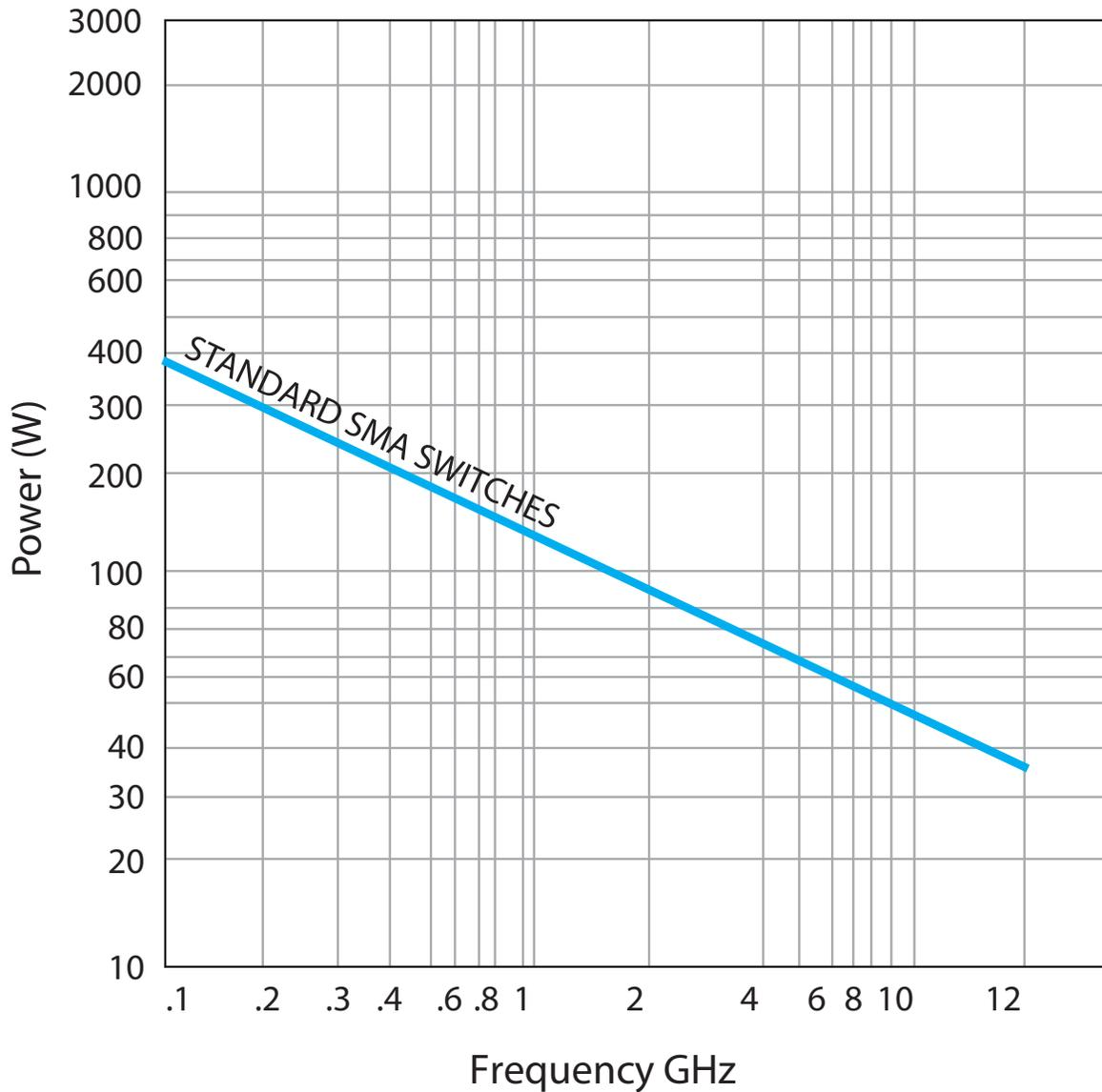

Estimates based on the following reference conditions:

- Ambient temperature of 40°C or less
- Sea level operation
- Load VSWR of 1.20:1 maximum
- No high-power (hot) switching

Please contact Teledyne Coax Switches for derating factors when applications do not meet the foregoing reference conditions.

GLOSSARY

Actuator

An actuator is the electromechanical mechanism that transfers the RF contacts from one position to another upon DC command.

Arc Suppression Diode

A diode is connected in parallel with the coil. This diode limits the “reverse EMF spike” generated when the coil de-energizes to 0.7 volts. The diode cathode is connected to the positive side of the coil and the anode is connected to the negative side.

Date Code

All switches are marked with either a unique serial number or a date code. Date codes are in accordance with MIL-STD-1285 Paragraph 5.2.5 and consist of four digits. The first two digits define the year and the last two digits define the week of the year (YYWW). Thus, 1032 identifies switches that passed through final inspection during the 32nd week of 2010.

Indicator

Indicators tell the system which position the switch is in. Other names for indicators are telemetry contacts or tellback circuit. Indicators are usually a set of internally mounted DC contacts linked to the actuator. They can be wired to digital input lines, status lights, or interlocks. Unless otherwise specified, the maximum indicator contact rating is 30 Vdc, 50 mA, or 1.5 Watts into a resistive load.

Isolation

Isolation is the measure of the power level at the output connector of an unconnected RF channel as referenced to the power at the input connector. It is specified in dB below the input power level.

Multi-Throw Latching Switch

A multi-throw switch is a switch with one input and three or more output ports. The CCT-39 can switch a microwave signal to any of 8 outputs from a single common input.

Switching Time

Switching time is the total interval beginning with the arrival of the leading edge of the command pulse at the switch DC input and ending with the completion of the switch transfer, including contact bounce. It consists of three parts: (1) inductive delay in the coil, (2) transfer time of the physical movement of the contacts, and (3) the bounce time of the RF contacts.

TTL Switch Driver Option

As a special option, switch drivers can be provided for both failsafe and latching switches, which are compatible with industry-standard low-power Schottky TTL circuits.

TD-Option

This option includes a decoder. The 3-bit parallel command is decoded to internally select the appropriate position. See the logic tables. The TD-Option increases the Vsw supply current demand by 50mA max at 28Vdc and +20°C.

Performance Parameters vs Frequency

Generally speaking, the RF performance of coaxial switches is frequency dependent. With increasing frequency, VSWR and insertion loss increase while isolation decreases. All data sheets specify these three parameters as “worst case” at the highest operating frequency. If the switch is to be used over a narrow frequency band, better performance can be achieved.

Actuator Current vs Temperature

The resistance of the actuator coil varies as a function of temperature. There is an inverse relationship between the operating temperature of the switch and the actuator drive current. For switches operating at 28 VDC, the approximate actuator drive current at temperature, T, can be calculated using the equation:

$$I_T = \frac{I_A}{[1 + .00385 (T-20)]}$$

Where:

I_T = Actuator current at temperature, T

I_A = Room temperature actuator current – see data sheet

T = Temperature of interest in °C

Magnetic Sensitivity

An electro-mechanical switch can be sensitive to ferrous materials and external magnetic fields. Neighboring ferrous materials should be permitted no closer than 0.5 inches and adjacent external magnetic fields should be limited to a flux density of less than 5 Gauss.

SPECIAL FEATURE

Switching High-Power or Highly Sensitive Signals

Ensure the most linear response with the best galvanically matched contact system in the industry. Extremely low passive intermodulation is standard on all of our switches.

Carrier Frequency 1	Carrier Frequency 2	PIM 3rd Order Frequency	PIM 5th Order Frequency
870 MHz	893 MHz	847 MHz	824 MHz

	3rd Order Intermodulation	5th Order Intermodulation
Multiple Positions	-96 dBm	-115 dBm
	-139 dBc	-158 dBc

Series CCT-39S

Multi-Throw DC-12 GHz, SP7T & SP8T
Latching Coaxial Switch, Internal 50Ω Termination



LATCHING CCT-39S PART NUMBER LIST

	PART No.		PART No.		PART No.
1	CCT-39SX7C	43	CCT-39SX70-TMS	85	CCT-39SX80-TDS
2	CCT-39SX7C-D	44	CCT-39SX70-TS	86	CCT-39SX80-TM
3	CCT-39SX7C-DM	45	CCT-39SX8C	87	CCT-39SX80-TMS
4	CCT-39SX7C-DR	46	CCT-39SX8C-D	88	CCT-39SX80-TS
5	CCT-39SX7C-DRM	47	CCT-39SX8C-DM		
6	CCT-39SX7C-DRS	48	CCT-39SX8C-DR		
7	CCT-39SX7C-DS	49	CCT-39SX8C-DRM		
8	CCT-39SX7C-M	50	CCT-39SX8C-DRS		
9	CCT-39SX7C-MS	51	CCT-39SX8C-DS		
10	CCT-39SX7C-R	52	CCT-39SX8C-M		
11	CCT-39SX7C-RM	53	CCT-39SX8C-MS		
12	CCT-39SX7C-RMS	54	CCT-39SX8C-R		
13	CCT-39SX7C-RS	55	CCT-39SX8C-RM		
14	CCT-39SX7C-S	56	CCT-39SX8C-RMS		
15	CCT-39SX7C-T	57	CCT-39SX8C-RS		
16	CCT-39SX7C-TD	58	CCT-39SX8C-S		
17	CCT-39SX7C-TDM	39	CCT-39SX8C-T		
18	CCT-39SX7C-TDMS	60	CCT-39SX8C-TD		
19	CCT-39SX7C-TDS	61	CCT-39SX8C-TDM		
20	CCT-39SX7C-TM	62	CCT-39SX8C-TDMS		
21	CCT-39SX7C-TMS	63	CCT-39SX8C-TDS		
22	CCT-39SX7C-TS	64	CCT-39SX8C-TM		
23	CCT-39SX70	65	CCT-39SX8C-TMS		
24	CCT-39SX70-D	66	CCT-39SX8C-TS		
25	CCT-39SX70-DM	67	CCT-39SX80		
26	CCT-39SX70-DR	68	CCT-39SX80-D		
27	CCT-39SX70-DRM	69	CCT-39SX80-DM		
28	CCT-39SX70-DRS	70	CCT-39SX80-DR		
29	CCT-39SX70-DS	71	CCT-39SX80-DRM		
30	CCT-39SX70-M	72	CCT-39SX80-DRS		
31	CCT-39SX70-MS	73	CCT-39SX80-DS		
32	CCT-39SX70-R	74	CCT-39SX80-M		
33	CCT-39SX70-RM	75	CCT-39SX80-MS		
34	CCT-39SX70-RMS	76	CCT-39SX80-R		
35	CCT-39SX70-RS	77	CCT-39SX80-RM		
36	CCT-39SX70-S	78	CCT-39SX80-RMS		
37	CCT-39SX70-T	79	CCT-39SX80-RS		
38	CCT-39SX70-TD	80	CCT-39SX80-S		
39	CCT-39SX70-TDM	81	CCT-39SX80-T		
40	CCT-39SX70-TDMS	82	CCT-39SX80-TD		
41	CCT-39SX70-TDS	83	CCT-39SX80-TDM		
42	CCT-39SX70-TM	84	CCT-39SX80-TDMS		

* X = 6 (28Vdc), 7 (15Vdc), 8 (12Vdc) and 9 (24Vdc)