

Part Number*	Description
KD00CK	5A Solid State Relay
KD02CK	5A SSR with Switch Status
KD20CK	5A SSR with Short Circuit Protection
KD22CK	5A SSR with Short Circuit Protection and Switch Status
LD00CM	10A Solid State Relay
LD02CM	10A SSR with Switch Status
LD20CM	10A SSR with Short Circuit Protection
LD22CM	10A SSR with Short Circuit Protection and Switch Status

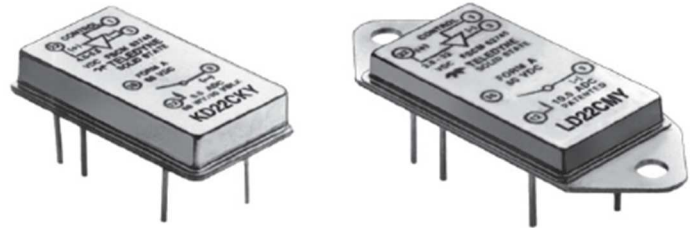

*The Y suffix denotes parameters tested to MIL-PRF-28750 Specifications.
 The W suffix denotes parameters tested to Teledyne Specifications.

ELECTRICAL SPECIFICATIONS

(-55°C to +105°C UNLESS OTHERWISE NOTED)

INPUT (CONTROL) SPECIFICATIONS

When used in 2 terminal configuration

(TTL or direct control) (See Fig. 1)	Min	Typ	Max	Units
Input Current @ $V_{BIAS} = 5 V_{DC}$ (See Fig 2)			15	mA
Turn-Off Voltage (Guaranteed Off)			1.5	V_{DC}
Turn-On Voltage (Guaranteed On)	3.8			V_{DC}
Reverse Voltage Protection			-32	V_{DC}
Input Supply Range (See Note 1, 7)	3.8		16	V_{DC}

INPUT (CONTROL) SPECIFICATIONS

When used in 3 terminal configuration

(CMOS or open collector TTL)	Min	Typ	Max	Units
Control Current				
$V_{CONTROL} = 5 V_{DC}$			250	μA_{DC}
$V_{CONTROL} = 18 V_{DC}$ (See Note 7)			1.0	mA_{DC}
Control Voltage Range (See Note 7)	0		18	V_{DC}
Bias Supply Voltage (See Note 1, 7)	3.8		32	V_{DC}
Bias Supply Current @ $V_{BIAS} = 5 V_{DC}$			16	mA
Control Turn-Off Voltage (Guaranteed Off)	3.2			V_{DC}
Control Turn-On Voltage (Guaranteed On)		0.3		V_{DC}

ENVIRONMENTAL SPECIFICATIONS

	Min	Max	Units
Temperature Range			
Operating	-55	+125	°C
Storage	-55	+125	°C
Vibration, 100 g	10	3000	Hz
Constant Acceleration		5000	g
Shock, 0.5 ms pulse		1500	g

FEATURES

- Available with short-circuit/current overload protection
- Available with switch status output
- TTL and CMOS compatible control
- Low ON resistance power FET output
- Fast switching speed
- Meets 28 Vdc system requirements of MIL-STD-704
- Optical isolation
- Low profile hermetic package
- Built and tested to the requirements of MIL-PRF-28750

DESCRIPTION

The Series KD and LD solid-state relays are screened utilizing MIL-PRF-28750 test methods and are packaged in low profile hermetically sealed cases. These relays are constructed with state-of-the-art solid state techniques and feature fully floating power FET output technology. This allows the load to be connected to either output terminal and provides a low ON resistance. The input (control) and output are optically isolated to protect input logic circuits from output transients. Available options include short circuit and current overload protection, which provides complete protection for both the relay and system wiring. This feature not only provides protection should a short or overload occur while the relay is on, but will also provide protection should the relay be switched into a short. The second option is a status output line. Switch status returns the true status of the output switch and is optically isolated from the load. It provides status indication independent of the control circuit of the relay. The status line provides a logic 0 (low) when the relay output is off with load voltage and continuity present, and a logic 1 (high) when the output is on.

ELECTRICAL SPECIFICATIONS, CONT.

(-55°C to +105°C UNLESS OTHERWISE NOTED)

OUTPUT (LOAD) SPECIFICATIONS

(See Note 2)	Min	Typ	Max	Units
Continuous Load Current (See Fig. 3) KD and LD without heatsink			5	A _{DC}
LD series with heatsink			10	A _{DC}
Leakage Current @ V _{LOAD} = 60 V _{DC}				
KD00CK, KD20CK			100	µA
LD00CM, LD20CM			100	µA
KD02CK, KD22CK			2	mA
LD02CM, LD22CM			2	mA
Output Voltage Drop				
KD00CK, KD20CK			0.6	V _{DC}
LD00CM, LD20CM			0.7	V _{DC}
KD02CK, KD22CK @ 10A			1.2	V _{DC}
LD02CM, LD22CM @ 10A			1.4	V _{DC}
Continuous Operating Load Voltage	5		60	V _{DC}
Transient Blocking Voltage @ 25°C			80	V _{pk}
ON Resistance R _{ds} (on) (See Fig 4)				
KD00CK, KD20CK			.075	Ω
LD00CM, LD20CM			.075	Ω
KD02CK, KD22CK			.100	Ω
LD02CM, LD22CM			.100	Ω
Turn-On Time (See Fig. 5)			5	mS
Turn-Off Time (See Fig. 5)			2	mS
Electrical System Spike (See Note 7)			±600	V _{DC}
Output Capacitance at 25 Vdc, 100 KHz (See Note 7)			1600	pF
Isolation (Input to Output) (See Note 7)				
KD00CK, KD20CK			10	pF
LD00CM, LD20CM			10	pF
KD02CK, KD22CK			15	pF
LD02CM, LD22CM			15	pF
Dielectric Strength @ 25°C	1000			V _{AC}
Insulation Resistance @ 500V _{DC} @ 25°C	10 ⁹			Ω
Output Junction Temperature @ I _{LOAD} = I _{max rated}			130	°C
Maximum Junction Temperature			150	°C
Thermal Resistance Junction to Ambient (θ _{JA})			30	°C/W
Thermal Resistance Junction to Case (θ _{JC})			7	°C/W

NOTES:

- Control input is compatible with CMOS or open collector TTL (with pull up resistor). For bias voltages above 6V, a series resistor is required. Use the standard resistor value equal to or less than the value found in Figure 8.
- The rated input voltage is 5V for all tests unless otherwise specified.
- To calculate the maximum ON resistance for a given junction temperature, find the normalized ON resistance factor (NR) from Figure 4. Calculate the new ON resistance as follows:
 $R_{(ON)} = NR \cdot R_{ON @ 25^\circ C}$ (for KD00CK, LD00CM, KD02CK, LD02CM)
 $R_{(ON)} = NR(R_{ON @ +25^\circ C}) + .025 \text{ ohm}$ (for KD20CK, LD20CM, KD22CK, LD22CM)

BLOCK DIAGRAMS

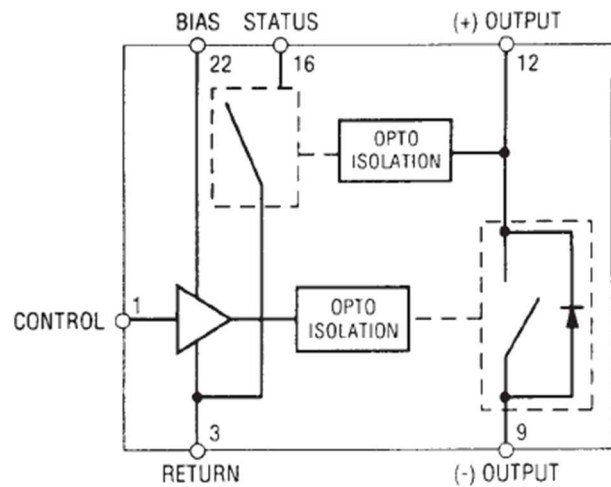

WITH STATUS

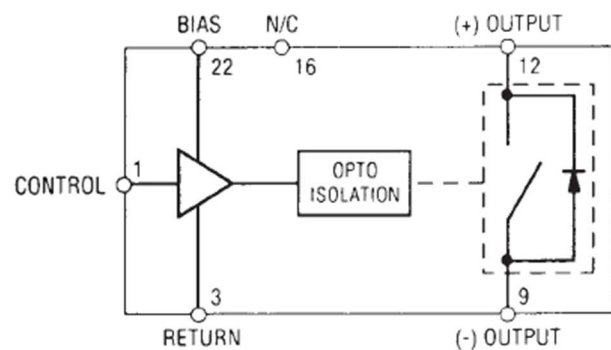

NO STATUS

STATUS OUTPUT TRUTH TABLE

(KD02CK, LD02CM, KD22CK, LD22CM)

Control Voltage	Relay Output	State Status Output Level
High	Off	Low (V _{SO} ≤ 0.4 V)
Low	On	High (V _{SO} = V _{STATUS})

STATUS OUTPUT SPECIFICATIONS

(KD02CK, LD02CM, KD22CK, LD22CM)

	Min	Typ	Max	Units
Status Supply Voltage			30	V _{DC}
Status Leakage Current @ 16V _{DC}			10	µA _{DC}
@ 30V _{DC}			100	µA _{DC}
Status (sink) Current (V _{SO} < 0.4 Vdc)			600	µA _{DC}
Status Turn-On Time (See Fig. 6)			3.5	ms
Status Turn-Off Time (See Fig. 6)			8.0	ms

MECHANICAL SPECIFICATION

Dimensions are shown in inches (mm)

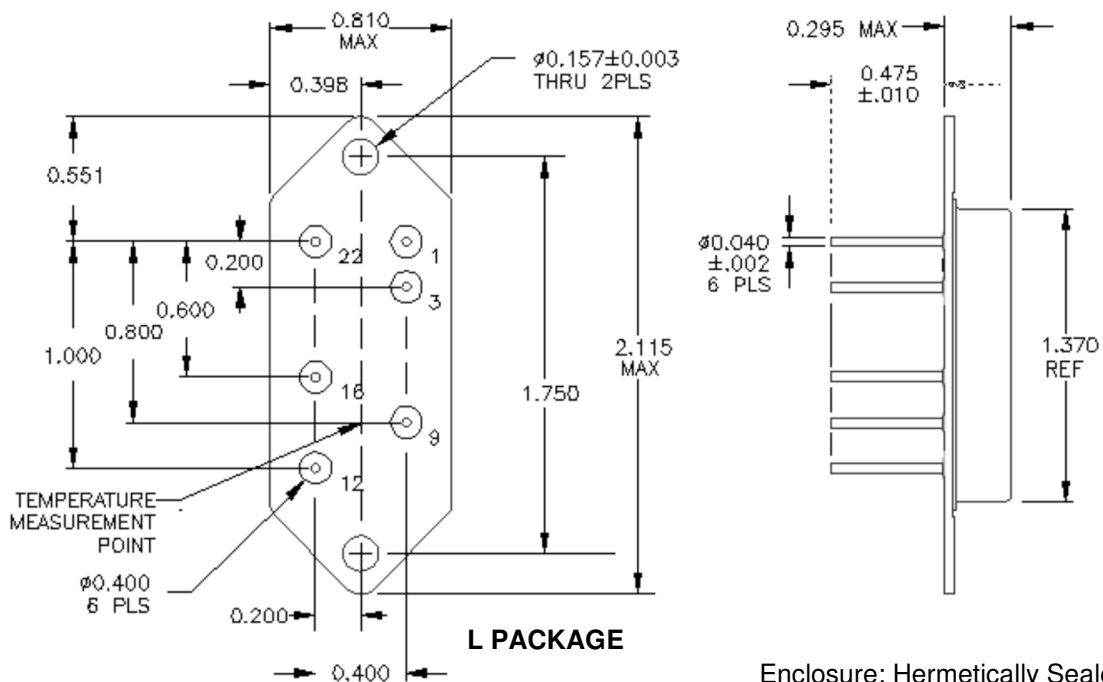
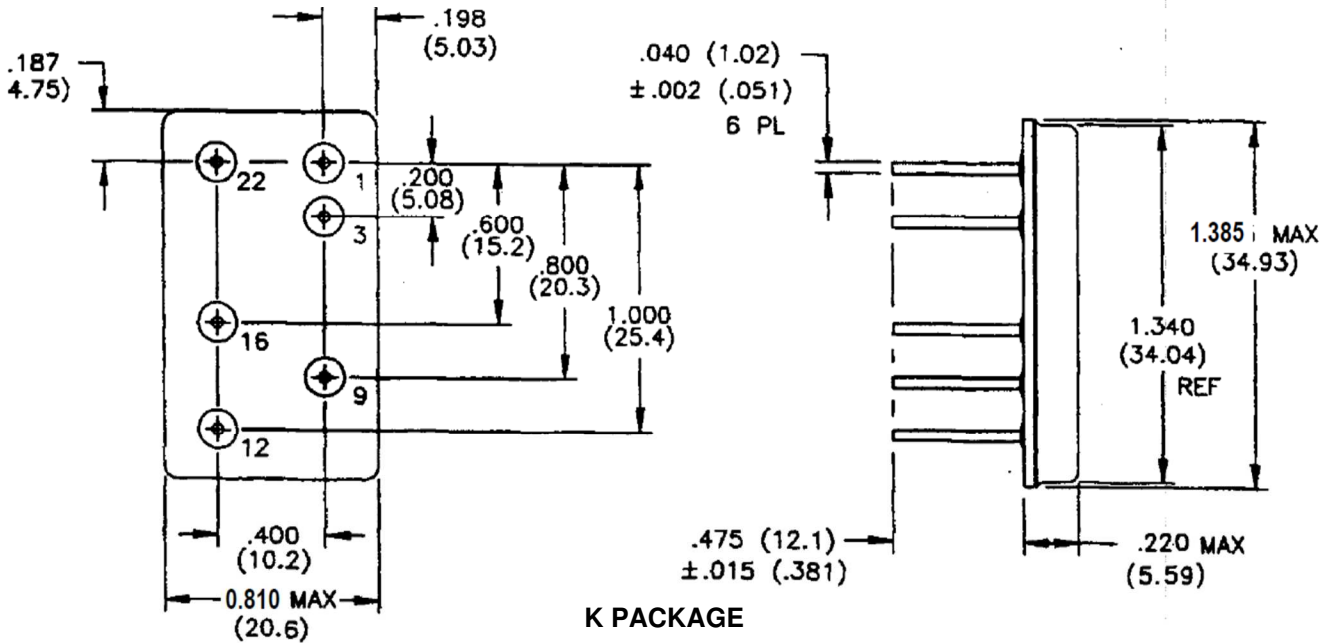

NOTES, CONT.:

- Overload testing to the requirements of MIL-PRF-28750 is constrained to the limits imposed by the short circuit protection characteristics as defined in this specification. System series inductance for "shorted-load" mode of operation should be 50 μ H. Maximum repetition rate into a shorted load should not exceed 10 Hz.
- A status pull up resistor is required for proper operation of the status output. Determine the current (I_{so}) required by the status interface. Calculate the current (I_s) through the status resistor such that the sink current through the status output is 0.6 mA. Select the status resistor such that it does not allow more than 0.6 mA to flow through the status output. $R_{STATUS} = (V_{STATUS} - 0.4V) / I_{so}$
- Inductive loads should be diode suppressed. Input transitions should be ≤ 1 ms duration and the input drive should be a bounceless contact type.
- Parameter Guaranteed by design, but not tested 100% in product acceptance.

Enclosure: Hermetically Sealed DIP
 Leak Rate: 1×10^{-6} cc/s Max
 Material: Header: Cold Rolled Steel
 Nickel Plated
 Pins: Copper Core
 Cover: Grade A Nickel
 Weight: 20 grams
 Tolerance: .XXX ± .005

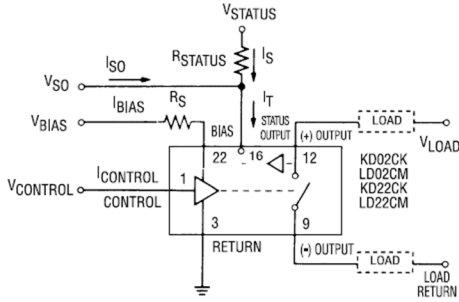

(A) 3 Terminal Input with Status (See Note 5)

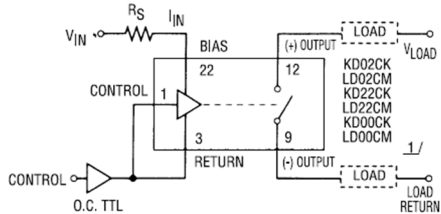

(B) 2 Terminal Input (Open Collector TTL Drive)

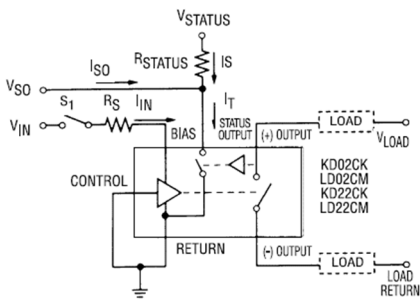

(C) 2 Terminal Input (Direct Drive) with Status

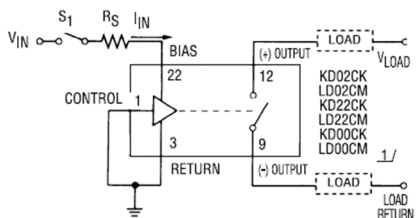

(D) 2 Terminal Input (Direct Drive)

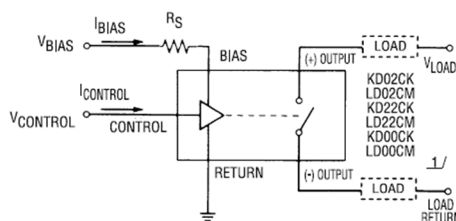

1/ KD02CK, KD22CK, LD02CM and LD22CM may be wired without the status line as shown in (B), (D) and (E) above.

(E) 3 Terminal Input without Status

**WIRING CONFIGURATIONS
FIGURE 1 (See Note 1)**

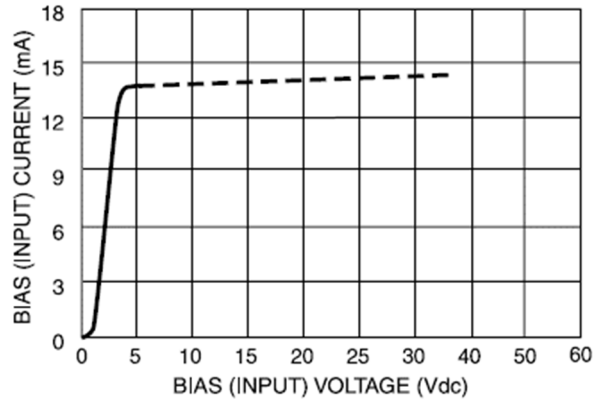

**BIAS (INPUT) CURRENT VS BIAS (INPUT) VOLTAGE
FIGURE 2 (See Note 1)**

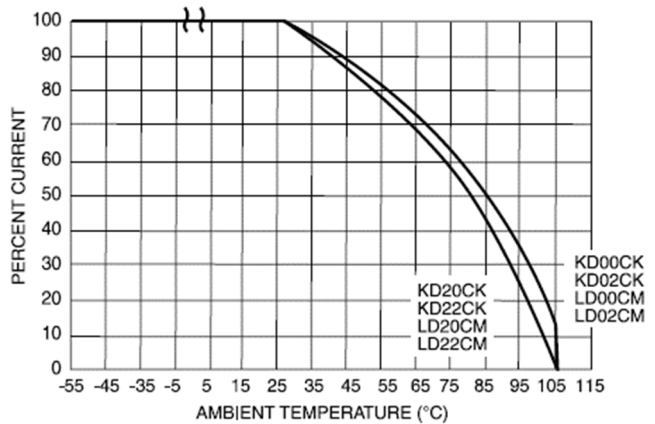

**LOAD CURRENT DERATING CURVE FOR KD/LD SERIES
WITHOUT A HEAT SINK
(A)**

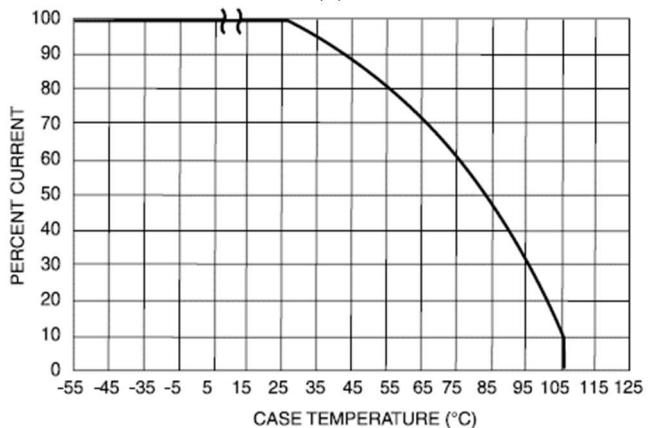

**LOAD CURRENT DERATING CURVE FOR LD SERIES
WITH HEAT SINK
(B)**

**THERMAL DERATING CURVES
FIGURE 3**

DATA PRESENTED IS TYPICAL - FOR REFERENCE ONLY

For application assistance contact relays@teledyne.com or (800) 284-7007

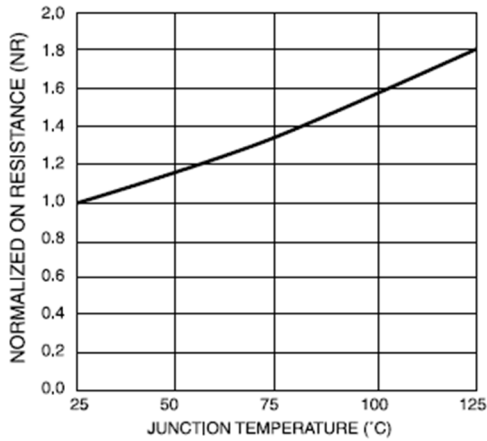

NORMALIZED ON RESISTANCE VS JUNCTION TEMPERATURE
FIGURE 4 (See Note 3)

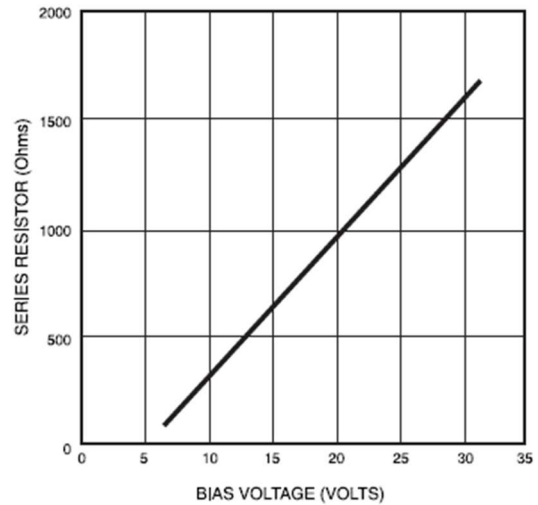

SERIES LIMIT BIAS RESISTOR VS BIAS VOLTAGE
FIGURE 8 (See Note 1)

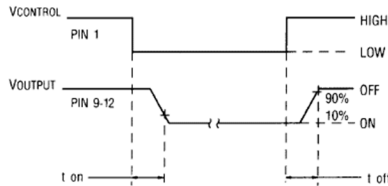

OUTPUT TURN-ON AND TURN-OFF TIMING
FIGURE 5

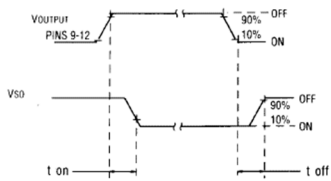

STATUS TURN-ON AND TURN-OFF TIMING
FIGURE 6

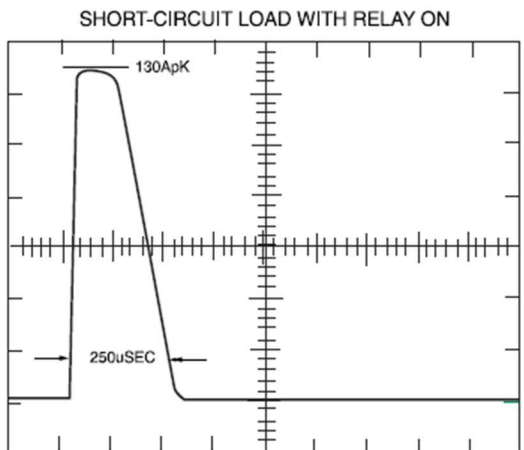
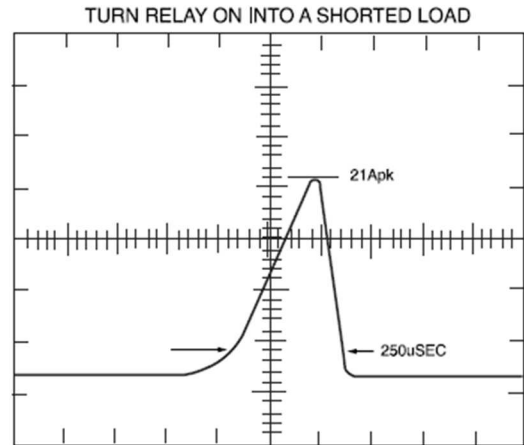

TYPICAL TRIP CURRENT CHARACTERISTICS FOR SHORT CIRCUIT CONDITIONS
FIGURE 9

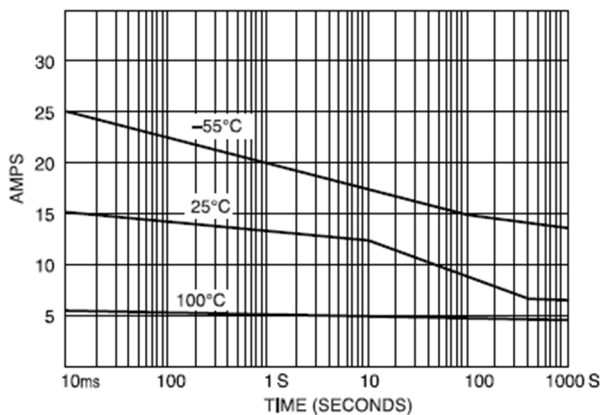

OVERLOAD CURRENT VS TIME TO TRIP (TYPICAL)
KD20CK, KD22CK, LD20CM, LD22CM
FIGURE 7

DATA PRESENTED IS TYPICAL - FOR REFERENCE ONLY

For application assistance contact relays@teledyne.com or (800) 284-7007