

Features

2018

- ◆ Low forward voltage drop
- ◆ High current capability
- ◆ High reliability
- ◆ High surge current capability



R-1

Mechanical Data

- ◆ Case: Molded plastic R-1
- ◆ Epoxy: UL 94V-O rate flame retardant
- ◆ Lead: Axial leads, solderable per MIL-STD-202, Method 208 guaranteed
- ◆ Polarity: Color band denotes cathode end
- ◆ High temperature soldering guaranteed:
250°C/10 seconds .375" (9.5mm) lead lengths at 5 lbs., (2.3kg) tension
- ◆ Mounting position: Any
- ◆ Weight: 0.007 ounce, 0.20 gram

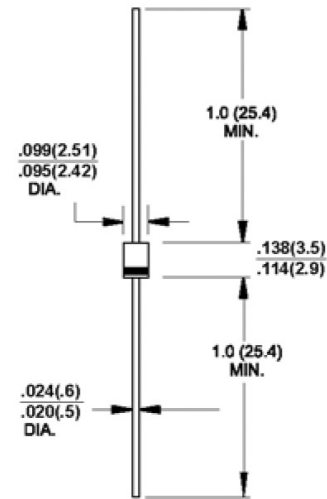

Maximum Ratings and Electrical Characteristics

Ratings at 25°C ambient temperature unless otherwise specified.

Single phase, half wave, 60Hz, resistive or inductive load.

For capacitive load, derate current by 20%

Parameter	Symbols	1F1G	1F2G	1F3G	1F4G	1F5G	1F6G	1F7G	Units
Maximum repetitive peak reverse voltage	V_{RRM}	50	100	200	400	600	800	1000	Volts
Maximum RMS voltage	V_{RMS}	35	70	140	280	420	560	700	Volts
Maximum DC blocking voltage	V_{DC}	50	100	200	400	600	800	1000	Volts
Maximum average forward rectified current 0.375" (9.5mm) lead length at $T_A=30^\circ\text{C}$	I_{AV}	1.0							Amp
Peak forward surge current, 8.3 ms single half sine-wave superimposed on rated load (JEDEC Method)	I_{FSM}	30.0							Amps
Maximum instantaneous forward voltage @ 1.0A	V_F	1.3							Volts
Maximum DC reverse current at rated DC blocking voltage	I_R	5.0 100							μA
Maximum reverse recovery time (Note 1)	t_{rr}	150				250	500		nS
Typical junction capacitance (Note 2)	C_J	12							pF
Operating junction temperature range	T_J	-55 to +150							°C
Storage temperature range	T_{STG}	-55 to +150							°C

- Notes:**
1. Reverse Recovery Test Conditions: $I_F=0.5\text{A}$, $I_R=1.0\text{A}$, $I_{RR}=0.25\text{A}$
 2. Measured at 1 MHz and Applied Reverse Voltage of 4.0 V D.C.

RATINGS AND CHARACTERISTIC CURVES

FIG.1- REVERSE RECOVERY TIME CHARACTERISTIC AND TEST CIRCUIT DIAGRAM

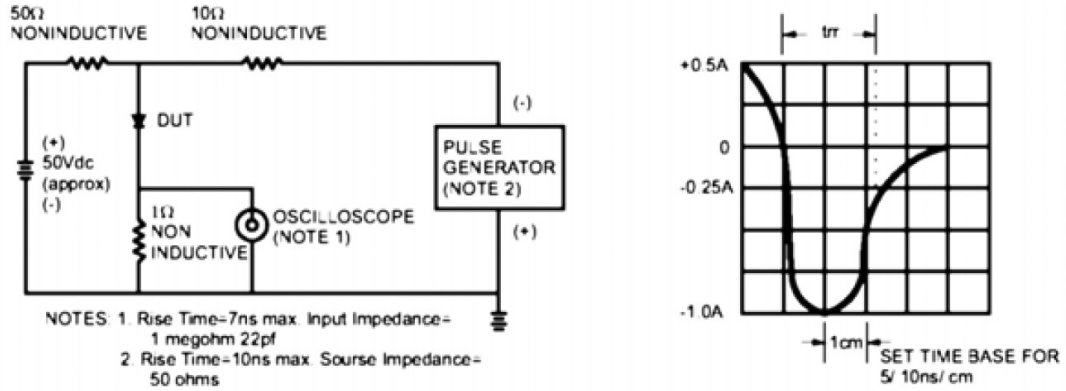

FIG.2- MAXIMUM FORWARD CURRENT DERATING CURVE

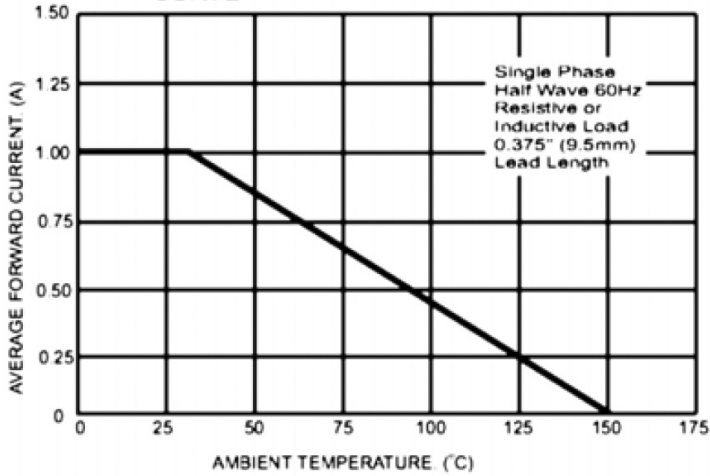

FIG.3- MAXIMUM NON-REPETITIVE FORWARD SURGE CURRENT

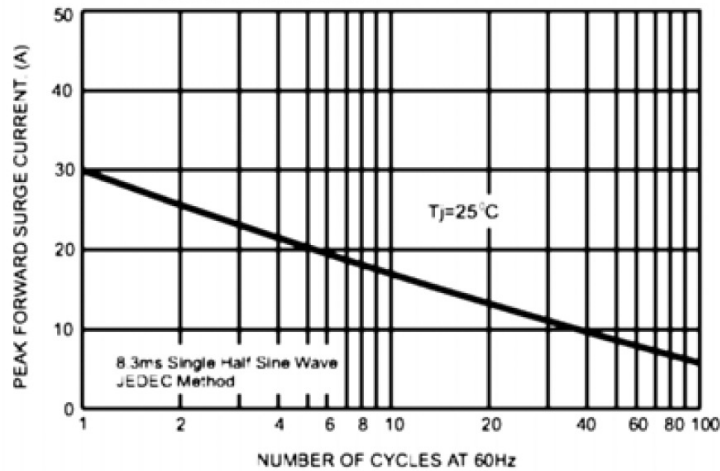

FIG.4- TYPICAL JUNCTION CAPACITANCE

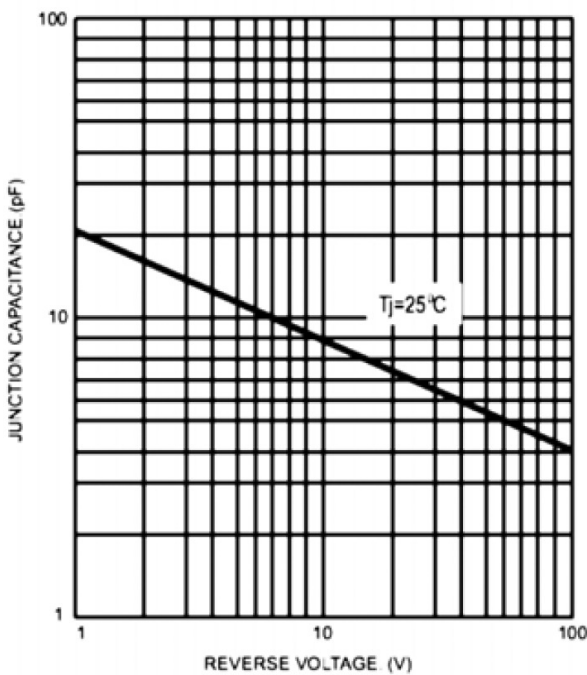

FIG.5- TYPICAL FORWARD CHARACTERISTICS

