

36DA

Vishay Sprague



Aluminum Capacitors + 85 °C and + 95 °C, Large Can

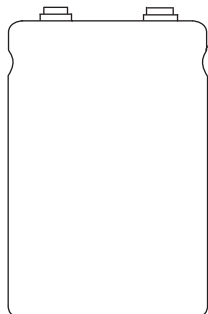

Fig.1 Component Outlines

FEATURES

- The industry standard for large can aluminum capacitors
- Ideal for high wattage power supplies and energy storage applications
- Largest capacitance available
- Highest voltage available
- Metric threads and stud mount versions included
- Replaces type 36DY
- Screw terminal
- Compliant to RoHS directive 2002/95/EC

RoHS
COMPLIANT

QUICK REFERENCE DATA	
DESCRIPTION	VALUE
Nominal case size Ø D x L in inches (mm)	1.375 x 1.625 (35.0 x 41.2) to 3.000 x 8.675 (76.2 x 220.3)
Operating temperature	- 40 °C to + 95 °C: 6.3 WVDC to 100 WVDC; - 40 °C to + 85 °C; 125 WVDC to 500 WVDC
Rated capacitance range, C _R	100 µF to 2.2 F
Tolerance on C _R	- 10 % to 50 %
Rated voltage range, U _R	6.3 WVDC to 500 WVDC
Termination	Screw insert or solderable terminals
Life validation test at 85 °C	2000 h: ΔCAP ≤ 15 % from initial measurement ΔESR ≤ 1.5 x initial specified limit
Shelf life at 85 °C	500 h: ΔCAP ≤ 15 % from initial measurement ΔESR ≤ 1.2 x initial specified limit
DC leakage current 5 min charge time	$I = K\sqrt{CV}$ K = 4.0 at + 25 °C; 32.0 at + 85 °C I in A, C in F, V in Volts

RIPPLE CURRENT MULTIPLIERS			
TEMPERATURE			
AMBIENT TEMPERATURE	MULTIPLIERS		
+ 85 °C	1.0		
+ 75 °C	1.4		
+ 65 °C	1.7		
+ 55 °C and below	2.0		
FREQUENCY (Hz)			
RATED WVDC	120	400	1000 AND UP
0 to 50	1.0	1.05	1.10
51 to 100	1.0	1.10	1.15
150 to 300	1.0	1.15	1.25
301 to 500	1.0	1.20	1.30

DIMENSIONS in inches (millimeters)							
LARGE CAN CAPACITORS							
CASE CODE	NOMINAL		WITH INSULATING SLEEVE			TERMINAL SPACING M ± 0.016 (0.4)	TYPICAL WEIGHT (g)
	D ± 0.032 (0.8)	L ± 0.063 (1.6)	D (Max.)	L (Max.)	(P TERMINAL) H (Max.)		
AN	1.375 (35.0)	1.625 (41.0)	1.453 (36.9)	1.750 (44.5)	1.849 (47.0)	0.500 (12.7)	43.0
AY	1.375 (35.0)	1.875 (48.0)	1.453 (36.9)	2.000 (50.8)	1.099 (53.3)	0.500 (12.7)	54.0
AA	1.375 (35.0)	2.125 (54.0)	1.453 (36.9)	2.250 (57.2)	1.349 (59.7)	0.500 (12.7)	63.0
AM	1.375 (35.0)	2.625 (67.0)	1.453 (36.9)	2.750 (69.9)	1.849 (72.4)	0.500 (12.7)	82.0
AB	1.375 (35.0)	3.125 (79.0)	1.453 (36.9)	3.250 (82.6)	1.349 (85.1)	0.500 (12.7)	105.0
AL	1.375 (35.0)	3.625 (92.0)	1.453 (36.9)	3.750 (95.3)	1.849 (97.8)	0.500 (12.7)	122.0



Aluminum Capacitors
+ 85 °C and + 95 °C, Large Can

Vishay Sprague

DIMENSIONS in inches (millimeters)							
LARGE CAN CAPACITORS							
CASE CODE	NOMINAL		WITH INSULATING SLEEVE			TERMINAL SPACING M ± 0.016 (0.4)	TYPICAL WEIGHT (g)
	D ± 0.032 (0.8)	L ± 0.063 (1.6)	D (Max.)	L (Max.)	(P TERMINAL) H (Max.)		
AC	1.375 (35.0)	4.125 (105.0)	1.453 (36.9)	4.250 (108.0)	1.349 (110.5)	0.500 (12.7)	129.0
AD	1.375 (35.0)	4.625 (117.0)	1.453 (36.9)	4.750 (120.7)	1.849 (123.2)	0.500 (12.7)	162.0
AE	1.375 (35.0)	5.125 (130.0)	1.453 (36.9)	5.250 (133.4)	1.349 (125.9)	0.500 (12.7)	179.0
AF	1.375 (35.0)	5.625 (143.0)	1.453 (36.9)	5.750 (146.1)	1.849 (148.6)	0.500 (12.7)	201.0
EN	1.750 (44.0)	1.625 (41.0)	1.828 (46.4)	1.750 (44.5)	1.849 (47.0)	0.750 (19.1)	71.0
EY	1.750 (44.0)	1.875 (48.0)	1.828 (46.4)	2.000 (50.8)	2.099 (53.3)	0.750 (19.1)	88.0
EA	1.750 (44.0)	2.125 (54.0)	1.828 (46.4)	2.250 (57.2)	2.349 (59.7)	0.750 (19.1)	102.0
EM	1.750 (44.0)	2.625 (67.0)	1.828 (46.4)	2.750 (69.9)	2.849 (72.4)	0.750 (19.1)	133.0
EB	1.750 (44.0)	3.125 (79.0)	1.828 (46.4)	3.250 (82.6)	3.349 (85.1)	0.750 (19.1)	167.0
EL	1.750 (44.0)	3.625 (92.0)	1.828 (46.4)	3.750 (95.3)	3.849 (97.8)	0.750 (19.1)	198.0
EC	1.750 (44.0)	4.125 (105.0)	1.828 (46.4)	4.250 (108.0)	4.349 (110.5)	0.750 (19.1)	230.0
ED	1.750 (44.0)	4.625 (117.0)	1.828 (46.4)	4.750 (120.7)	4.849 (123.2)	0.750 (19.1)	252.0
EE	1.750 (44.0)	5.125 (130.0)	1.828 (46.4)	5.250 (133.4)	5.349 (135.9)	0.750 (19.1)	269.0
EF	1.750 (44.0)	5.625 (143.0)	1.828 (46.4)	5.750 (146.1)	5.849 (148.6)	0.750 (19.1)	318.0
BY	2.000 (51.0)	1.875 (48.0)	2.078 (52.8)	2.000 (50.8)	2.099 (53.3)	0.875 (22.2)	113.0
BA	2.000 (51.0)	2.125 (54.0)	2.078 (52.8)	2.250 (57.2)	2.349 (59.7)	0.875 (22.2)	133.0
BM	2.000 (51.0)	2.625 (67.0)	2.078 (52.8)	2.750 (69.9)	2.849 (72.4)	0.875 (22.2)	176.0
BB	2.000 (51.0)	3.125 (79.0)	2.078 (52.8)	3.250 (82.6)	3.349 (85.1)	0.875 (22.2)	213.0
BL	2.000 (51.0)	3.625 (92.0)	2.078 (52.8)	3.750 (95.3)	3.849 (97.8)	0.875 (22.2)	261.0
BC	2.000 (51.0)	4.125 (105.0)	2.078 (52.8)	4.250 (108.0)	4.349 (110.5)	0.875 (22.2)	381.0
BD	2.000 (51.0)	4.625 (117.0)	2.078 (52.8)	4.750 (120.7)	4.849 (123.2)	0.875 (22.2)	326.0
BE	2.000 (51.0)	5.125 (130.0)	2.078 (52.8)	5.250 (133.4)	5.349 (135.9)	0.875 (22.2)	337.0
BF	2.000 (51.0)	5.625 (143.0)	2.078 (52.8)	5.750 (146.1)	5.849 (148.6)	0.875 (22.2)	408.0
CB	2.500 (64.0)	3.125 (79.0)	2.578 (65.5)	3.250 (82.6)	N/A	1.125 (28.6)	329.0
CL	2.500 (64.0)	3.625 (92.0)	2.578 (65.5)	3.750 (95.3)	N/A	1.125 (28.6)	400.0
CC	2.500 (64.0)	4.125 (105.0)	2.578 (65.5)	4.250 (108.0)	N/A	1.125 (28.6)	473.0
CD	2.500 (64.0)	4.625 (117.0)	2.578 (65.5)	4.750 (120.7)	N/A	1.125 (28.6)	562.0
CE	2.500 (64.0)	5.125 (130.0)	2.578 (65.5)	5.250 (133.4)	N/A	1.125 (28.6)	607.0
CF	2.500 (64.0)	5.625 (143.0)	2.578 (65.5)	5.750 (146.1)	N/A	1.125 (28.6)	675.0
DB	3.000 (76.0)	3.125 (79.0)	3.078 (78.2)	3.250 (82.6)	N/A	1.250 (31.8)	496.0
DL	3.000 (76.0)	3.625 (92.0)	3.078 (78.2)	3.750 (95.3)	N/A	1.250 (31.8)	598.0
DC	3.000 (76.0)	4.125 (105.0)	3.078 (78.2)	4.250 (108.0)	N/A	1.250 (31.8)	700.0
DD	3.000 (76.0)	4.625 (117.0)	3.078 (78.2)	4.750 (120.7)	N/A	1.250 (31.8)	802.0
DE	3.000 (76.0)	5.125 (130.0)	3.078 (78.2)	5.250 (133.4)	N/A	1.250 (31.8)	944.0
DF	3.000 (76.0)	5.625 (143.0)	3.078 (78.2)	5.750 (146.1)	N/A	1.250 (31.8)	1004.0
DJ	3.000 (76.0)	8.625 (219.0)	3.078 (78.2)	8.750 (222.3)	N/A	1.250 (31.8)	1403.0

36DA

Vishay Sprague

Aluminum Capacitors
+ 85 °C and + 95 °C, Large Can



DIMENSIONS AND AVAILABLE FORMS

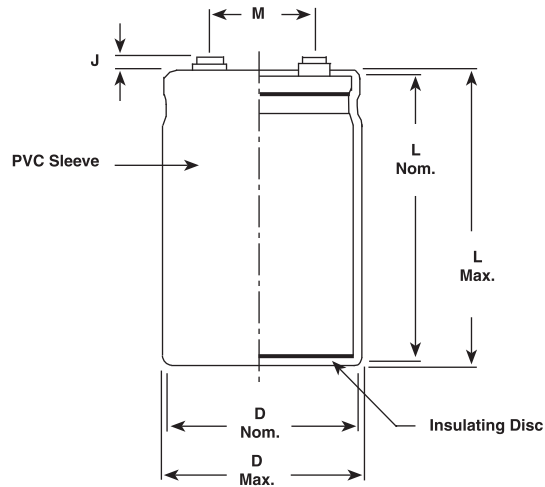
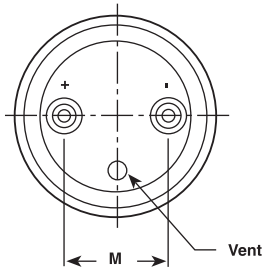

Stud Mount Option for Large Can Capacitors (Special Order)

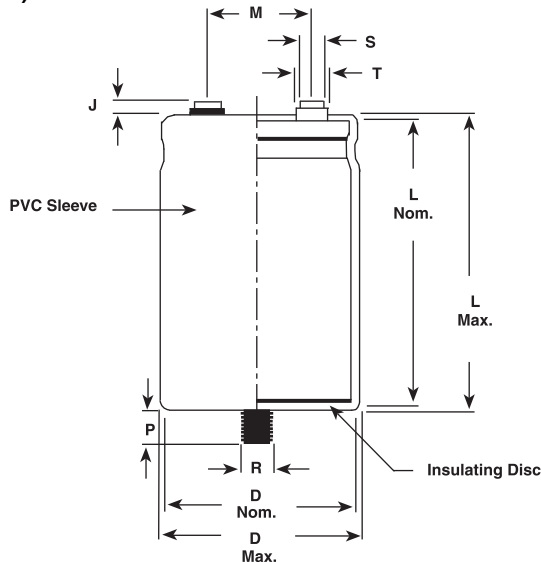
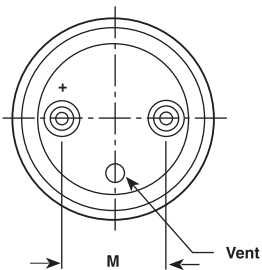

Note

• Not available on "DJ" case code, E diameters and "P" terminal option

DIMENSIONS in inches (millimeters)						
STUD						
CASE DIAMETER		R THREAD		HEIGHT P ± 0.039 (1.0)		
A		M8		0.472 (12.0)		
B, C, D		M12		0.630 (16.0)		
E		N/A		N/A		
TERMINAL CODE	THREAD	THREAD DEPTH	HEIGHT J ± 0.032 (0.8)	DIAMETER S ± 0.010 (0.25)	DIAMETER T ± 0.010 (0.25)	NOTES
A	10-32 NF-28	0.219 (5.6)	0.063 (1.6)	0.313 (8.0)	0.438 (11.1)	All sizes
B	10-32 NF-28	0.375 (9.5)	0.250 (6.4)	0.313 (8.0)	0.438 (11.1)	All sizes
D	1/4-28 NF-28	0.344 (8.7)	0.093 (2.4)	0.688 (17.5)	-	C and D dia. codes only
I	M5	0.375 (9.5)	0.250 (6.4)	0.313 (8.0)	-	Type 602D, 622D only
N	M5	0.219 (5.6)	0.063 (1.6)	0.313 (8.0)	0.438 (11.1)	Type 36D only
T	M5	0.375(9.5)	0.250 (6.4)	0.313 (8.0)	0.438 (11.1)	Type 36D only



Aluminum Capacitors
+ 85 °C and + 95 °C, Large Can

Vishay Sprague

Large Can Circuit Board Layout
(Bottom View)

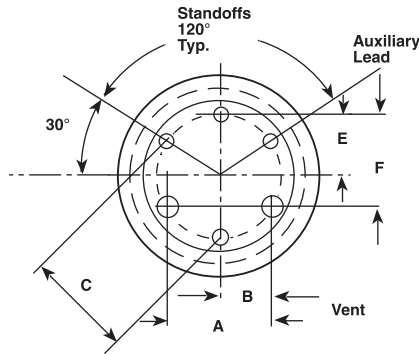
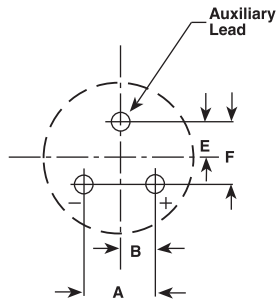

Circuit Board Mount "P" Terminal Dimensions

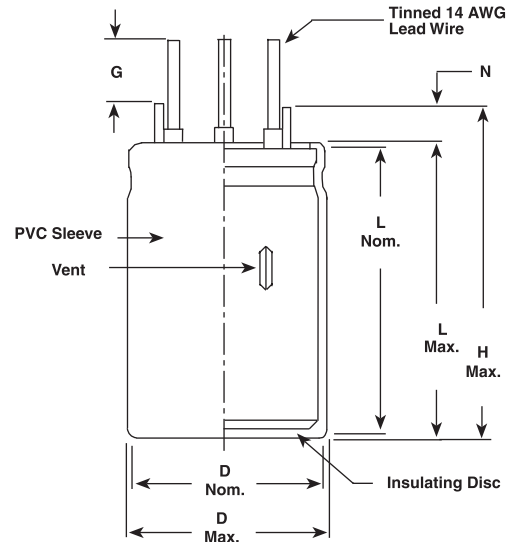

DIMENSIONS in inches (millimeters)						
BOARD						
NOMINAL CASE DIAMETER	A ± 0.032 (0.8)	B ± 0.032 (0.8)	C ± 0.032 (0.8)	E ± 0.032 (0.8)	F ± 0.032 (0.8)	G ± 0.020 (0.5)
1.375 (35.0)	0.500 (12.7)	0.250 (6.4)	0.937 (23.8)	0.375 (9.5)	0.550 (14.0)	0.312 (7.9)
1.750 (44.0)	0.700 (17.8)	0.350 (8.9)	1.350 (31.8)	0.525 (13.3)	0.900 (22.9)	0.312 (7.9)
2.000 (51.0)	0.800 (20.3)	0.400 (10.2)	1.400 (38.10)	0.575 (14.6)	1.000 (25.4)	0.312 (7.9)

Large Can Mounting Kits (Insulated)

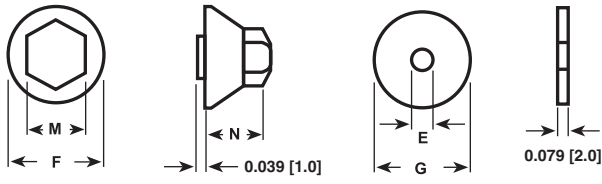
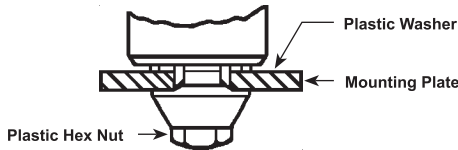

Large Can Mounting Kits (Uninsulated)

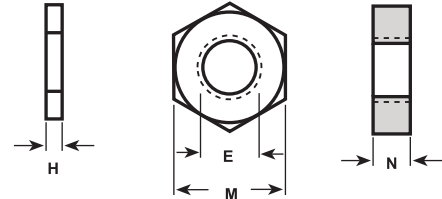
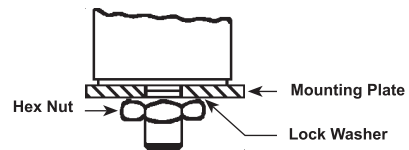

DIMENSIONS in inches (millimeters)						
MOUNTING KITS						
TYPE	PART NUMBER	E	F	G	H	M
Insulated M8	50-8	0.331 (8.4)	1.0 (25.0)	1.0 (25.0)	-	0.669 (17.0)
Uninsulated M8	50-8A	0.331 (8.4)	-	0.551 (14.0)	0.31 (0.8)	0.512 (13.0)
Insulated M12	50-8B	0.512 (13.0)	1.181 (30.0)	1.0 (25.0)	-	0.748 (19.0)
Uninsulated M12	50-8C	0.512 (13.0)	-	0.807 (20.5)	0.38 (1.0)	0.748 (19.0)

36DA

Vishay Sprague

Aluminum Capacitors
+ 85 °C and + 95 °C, Large Can



Large Can Brackets

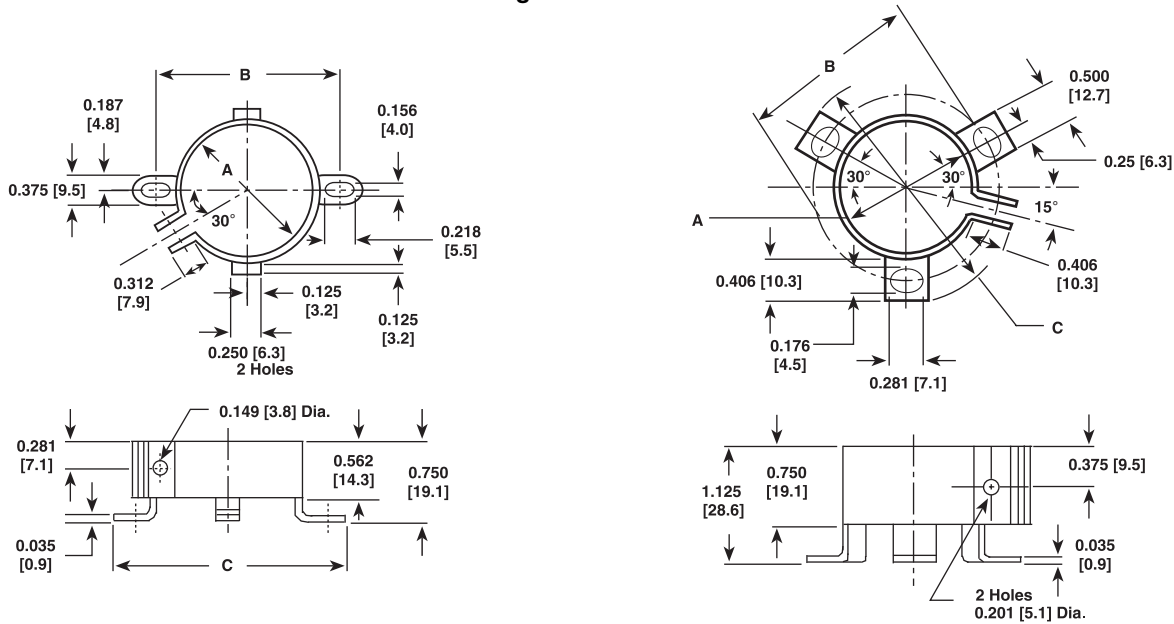

DIMENSIONS in inches (millimeters)					
BRACKETS (RoHS COMPLIANT)					
TYPE	PART NUMBER	A	B	C	FIGURE NUMBER
2 Feet	1245860035A	1.375 (35.0)	1.781 (45.0)	2.218 (56.3)	1
3 Feet	1245860036A	2.000 (51.0)	2.500 (64.0)	2.875 (73.0)	2
3 Feet	1245860037A	2.500 (64.0)	3.000 (76.0)	3.375 (85.7)	2
3 Feet	1245860038A	3.000 (76.0)	3.500 (88.9)	3.875 (98.4)	2

ORDERING EXAMPLE

Electrolytic capacitor 36DA series: 36DA 183 F 016 AN 2 A

DESCRIPTION	
CODE	EXPLANATION
36DA	Product type
183	Capacitance value (18 000 µF)
F	Tolerance (G = - 10 %/+ 75 %; F = - 10 %/+ 50 %)
016	Voltage rating at 85 °C (16 V)
AN	Can size (see dimensions table)
2	PVC insulating sleeve
A	Terminal code (low insert 10-32 screw thread)



Aluminum Capacitors
+ 85 °C and + 95 °C, Large Can

Vishay Sprague

ELECTRICAL DATA AND ORDERING INFORMATION				
CAPACITANCE (μF)	PART NUMBER	NOMINAL CASE SIZE D x L	MAX. ESR at 25 °C (mΩ) 120 Hz	MAX. RIPPLE at + 85 °C (A) 120 Hz
16 WVDC at + 85 °C, SURGE = 8 V				
18 000.0	36DA183F016AN2A	1.375 x 1.625 (35.0 x 41.0)	47.7	4.30
25 WVDC at + 85 °C, SURGE = 30 V				
8200.0	36DA822F025AN2A	1.375 x 1.625 (35.0 x 41.0)	51.5	4.10
12 000.0	36DA123F025AA2A	1.375 x 2.125 (35.0 x 54.0)	32.6	5.70
39 000.0	36DA393F025BM2A	2.000 x 2.625 (51.0 x 67.0)	13.7	12.2
50 WVDC at + 85 °C, SURGE = 65 V				
6800.0	36DA682F050AA2A	1.375 x 2.125 (35.0 x 54.0)	40.0	5.20
27 000.0	36DA273F050BB2A	2.000 x 3.125 (51.0 x 79.0)	13.3	13.20
47 000.0	36DA473F050CB2A	2.500 x 3.125 (64.0 x 79.0)	9.5	18.10
63 WVDC at + 85 °C, SURGE = 79 V				
2700.0	36DA272F063AN2A	1.375 x 1.625 (35.0 x 41.0)	69.0	3.62
160 WVDC at + 85 °C, SURGE = 200 V				
4700.0	36DA472F160BL2A	2.000 x 3.625 (51.0 x 92.0)	54.7	5.60
200 WVDC at + 85 °C, SURGE = 250 V				
1500.0	36DA152F200AB2A	1.375 x 3.125 (35.0 x 79.0)	84.0	3.43
2200.0	36DA222F200BM2A	2.000 x 2.675 (51.0 x 67.0)	72.0	4.36
8200.0	36DA822F200DL2A	3.000 x 3.625 (76.0 x 92.0)	20.0	12.04
250 WVDC at + 85 °C, SURGE = 300 V				
560.0	36DA561F250AA2A	1.375 x 2.125 (35.0 x 54.0)	158.0	2.15
350 WVDC at + 85 °C, SURGE = 400 V				
270.0	36DA271F350AA2A	1.375 x 2.125 (35.0 x 54.0)	590.6	1.12
470.0	36DA471F350AM2A	1.375 x 2.625 (35.0 x 41.0)	388.0	1.49
3300.0	36DA332F350CD2A	2.500 x 4.625 (64.0 x 117.0)	50.0	7.44
5600.0	36DA562F350DD2A	3.000 x 4.625 (76.0 x 117.0)	37.0	9.68
400 WVDC at + 85 °C, SURGE = 450 V				
1200.0	36DA122F400BL2A	2.000 x 3.625 (51.0 x 92.0)	150.0	3.41
450 WVDC at + 85 °C, SURGE = 525 V				
1200.0	36DA122F450BC2A	2.000 x 4.125 (51.0 x 105.0)	113.0	4.13
2200.0	36DA222F450CC2A	2.500 x 4.125 (64.0 x 105.0)	62.0	6.39



Disclaimer

All product specifications and data are subject to change without notice.

Vishay Intertechnology, Inc., its affiliates, agents, and employees, and all persons acting on its or their behalf (collectively, "Vishay"), disclaim any and all liability for any errors, inaccuracies or incompleteness contained herein or in any other disclosure relating to any product.

Vishay disclaims any and all liability arising out of the use or application of any product described herein or of any information provided herein to the maximum extent permitted by law. The product specifications do not expand or otherwise modify Vishay's terms and conditions of purchase, including but not limited to the warranty expressed therein, which apply to these products.

No license, express or implied, by estoppel or otherwise, to any intellectual property rights is granted by this document or by any conduct of Vishay.

The products shown herein are not designed for use in medical, life-saving, or life-sustaining applications unless otherwise expressly indicated. Customers using or selling Vishay products not expressly indicated for use in such applications do so entirely at their own risk and agree to fully indemnify Vishay for any damages arising or resulting from such use or sale. Please contact authorized Vishay personnel to obtain written terms and conditions regarding products designed for such applications.

Product names and markings noted herein may be trademarks of their respective owners.