



Ordering Information

Part Numbers	Description	Module Speed
SG564568FH8NWLC	256Mx64 (2GB), DDR3, 204-pin Unbuffered SO-DIMM, Non-ECC, 128Mx8 Based, DDR3-1066-7-7-7, 1.5V, 30.00mm, Green Module (RoHS Compliant).	PC3-8500 @ CL 7, 8
SG564568FH8NWPH	256Mx64 (2GB), DDR3, 204-pin Unbuffered SO-DIMM, Non-ECC, 128Mx8 Based, DDR3-1333-9-9-9, 1.5V, 30.00mm, Green Module (RoHS Compliant).	PC3-10600 @ CL 9
SG564568FJ8NWLC	256Mx64 (2GB), DDR3, 204-pin Unbuffered SO-DIMM, Non-ECC, 128Mx8 Based, DDR3-1066-7-7-7, 1.35V/1.5V, 30.00mm, Green Module (RoHS Compliant).	PC3L-8500 @ CL 7, 8
SG564568FJ8NWPH	256Mx64 (2GB), DDR3, 204-pin Unbuffered SO-DIMM, Non-ECC, 128Mx8 Based, DDR3-1333-9-9-9, 1.35V/1.5V, 30.00mm, Green Module (RoHS Compliant).	PC3L-10600 @ CL 9

(All specifications of this module are subject to change without notice.)



Revision History

- **June 1, 2010**
Corrected the Module Speed in the Ordering Information on page 1.
- **April 15, 2010**
Updated datasheet part number from SG564568FH8NWPH to SG564568FU8NWPH because of the addition of a new module operating voltage.
Added SG564568FJ8NWLC & SG564568FJ8NWPH to the Ordering Information on page 1.
Removed part numbers that are not recommended from the datasheet.
- **February 19, 2009**
Changed the Ordering Information on page 1 to highlight the recommended part numbers.
Updated datasheet to include a thermal sensor.
Updated SPD to Jedec revision 1.0.
- **July 16, 2008**
Datasheet released.

2GByte (256Mx64) DDR3 SDRAM Module - 128Mx8 Based 204-pin SO-DIMM, Unbuffered, Non-ECC

Features

- Standard = JEDEC
- Configuration = Non-ECC
- Number of Module Ranks = 2
- $V_{DD} = V_{DDQ} = 1.35V/1.5V$ or 1.5V
- $V_{DDSPD} = 1.7V$ to 3.6V
- Cycle Time = 1.875 (PC3-8500)
1.5ns (PC3-10600)
- \overline{CAS} Latency = 5, 6, 7, 8, 9
- Additive Latency = 0, CL-1, and CL-2
- CAS Write Latency (CWL) = 5, 6, 7
- Burst Length = BC4, BL8, BC4 or BL8 (on the fly)
- Burst Length = Nibble Sequential & Interleave Mode
- Internal Banks per SDRAM = 8
- Refresh = 8K/64ms
- Device Package = FBGA
- Lead Finish = Gold
- Length x Height = 133.35mm x 30.00mm
- No. of sides = Double-sided
- Mating Connector (Examples)
Horizontal = Foxconn - AS0A626-UASN-7F
- On chip DLL align DQ, DQS and \overline{DQS} transition with CK transition
- DM write data-in at the both rising and falling edges of the data strobe
- All addresses and control inputs latched on the rising edges of the clock
- Dynamic On Die Termination supported
- Driver strength selected by EMRS
- Asynchronous RESET pin supported
- Write Levelization supported
- 8-bit pre-fetch

Addressing

Device Configuration	128Mx8
Number of Internal Banks	8
Bank Address	BA0 - BA2
Auto precharge	A10/AP
BC switch on the fly	A12/ \overline{BC}
Row Address	A0 - A13
Column Address	A0 - A9

Pin Description Table

Symbol	Type	Polarity	Function
$\overline{CK0} \sim \overline{CK1}$, $\overline{CK0} \sim \overline{CK1}$	SSTL_15	Differential Crossing	CK and \overline{CK} are differential clock inputs. All the DDR3 SDRAM address/control inputs are sampled on the crossing of the positive edge of CK and the negative edge of \overline{CK} . Output (read) data is referenced to the crossing of CK and \overline{CK} (Both directions of crossing).
CKE0, CKE1	SSTL_15	Active High	Activates the SDRAM CK signal when high and deactivates the CK signal when low. By deactivating the clocks, CKE low initiates the Power Down mode, or the Self Refresh mode.
$\overline{CS0}$, $\overline{CS1}$	SSTL_15	Active Low	Enables the associated SDRAM command decoder when low and disables the command decoder when high. When decoder is disabled, new commands are ignored but previous operations continue. This signal provides for external rank selection on systems with multiple ranks.
ODT0, ODT1	SSTL_15	Active High	When high, termination resistance is enabled for all DQ, DQS, \overline{DQS} and DM pins, assuming this function is enabled on the DRAM.



Pin Description Table (Contd.)

Symbol	Type	Polarity	Function
BA0~BA2	SSTL_15	-	Selects which SDRAM bank of the eight is activated.
A0~A13	SSTL_15	-	During a Bank Activate command cycle, address inputs define the row address (RA0-RA13). During a Read or Write command cycle, address inputs define the column address (CA0-CA9). In addition to the column address, AP is used to invoke auto-precharge operation at the end of the burst read or write cycle. If AP is high, auto-precharge is selected and BA0, BA1, BA2 defines the bank to be precharged. If AP is low, auto-precharge is disabled. During a Precharge command cycle, AP is used in conjunction with BA0, BA1, BA2 to control which bank(s) to precharge. If AP is high, all banks will be precharged regardless of the state of BA0, BA1 or BA2. If AP is low, BA0, BA1 and BA2 are used to define which bank to precharge. A12(BC) is sampled during READ and WRITE commands to determine if burst chop (on-the-fly) will be performed (HIGH, no burst chop; LOW, burst chopped).
RAS, CAS, WE	SSTL_15	Active Low	RAS, CAS, and WE (along with CS) define the command being entered.
DQ0~DQ63	SSTL_15	-	Data Input/Output pins.
DQS0~DQS7 DQS0~DQS7	SSTL_15	Differential Crossing	Data strobe for input and output data.
DM0~DM7	SSTL_15	Active High	DM is an input mask signal for write data. Input data is masked when DM is sampled high coincident with that input data during a write access. DM is sampled on both edges of DQS. Although DM pins are input only, the DM loading matches the DQ and DQS loading.
SA0~SA1		-	These signals are tied at the system to either V _{SS} or V _{DDSPD} to configure the serial SPD EEPROM address range.
SDA		-	This bidirectional pin is used to transfer data into or out of the SPD EEPROM. An external resistor may be connected from the SDA bus line to V _{DDSPD} to act as a pullup on the system board.
SCL		-	This signal is used to clock data into and out of the SPD EEPROM. An external resistor may be connected from the SCL bus tied to V _{DDSPD} to act as a pullup on the system board.
EVENT	Output	Active Low	This signal indicates that a thermal event has been detected in the thermal sensing device. The system should guarantee the electrical level requirement is met for the EVENT pin on TS/SPD part. No pull-up resistor is provided on DIMM.
RESET	CMOS	Active Low	Asynchronous Reset is active when RESET is LOW, and inactive when RESET is HIGH. RESET must be HIGH during normal operation. RESET is CMOS rail to rail signal with DC high and low at 80% and 20% of V _{DD} .
V _{DD} , V _{SS}	Supply	-	Power and ground for the DDR3 SDRAM input buffers, and core logic. V _{DD} and V _{DDQ} pins are tied to V _{DD} /V _{DDQ} planes on these modules.
V _{DDQ}	Supply	-	Power supply for the DDR3 SDRAM output buffers to provide improved noise immunity. V _{DDQ} shares the same power plane as V _{DD} pins.
V _{REFDQ}	Supply		Reference voltage for I/O inputs.
V _{REFCA}	Supply	-	Reference voltage for address/command inputs.
V _{DDSPD}	Supply	-	Power supply for SPD EEPROM. This supply is separate from the V _{DD} /V _{DDQ} power plane.
V _{TT}	Supply	-	Termination voltage for address/command/control/clock nets.
NC	-	-	No Connect.



DDR3 204-pin SO-DIMM Pin List

Pin No	Pin Name	Pin No	Pin Name	Pin No	Pin Name	Pin No	Pin Name	Pin No	Pin Name	Pin No	Pin Name	Pin No	Pin Name	Pin No	Pin Name
1	V _{REFDQ}	2	V _{SS}	53	DQ19	54	V _{SS}	105	V _{DD}	106	V _{DD}	157	DQ42	158	DQ46
3	V _{SS}	4	DQ4	55	V _{SS}	56	DQ28	107	A10/AP	108	BA1	159	DQ43	160	DQ47
5	DQ0	6	DQ5	57	DQ24	58	DQ29	109	BA0	110	$\overline{\text{RAS}}$	161	V _{SS}	162	V _{SS}
7	DQ1	8	V _{SS}	59	DQ25	60	V _{SS}	111	V _{DD}	112	V _{DD}	163	DQ48	164	DQ52
9	V _{SS}	10	$\overline{\text{DQS0}}$	61	V _{SS}	62	$\overline{\text{DQS3}}$	113	$\overline{\text{WE}}$	114	$\overline{\text{CS0}}$	165	DQ49	166	DQ53
11	DM0	12	DQS0	63	DM3	64	DQS3	115	$\overline{\text{CAS}}$	116	ODT0	167	V _{SS}	168	V _{SS}
13	V _{SS}	14	V _{SS}	65	V _{SS}	66	V _{SS}	117	V _{DD}	118	V _{DD}	169	$\overline{\text{DQS6}}$	170	DM6
15	DQ2	16	DQ6	67	DQ26	68	DQ30	119	A13	120	ODT1	171	DQS6	172	V _{SS}
17	DQ3	18	DQ7	69	DQ27	70	DQ31	121	$\overline{\text{CS1}}$	122	NC	173	V _{SS}	174	DQ54
19	V _{SS}	20	V _{SS}	71	V _{SS}	72	V _{SS}	123	V _{DD}	124	V _{DD}	175	DQ50	176	DQ55
21	DQ8	22	DQ12	73	CKE0	74	CKE1	125	NC	126	V _{REFCA}	177	DQ51	178	V _{SS}
23	DQ9	24	DQ13	75	V _{DD}	76	V _{DD}	127	V _{SS}	128	V _{SS}	179	V _{SS}	180	DQ60
25	V _{SS}	26	V _{SS}	77	NC	78	A15 (NC)	129	DQ32	130	DQ36	181	DQ56	182	DQ61
27	$\overline{\text{DQS1}}$	28	DM1	79	BA2	80	A14 (NC)	131	DQ33	132	DQ37	183	DQ57	184	V _{SS}
29	DQS1	30	$\overline{\text{RESET}}$	81	V _{DD}	82	V _{DD}	133	V _{SS}	134	V _{SS}	185	V _{SS}	186	$\overline{\text{DQS7}}$
31	V _{SS}	32	V _{SS}	83	A12/ $\overline{\text{BC}}$	84	A11	135	$\overline{\text{DQS4}}$	136	DM4	187	DM7	188	DQS7
33	DQ10	34	DQ14	85	A9	86	A7	137	DQS4	138	V _{SS}	189	V _{SS}	190	V _{SS}
35	DQ11	36	DQ15	87	V _{DD}	88	V _{DD}	139	V _{SS}	140	DQ38	191	DQ58	192	DQ62
37	V _{SS}	38	V _{SS}	89	A8	90	A6	141	DQ34	142	DQ39	193	DQ59	194	DQ63
39	DQ16	40	DQ20	91	A5	92	A4	143	DQ35	144	V _{SS}	195	V _{SS}	196	V _{SS}
41	DQ17	42	DQ21	93	V _{DD}	94	V _{DD}	145	V _{SS}	146	DQ44	197	SA0	198	$\overline{\text{EVENT}}$
43	V _{SS}	44	V _{SS}	95	A3	96	A2	147	DQ40	148	DQ45	199	V _{DDSPD}	200	SDA
45	$\overline{\text{DQS2}}$	46	DM2	97	A1	98	A0	149	DQ41	150	V _{SS}	201	SA1	202	SCL
47	DQS2	48	V _{SS}	99	V _{DD}	100	V _{DD}	151	V _{SS}	152	$\overline{\text{DQS5}}$	203	V _{TT}	204	V _{TT}
49	V _{SS}	50	DQ22	101	CK0	102	CK1	153	DM5	154	DQS5				
51	DQ18	52	DQ23	103	$\overline{\text{CK0}}$	104	$\overline{\text{CK1}}$	155	V _{SS}	156	V _{SS}				



Block Diagram

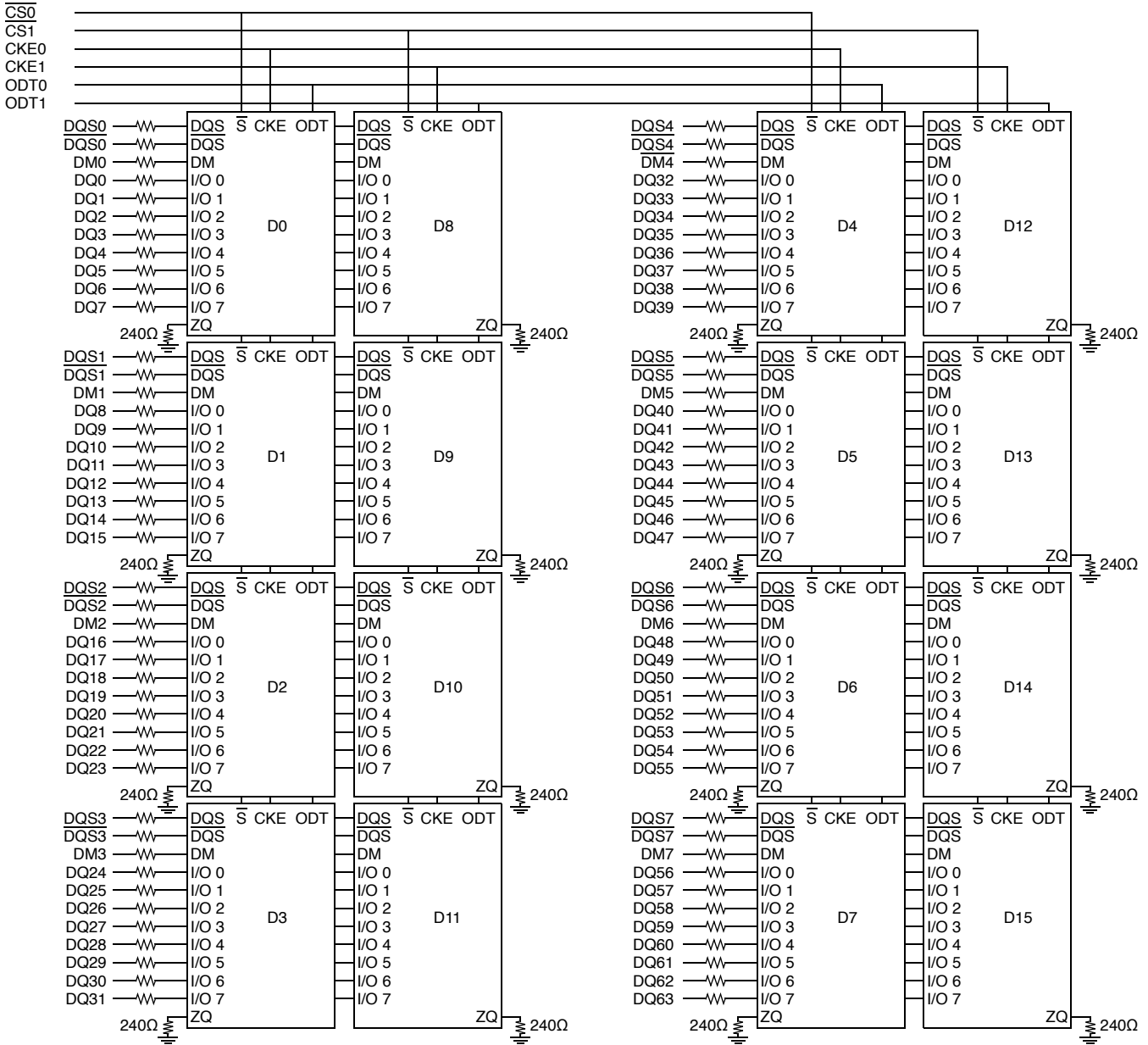

Note: Unless otherwise noted, data resistor values are $15\Omega \pm 5\%$.

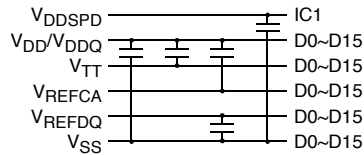
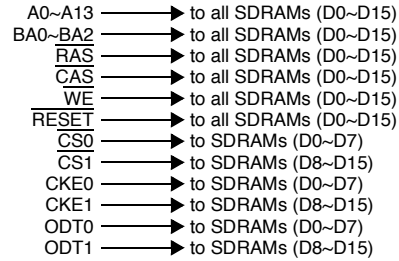
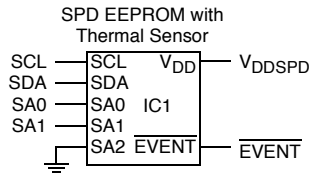
Block Diagram (Contd.)

Clock Wiring	
CK0/CK0	8 SDRAMs
CK1/CK1	8 SDRAMs

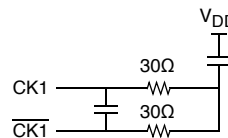
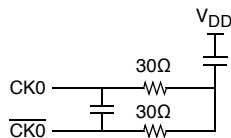
Notes:

1. All address, command and control signal lines are terminated through a 36Ω series resistor to V_{TT} .
2. Data bits may be swapped within a device. However, DQ/DQS/DM relationship must be maintained as shown on page 6.

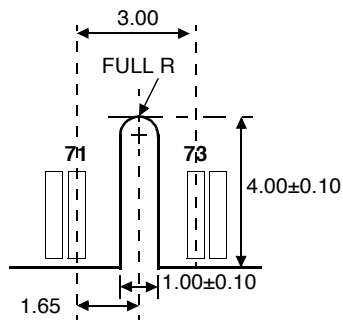
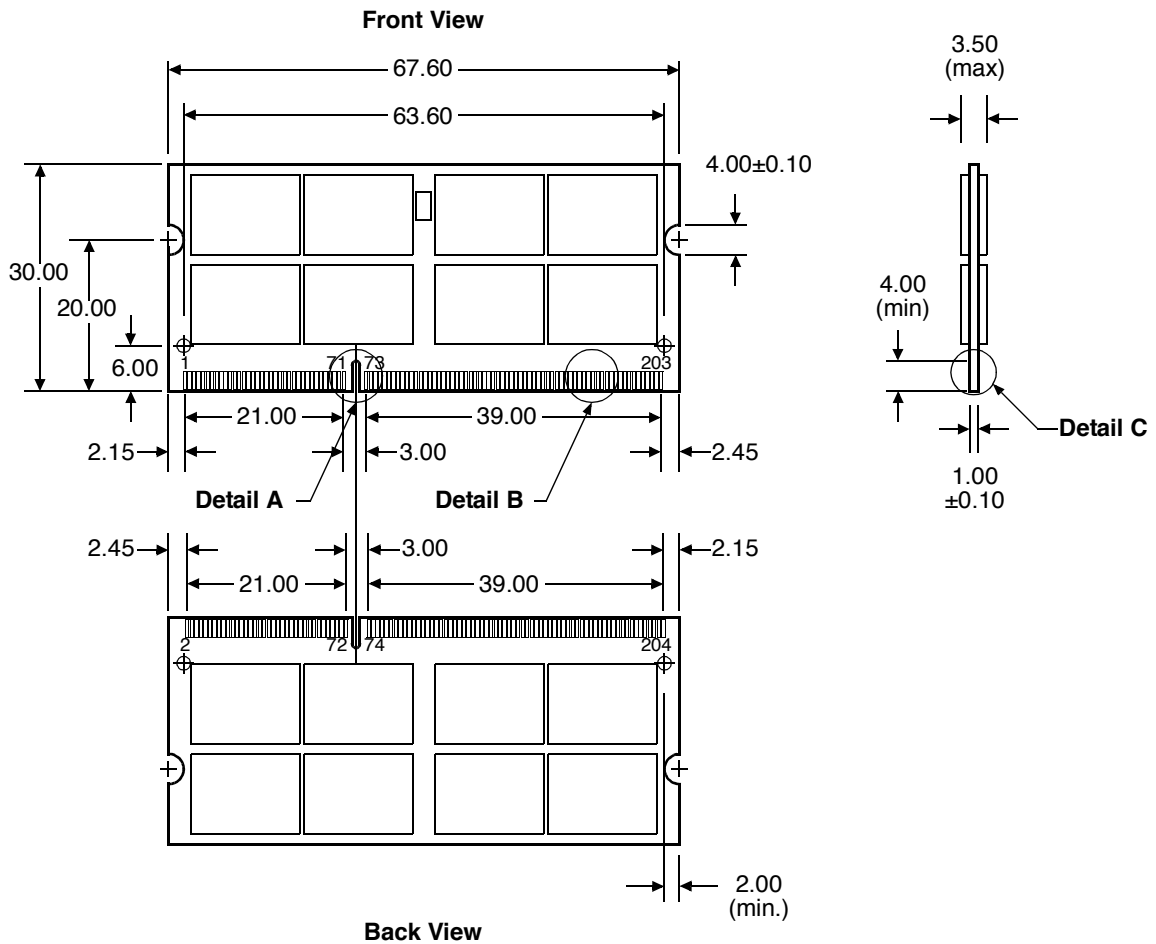
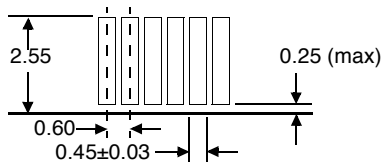
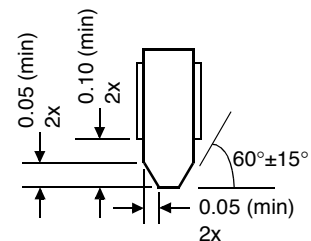
Physical Dimensions
204-pin SO-DIMM Module

Detail A: Position of Voltage Notch

Detail B: Edge Connector

Detail C

(All dimensions are in millimeters with ±0.15mm tolerance unless specified otherwise.)

1.35V Serial Presence Detect Table

Byte No.	Byte Description	Speed	Value Supported	Hex Value
0	No. of Bytes Used, No. of Bytes in SPD Device, CRC Coverage	All	176, 256, 0~116	92h
1	SPD Revision	All	Revision 1.0	10h
2	Key Byte/DRAM Device Type	All	DDR3 SDRAM	0Bh
3	Key Byte/Module Type	All	SO-DIMM	03h
4	SDRAM Density and Banks	All	1Gb, 8 Banks	02h
5	SDRAM Addressing	All	14 Rows, 10 Columns	11h
6	Module Nominal Voltage, V_{DD}	All	1.35V and 1.5V	02h
7	Module Organization	All	2 Ranks, x8	09h
8	Module Memory Bus Width	All	x64	03h
9	Fine Timebase (FTB) Dividend/Divisor	All	2.5ps	52h
10	Medium Timebase Dividend	All	1	01h
11	Medium Timebase Divisor	All	8	08h
12	Minimum SDRAM Cycle Time (t_{CKmin})	-LC -PH	1.875ns 1.5ns	0Fh 0Ch
13	Reserved	All	-	00h
14	CAS Latencies Supported (CL4-CL11)	-LC -PH	5, 6, 7, 8 5, 6, 7, 8, 9	1Eh 3Eh
15	CAS Latencies Supported (CL12-CL18)	All	-	00h
16	Minimum CAS Latency Time (t_{AAmin})	All	13.125ns	69h
17	Minimum Write Recovery Time (t_{WRmin})	All	15ns	78h
18	Minimum RAS to CAS Delay Time (t_{RCDmin})	All	13.125ns	69h
19	Minimum Row Active to Row Active Delay Time (t_{RRDmin})	-LC -PH	7.5ns 6ns	3Ch 30h
20	Minimum Row Precharge Delay Time (t_{RPmin})	All	13.125ns	69h
21	Upper Nibbles for t_{RAS} and t_{RC}	All	-	11h
22	Minimum Active to Precharge Delay Time (t_{RASmin})	-LC -PH	37.5ns 36ns	2Ch 20h
23	Minimum Active to Active/Refresh Delay Time (t_{RCmin})	-LC -PH	50.625ns 49.125ns	95h 89h



1.35V Serial Presence Detect Table (Contd.)

Byte No.	Byte Description	Speed	Value Supported	Hex Value
24	Minimum Refresh Recovery Delay Time ($t_{RFC-min}$) (LSB)	All	110ns	70h
25	Minimum Refresh Recovery Delay Time ($t_{RFC-min}$) (MSB)	All	110ns	03h
26	Minimum Internal Write to Read Command Delay Time (t_{WTRmin})	All	7.5ns	3Ch
27	Minimum Internal Read to Precharge Command Delay Time (t_{RTPmin})	All	7.5ns	3Ch
28	Upper Nibble for t_{FAW}	-LC -PH	37.5ns 30ns	01h 00h
29	Minimum Four Active Window Delay Time (t_{FAW})	-LC -PH	37.5ns 30ns	2Ch F0h
30	SDRAM Output Drivers Supported	All	DLL-off Mode, RZQ/7, RZQ/6	83h
31	SDRAM Thermal and Refresh Options	All	ASR, Ext. Temp. Range	05h
32	Module Thermal Sensor	All	EEPROM with Thermal Sensor	80h
33	SDRAM Device Type	All	Monolithic	00h
34~59	Reserved	All	-	00h
60	Module Nominal Height	All	30mm	0Fh
61	Module Maximum Thickness	All	1 mm < x ≤ 2 mm Front 1 mm < x ≤ 2 mm Back	11h
62	Reference Raw Card Used	All	R/C F, Rev. 1	25h
63	Address Mapping from Edge Connector to DRAM	All	Standard	00h
64~116	Reserved	All	-	00h
117	Module Manufacturer ID Code (LSB)	All	Continuation Code	01h
118	Module Manufacturer ID Code (MSB)	All	Smart ID code	94h
119	Module Manufacturing Location	All	See Note 1	01h
120	Module Manufacturing Date (Year)	All	Date	Date
121	Module Manufacturing Date (Week)	All	Date	Date
122~125	Module Serial Number	All	Serial Number	00h

1.35V Serial Presence Detect Table (Contd.)

Byte No.	Byte Description	Speed	Value Supported	Hex Value
126	SPD Cyclical Redundancy Code	-LC -PH		A4h E6h
127	SPD Cyclical Redundancy Code	-LC -PH		36h 9Fh
128~145	Module Part Number	-LC -PH	SG564568FJ8NWLC SG564568FJ8NWPH	
146	Module Revision Code (SPD Revision)	All	Revision 0	00h
147	Module Revision Code	All	-	00h
148	DRAM Manufacturer ID Code (LSB)	All	Generic	00h
149	DRAM Manufacturer ID Code (MSB)	All	Generic	00h
150~173	Manufacturer Specific Data	All	SMART Modular Technologies	
174~175	Manufacturer Specific Data	All	-	00h
176~255	Open for Customer use	All	-	00h

Note:

- Manufacturing Location:
 - 00h - Undefined,
 - 01h - Fremont, USA,
 - 02h - Aguada, Puerto Rico,
 - 03h - East Kilbride, Scotland,
 - 04h - Penang, Malaysia,
 - 05h - Bangalore, India,
 - 06h - Sao Paulo, Brazil,
 - 07h - Aguadilla, Puerto Rico,
 - 08h - Mayaguez, Puerto Rico,
 - 09h - Santo Domingo, Dominican Republic,
 - 0Ah - Dongguan, China,

1.5V Serial Presence Detect Table

Byte No.	Byte Description	Speed	Value Supported	Hex Value
0	No. of Bytes Used, No. of Bytes in SPD Device, CRC Coverage	All	176, 256, 0~116	92h
1	SPD Revision	All	Revision 1.0	10h
2	Key Byte/DRAM Device Type	All	DDR3 SDRAM	0Bh
3	Key Byte/Module Type	All	SO-DIMM	03h
4	SDRAM Density and Banks	All	1Gb, 8 Banks	02h
5	SDRAM Addressing	All	14 Rows, 10 Columns	11h
6	Module Nominal Voltage, V_{DD}	All	1.5V	00h
7	Module Organization	All	2 Ranks, x8	09h
8	Module Memory Bus Width	All	x64	03h
9	Fine Timebase (FTB) Dividend/Divisor	All	2.5ps	52h
10	Medium Timebase Dividend	All	1	01h
11	Medium Timebase Divisor	All	8	08h
12	Minimum SDRAM Cycle Time (t_{CKmin})	-LC -PH	1.875ns 1.5ns	0Fh 0Ch
13	Reserved	All	-	00h
14	CAS Latencies Supported (CL4-CL11)	-LC -PH	5, 6, 7, 8 5, 6, 7, 8, 9	1Eh 3Eh
15	CAS Latencies Supported (CL12-CL18)	All	-	00h
16	Minimum CAS Latency Time (t_{AAmin})	All	13.125ns	69h
17	Minimum Write Recovery Time (t_{WRmin})	All	15ns	78h
18	Minimum RAS to CAS Delay Time (t_{RCDmin})	All	13.125ns	69h
19	Minimum Row Active to Row Active Delay Time (t_{RRDmin})	-LC -PH	7.5ns 6ns	3Ch 30h
20	Minimum Row Precharge Delay Time (t_{RPmin})	All	13.125ns	69h
21	Upper Nibbles for t_{RAS} and t_{RC}	All	-	11h
22	Minimum Active to Precharge Delay Time (t_{RASmin})	-LC -PH	37.5ns 36ns	2Ch 20h
23	Minimum Active to Active/Refresh Delay Time (t_{RCmin})	-LC -PH	50.625ns 49.125ns	95h 89h



Serial Presence Detect Table (Contd.)

Byte No.	Byte Description	Speed	Value Supported	Hex Value
24	Minimum Refresh Recovery Delay Time ($t_{RFC-min}$) (LSB)	All	110ns	70h
25	Minimum Refresh Recovery Delay Time ($t_{RFC-min}$) (MSB)	All	110ns	03h
26	Minimum Internal Write to Read Command Delay Time (t_{WTRmin})	All	7.5ns	3Ch
27	Minimum Internal Read to Precharge Command Delay Time (t_{RTPmin})	All	7.5ns	3Ch
28	Upper Nibble for t_{FAW}	-LC -PH	37.5ns 30ns	01h 00h
29	Minimum Four Active Window Delay Time (t_{FAW})	-LC -PH	37.5ns 30ns	2Ch F0h
30	SDRAM Output Drivers Supported	All	DLL-off Mode, RZQ/7, RZQ/6	83h
31	SDRAM Thermal and Refresh Options	All	ASR, Ext. Temp. Range	05h
32	Module Thermal Sensor	All	EEPROM with Thermal Sensor	80h
33	SDRAM Device Type	All	Monolithic	00h
34~59	Reserved	All	-	00h
60	Module Nominal Height	All	30mm	0Fh
61	Module Maximum Thickness	All	Front = 1.2mm Back = 1.2mm	11h
62	Reference Raw Card Used	All	R/C F, Rev. 1	25h
63	Address Mapping from Edge Connector to DRAM	All	Standard	00h
64~116	Reserved	All	-	00h
117	Module Manufacturer ID Code (LSB)	All	Continuation Code	01h
118	Module Manufacturer ID Code (MSB)	All	Smart ID code	94h
119	Module Manufacturing Location	All	See Note 1	01h
120	Module Manufacturing Date (Year)	All	Date	Date
121	Module Manufacturing Date (Week)	All	Date	Date
122~125	Module Serial Number	All	Serial Number	00h

Serial Presence Detect Table (Contd.)

Byte No.	Byte Description	Speed	Value Supported	Hex Value
126	SPD Cyclical Redundancy Code	-LC -PH		0Fh 4Dh
127	SPD Cyclical Redundancy Code	-LC -PH		B1h 18h
128~145	Module Part Number	-LC -PH	SG564568FH8NWLC SG564568FH8NWPH	
146	Module Revision Code (SPD Revision)	-LC -PH	Revision 2 Revision 1	02h 01h
147	Module Revision Code	All	-	00h
148	DRAM Manufacturer ID Code (LSB)	All	Generic	00h
149	DRAM Manufacturer ID Code (MSB)	All	Generic	00h
150~173	Manufacturer Specific Data	All	SMART Modular Technologies	
174~175	Manufacturer Specific Data	All	-	00h
176~255	Open for Customer use	All	-	00h

Note:

- Manufacturing Location:
 - 00h - Undefined,
 - 01h - Fremont, USA,
 - 02h - Aguada, Puerto Rico,
 - 03h - East Kilbride, Scotland,
 - 04h - Penang, Malaysia,
 - 05h - Bangalore, India,
 - 06h - Sao Paulo, Brazil,
 - 07h - Aguadilla, Puerto Rico,
 - 08h - Mayaguez, Puerto Rico,
 - 09h - Santo Domingo, Dominican Republic,
 - 0Ah - Dongguan, China,

Mode Register (MR0) Table Definition

The mode register stores the data for controlling the various operating modes of DDR3 SDRAM. It controls CAS latency, burst length, burst chop, burst sequence, test mode, DLL reset, t_{WR} and various vendor specific options to make DDR3 SDRAM useful for various applications. The mode register is written by asserting low on \overline{CS} , \overline{RAS} , \overline{CAS} , \overline{WE} , BA0, BA1 and BA2 while controlling the state of address pins A0~A15.

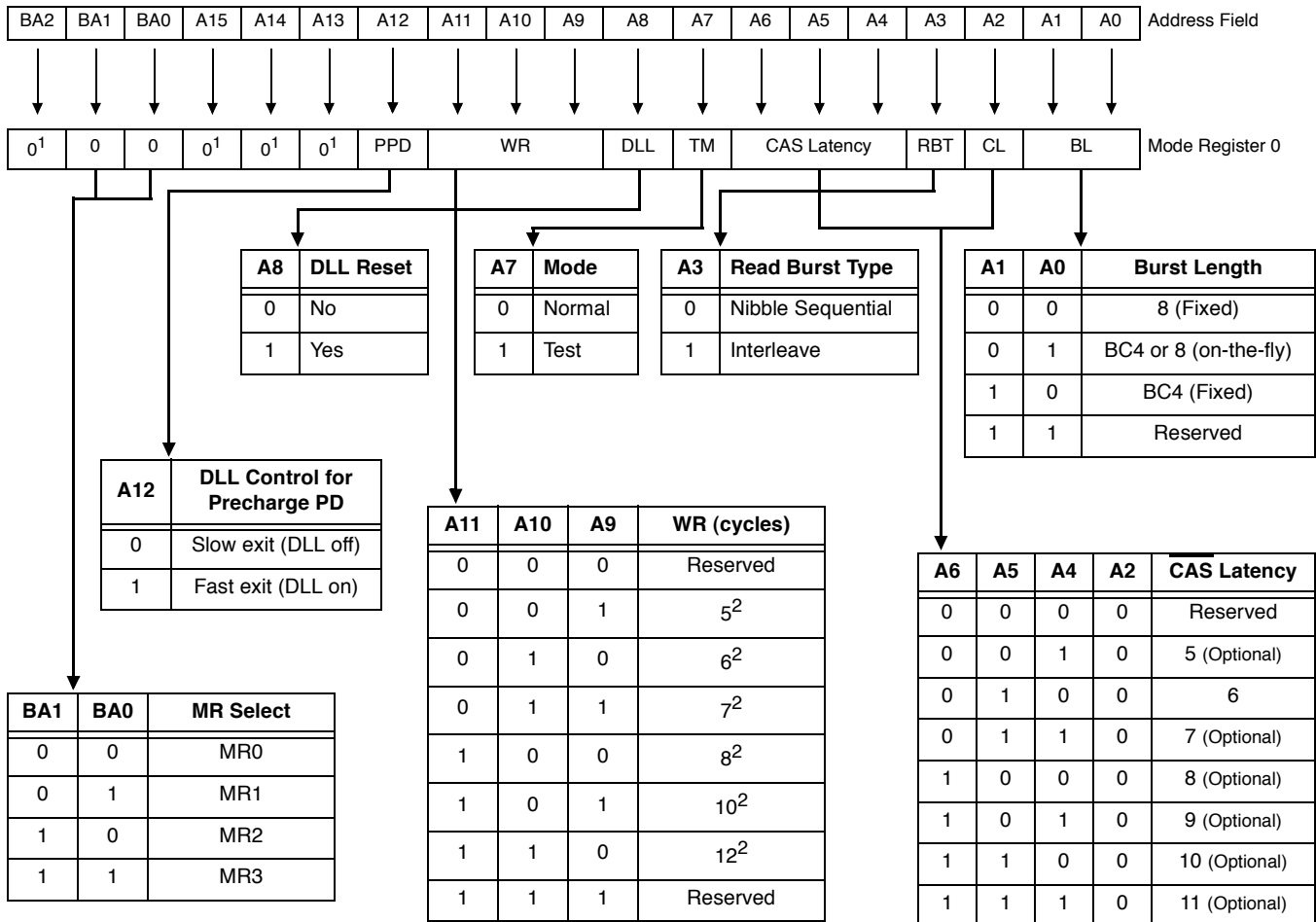

Notes:

- BA2 and A13~A15 are reserved for future use and must be programmed to 0 during MRS.
- WR (write recovery for auto-precharge) min in clock cycles is calculated by dividing t_{WR} (in ns) by t_{CK} (in ns) and rounding up to the next integer: $WR_{min} [\text{cycles}] = \text{Round-up} (t_{WR}[\text{ns}] / t_{CK}[\text{ns}])$. The WR value in the mode register must be programmed to be equal or larger than WR_{min} . The programmed WR value is used with t_{RP} to determine t_{DAL} .

Mode Register (MR1) Table Definition

The Mode Registers MR1 stores the data for enabling or disabling the DLL, output driver strength, RTT_Nom impedance, additive latency, Write Leveling enable, TDQS enable and Qoff. The Mode Register 1 is written by asserting low on \overline{CS} , \overline{RAS} , \overline{CAS} , \overline{WE} , high on BA0 and low on BA1 and BA2, while controlling the state of address pins A0~A15.

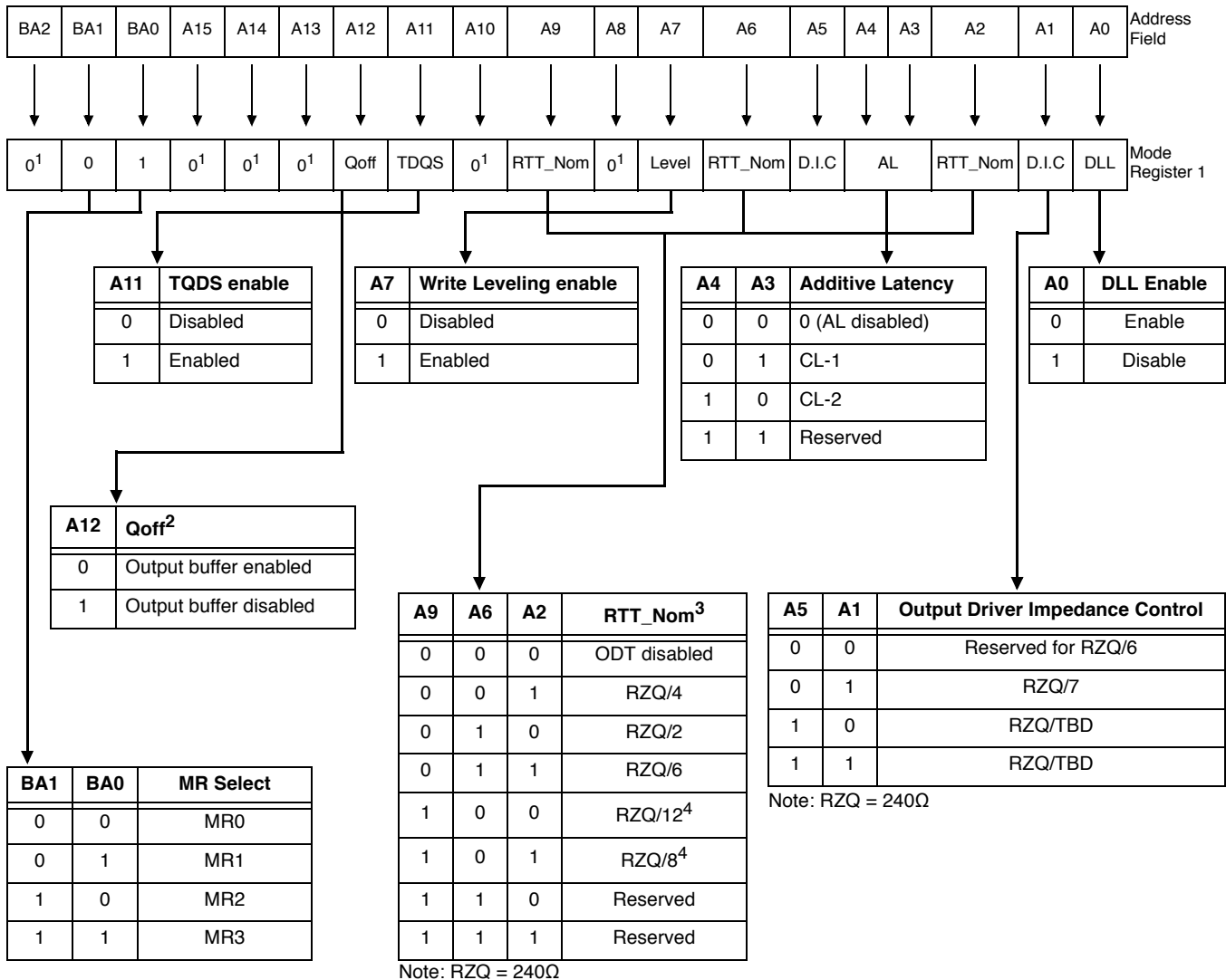

Notes:

1. BA2 and A8, A10, A13~A15 are reserved for future use and must be programmed to 0 during MRS.
2. Outputs disabled - DQs, DQSs, DQSs.
3. In Write Leveling Mode (MR1[bit7] = 1) with MR1[bit12] = 1, all RTT_Nom settings are allowed; in Write Leveling Mode (MR1[bit7] = 1) with MR1[bit12] = 0, only RTT_Nom settings of RZQ/2, RZQ/4 and RZQ/6 are allowed.
4. If RTT_Nom is used during Writes, only the values RZQ/2, RZQ/4 and RZQ/6 are allowed.



Mode Register (MR2) Table Definition

The Mode Registers MR2 stores the data for controlling refresh related features, RTT_Wr impedance, and CAS Write Latency. The Mode Register 2 is written by asserting low on \overline{CS} , \overline{RAS} , \overline{CAS} , \overline{WE} , high on BA1 and low on BA0 and BA2 while controlling the state of address pins A0~A15.

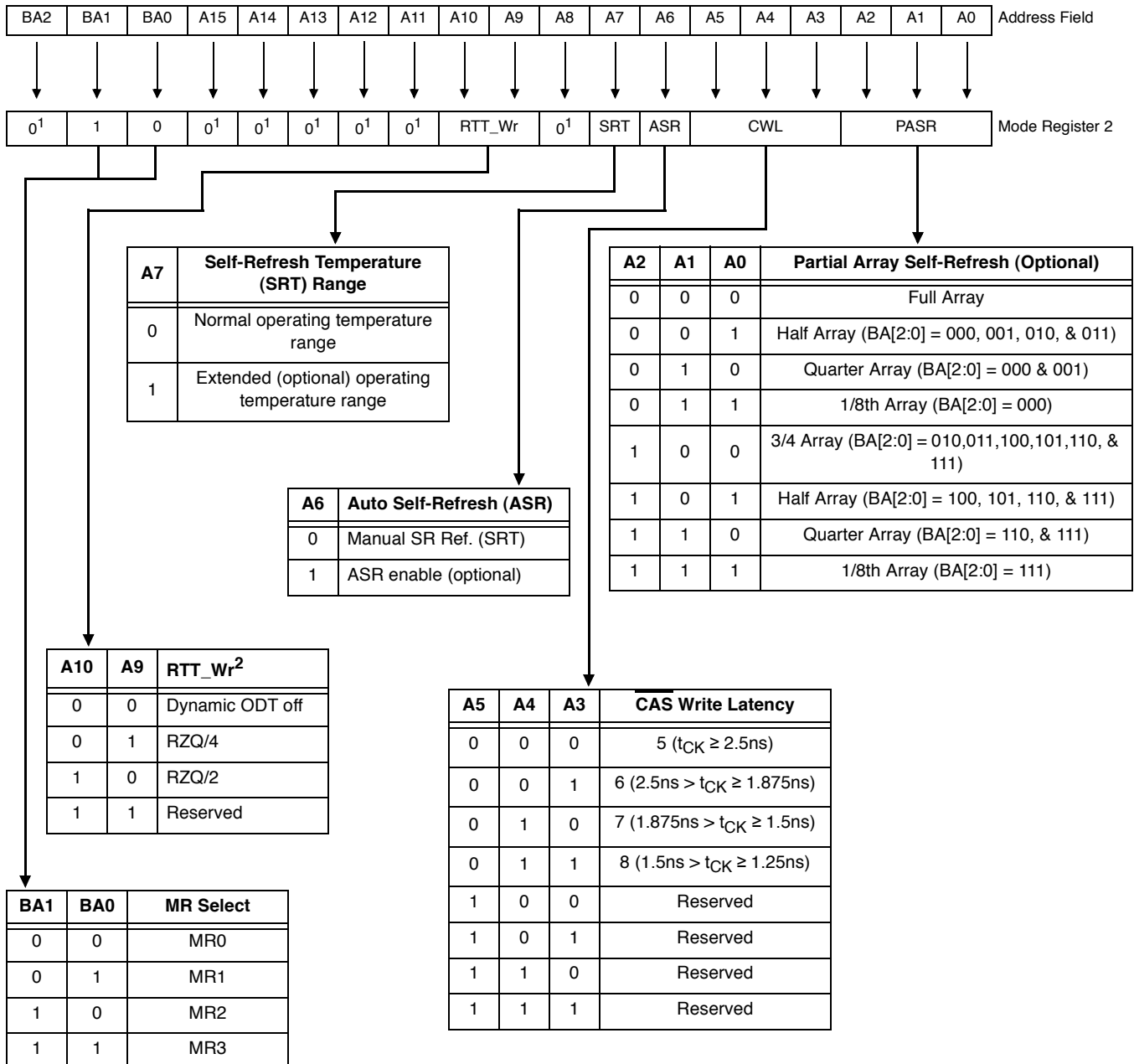

Notes:

- BA2, A8 and A11~A15 are reserved for future use and must be programmed to 0 during MRS.
- If RTT_Wr value can be applied during writes even when RTT_Nom is disabled. During Write Leveling, Dynamic ODT is not available.

Mode Register (MR3) Table Definition

The Mode Register MR3 controls Multi-purpose registers. The Mode Register 3 is written by asserting low on \overline{CS} , \overline{RAS} , \overline{CAS} , \overline{WE} , high on BA1 and BA0, low on BA2 while controlling the state of address pins A0~A15.

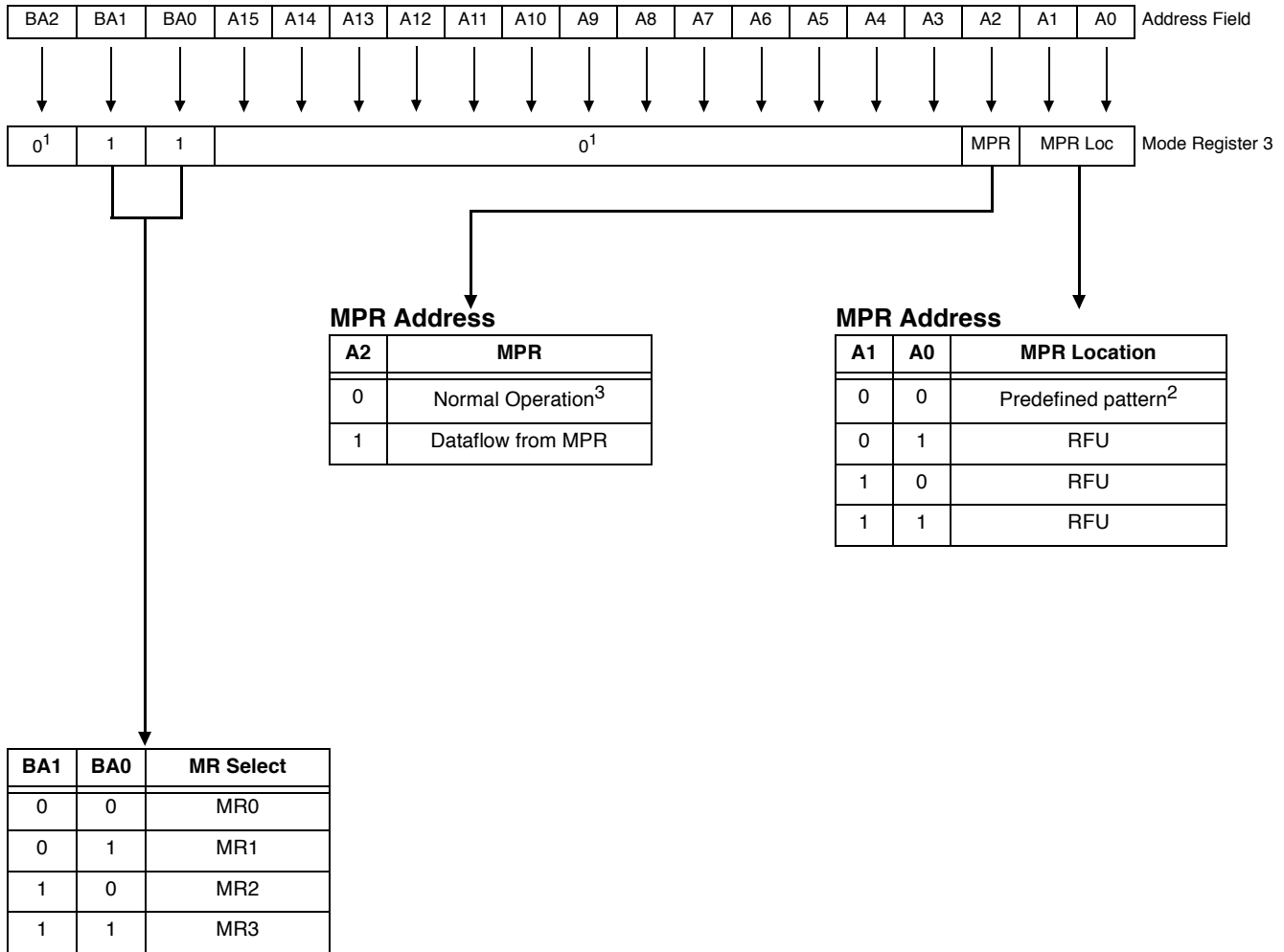

Notes:

1. BA2, A3~A15 are reserved for future use and must be programmed to 0 during MRS.
2. The predefined pattern will be used for read synchronization.
3. When MPR control is set for normal operation (MR3 A[2] = 0), then MR3 A[1:0] will be ignored.

Command Truth Table

The following Truth Tables provide a general reference of available commands. For a more detailed description please refer to the device data sheets.

(a) Notes 1- 4 apply to the entire Command Truth Table.

(b) Note 5 applies to all Read/Write command.

[BA= Bank address, RA= row Address, CA = Column Address, \overline{BC} = Burst chop, X = Don't care, V = Valid]

Function	Abbreviation	CKE		CS	RAS	CAS	WE	BA0~BA2	A13~A15	A12/ \overline{BC}	A10/AP	A0-A9, A11	Notes
		Previous Cycle	Current Cycle										
Mode Register Set	MRS	H	H	L	L	L	L	BA	OP Code				
Refresh	REF	H	H	L	L	L	H	V	V	V	V	V	
Self-Refresh Entry	SRE	H	L	L	L	L	H	V	V	V	V	V	7, 9, 12
Self-Refresh Exit	SRX	L	H	H	V	V	V	V	V	V	V	V	7, 8, 9, 12
				L	H	H	H						
Single Bank Precharge	PRE	H	H	L	L	H	L	BA	V	V	L	V	
Precharge All Banks	PREA	H	H	L	L	H	L	V	V	V	H	V	
Bank Activate	ACT	H	H	L	L	H	H	BA	Row Address				
Write (Fixed BL8 or BC4)	WR	H	H	L	H	L	L	BA	RFU	V	L	CA	
Write (BC4, on the Fly)	WRS4	H	H	L	H	L	L	BA	RFU	L	L	CA	
Write (BL8, on the Fly)	WRS8	H	H	L	H	L	L	BA	RFU	H	L	CA	
Write with Auto-Precharge (Fixed BL8 or BC4)	WRA	H	H	L	H	L	L	BA	RFU	V	H	CA	
Write with Auto-Precharge (BC4, on the Fly)	WRAS4	H	H	L	H	L	L	BA	RFU	L	H	CA	
Write with Auto-Precharge (BL8, on the Fly)	WRAS8	H	H	L	H	L	L	BA	RFU	H	H	CA	
Read (Fixed BL8 or BC4)	RD	H	H	L	H	L	H	BA	RFU	V	L	CA	
Read (BC4, on the Fly)	RDS4	H	H	L	H	L	H	BA	RFU	L	L	CA	
Read (BL8, on the Fly)	RDS8	H	H	L	H	L	H	BA	RFU	H	L	CA	
Read with Auto-Precharge (Fixed BL8 or BC4)	RDA	H	H	L	H	L	H	BA	RFU	V	H	CA	
Read with Auto-Precharge (BC4, on the Fly)	RDAS4	H	H	L	H	L	H	BA	RFU	L	H	CA	
Read with Auto-Precharge (BL8, on the Fly)	RDAS8	H	H	L	H	L	H	BA	RFU	H	H	CA	
No Operation	NOP	H	H	L	H	H	H	V	V	V	V	V	10
Device Deselected	DES	H	H	H	X	X	X	X	X	X	X	X	11
Power-Down Entry	PDE	H	L	L	H	H	H	V	V	V	V	V	6, 12
				H	V	V	V						
Power-Down Exit	PDX	L	H	L	H	H	H	V	V	V	V	V	6, 12
				H	V	V	V						
ZQ Calibration Long	ZQCL	H	H	L	H	H	L	X	X	X	H	X	
ZQ Calibration Short	ZQCS	H	H	L	H	H	L	X	X	X	L	X	

Command Truth Table Notes:

1. All DDR3 SDRAM commands are defined by states of \overline{CS} , \overline{RAS} , \overline{CAS} , \overline{WE} , and CKE at the rising edge of the clock. The MSB of BA, RA and CA are device density and configuration dependant.
2. \overline{RESET} command is enabled when Low, which will be used only for asynchronous reset, so \overline{RESET} must be maintained HIGH during any function.
3. Bank addresses (BA) determine which bank is to be operated upon. For (E)MRS, BA selects an (Extended) Mode Register.
4. "V" means "H or L (but a defined logic level)" and "X" means either "defined or undefined (like floating) logic level".
5. Burst reads or writes cannot be terminated or interrupted and Fixed/on-the-Fly BL will be defined by the MRS.
6. The Power-Down Mode does not perform any refresh operation.
7. The state of ODT does not affect the states described in this table. The ODT function is not available during Self-Refresh.
8. Self-Refresh Exit is asynchronous.
9. V_{REF} (Both V_{REFDQ} and V_{REFCA}) must be maintained during Self-Refresh operation.
10. The No Operation command should be used in cases when the DDR3 SDRAM is in an idle or wait state. The purpose of the No Operation command (NOP) is to prevent the DDR3 SDRAM from registering any unwanted commands between operations. A No Operation command will not terminate a previous operation that is still executing, such as a burst read and write cycle.
11. The Deselect command performs the same function as No Operation command.
12. Refer to the CKE Truth Table for more detail with CKE transition.

CKE Truth Table

- (a) Notes 1-7 apply to the entire CKE Truth Table.
 (b) CKE low is allowed only if tMRD and tMOD are satisfied.

Current State	CKE		Command (N) ³ RAS, CAS, WE, CS	Action (N) ³	Notes
	Previous Cycle (N-1)	Current Cycle (N)			
Power-Down	L	L	X	Maintain Power-Down	14, 15
	L	H	Deselect or NOP	Power-Down Exit	11, 14
Self-Refresh	L	L	X	Maintain Self-Refresh	15, 16
	L	H	Deselect or NOP	Self-Refresh Exit	8, 12, 16
Bank Activate	H	L	Deselect or NOP	Active Power-Down Entry	11, 13, 14
Reading	H	L	Deselect or NOP	Power-Down Entry	11, 13, 14, 17
Writing	H	L	Deselect or NOP	Power-Down Entry	11, 13, 14, 17
Precharging	H	L	Deselect or NOP	Power-Down Entry	11, 13, 14, 17
Refreshing	H	L	Deselect or NOP	Precharge Power-Down Entry	11
All Banks Idle	H	L	Deselect or NOP	Precharge Power-Down Entry	11, 13, 14, 18
		L	Refresh	Self-Refresh	9, 13, 18
For more details with all signals, see Command Truth Table on the previous pages.					10

Notes:

- CKE (N) is the logic state of CKE at clock edge N; CKE (N-1) was the state of CKE at the previous clock edge.
- Current state is defined as the state of the DDR3 SDRAM immediately prior to clock edge N.
- COMMAND (N) is the command registered at clock edge N, and ACTION (N) is a result of COMMAND (N), ODT is not included here.
- All states and sequences not shown are illegal or reserved unless explicitly described elsewhere in this document.
- The state of ODT does not affect the states described in this table. The ODT function is not available during Self-Refresh.
- CKE must be registered with the same value on t_{CKEmin} consecutive positive clock edges. CKE must remain at the valid input level the entire time it takes to achieve the t_{CKEmin} clocks of registration. Thus, after any CKE transition, CKE may not transition from its valid level during the time period of t_{IS} + t_{CKEmin} + t_{IH}.
- Deselect and NOP are defined in the Command Truth Table.
- On Self-Refresh Exit, Deselect or NOP commands must be issued on every clock edge occurring during the t_{XSS} period. Read or ODT commands may be issued only after t_{XSDLL} is satisfied.
- Self-Refresh mode can only be entered from the All Banks Idle state.
- Must be a legal command as defined in the Command Truth Table.
- Valid commands for Power-Down Entry and Exit are NOP and Deselect only.
- Valid commands for Self-Refresh Exit are NOP and Deselect only.
- Self-Refresh can not be entered during Read or Write operations.
- The Power-Down does not perform any refresh operations.
- "X" means "don't care" (including floating around V_{REF}) in Self-Refresh and Power-Down. It also applies to Address pins.
- V_{REF} (Both V_{REFDQ} and V_{REFCA}) must be maintained during Self-Refresh operation.
- If all banks are closed at the conclusion of the read, write or precharge command, then Precharge Power-Down is entered, otherwise Active Power-Down is entered.
- "Idle state" is defined as all banks are closed (t_{RP}, t_{DAL}, etc. satisfied), no data bursts are in progress, CKE is high, and all timings from previous operations are satisfied (t_{MRD}, t_{MOD}, t_{RFC}, t_{ZQinit}, t_{ZQoper}, t_{ZQCS}, etc.) as well as all Self-Refresh exit and Power-Down Exit parameters are satisfied (t_{XS}, t_{XP}, t_{XPDLL}, etc.).

Absolute Maximum Ratings

Absolute Maximum DC Ratings

Symbol	Parameter	Rating	Units	Notes
V _{DD}	Voltage on V _{DD} relative to V _{SS}	-0.4 ~ 1.975	V	1, 3
V _{DDQ}	Voltage on V _{DDQ} relative to V _{SS}	-0.4 ~ 1.975	V	1, 3
V _{IN} , V _{OUT}	Voltage on any pin relative to V _{SS}	-0.4 ~ 1.975	V	1
V _{DDSPD}	Voltage on V _{DDSPD} relative to V _{SS}	1.7 ~ 3.6	V	1
T _{STG}	Storage Temperature	-50 to +100	°C	1, 2

Notes:

- Stresses greater than those listed under “Absolute Maximum Ratings” may cause permanent damage to the device. This is a stress rating only and functional operation of the device at these or any other conditions above those indicated in the operational sections of this specification is not implied. Exposure to absolute maximum rating conditions for extended periods may affect reliability.
- Storage Temperature is the case surface temperature on the center/top side of the DRAM.
- V_{DD} and V_{DDQ} must be within 300 mV of each other at all times and V_{REF} must be not greater than 0.6*V_{DDQ}. When V_{DD} and V_{DDQ} are less than 500 mV; V_{REF} may be equal to or less than 300 mV.

Operating Temperature Range

Symbol	Parameter	Range	Units	Notes
T _{OPER}	Normal Operating Temperature Range (Case)	0 to 85	°C	1, 2
	Extended Operating Temperature Range (Optional)	85 to 95	°C	1, 3

Notes:

- Operating Temperature T_{OPER} is the case surface temperature on the center/top side of the DRAM.
- The Normal Temperature Range specifies the temperatures where all DRAM specifications will be supported. During operation, the DRAM case temperature must be maintained between 0°C and 85°C under all operating conditions.
- Some applications require operation of the DRAM in the Extended Temperature Range between 85°C and 95°C case temperature. Full specifications are supported in this range, but the following additional conditions apply:
 - Refresh commands must be doubled in frequency, therefore reducing the Refresh interval t_{REFI} to 3.9µs. It is also possible to specify a component with 1X refresh (t_{REFI} to 7.8µs) in the Extended Temperature Range. Please refer to the SPD for option availability.
 - If Self-Refresh operation is required in the Extended Temperature Range, then it is mandatory to either use the Manual Self-Refresh mode with Extended Temperature Range capability (MR2 A6 = 0b and MR2 A7 = 1b) or enable the optional Auto Self-Refresh mode (MR2 A6 = 1b and MR2 A7 = 0b). Please refer to the SPD for option availability.



Recommended DC Operating Conditions

Symbol	Parameter	Voltage	Rating			Units	Notes
			Min	Typ	Max		
V _{DD}	Supply Voltage	1.35V	1.2825	1.35	1.45	V	1, 2, 3
		1.5V	1.425	1.5	1.575	V	1, 2, 3
V _{DDQ}	Supply Voltage for Output	1.35V	1.2825	1.35	1.45	V	1, 2, 3
		1.5V	1.425	1.5	1.575	V	1, 2, 3
V _{DDSPD}	SPD Supply Voltage		3.0	3.3	3.6	V	
V _{TT}	SPD Supply Voltage		0.7125	0.75	0.7875	V	4
V _{SS}	Ground		0	0	0	V	

Notes:

- Under all conditions, V_{DDQ} must be less than or equal to V_{DD}.
- V_{DDQ} tracks with V_{DD}. AC parameters are measured with V_{DD} and V_{DDQ} tied together.
- V_{DD} & V_{DDQ} rating are determined by operation voltage.
- V_{TT} = V_{DDQ}/2

AC and DC Logic Input Levels for Single-Ended Signals

Symbol	Parameter	DDR3-1066, & 1333		Units	Notes
		Min	Max		
1.35V					
V _{IH(DC)}	DC input logic high	V _{REF} + 0.90	V _{DD}	V	1
V _{IL(DC)}	DC input logic low	V _{SS}	V _{REF} - 0.90	V	1
V _{IH(AC)}	AC input logic high	V _{REF} + 0.160	-	V	1
V _{IL(AC)}	AC input logic low	-	V _{REF} - 0.160	V	1
1.5V					
V _{IH(DC)}	DC input logic high	V _{REF} + 0.100	V _{DD}	V	1
V _{IL(DC)}	DC input logic low	V _{SS}	V _{REF} - 0.100	V	1
V _{IH(AC)}	AC input logic high	V _{REF} + 0.175	-	V	1
V _{IL(AC)}	AC input logic low	-	V _{REF} - 0.175	V	1

Notes:

- For DQ and DM, V_{REF} = V_{REFDQ}. For input only pins except RESET#, V_{REF} = V_{REFCA}.
- The ac peak noise on V_{REF} may not allow V_{REF} to deviate from V_{REF(DC)} by more than ±1% V_{DD} (for reference: approx. ±15mV).
- For reference: approx. V_{DD}/2 ± 15mV.

Differential Swing Requirements for Clock ($\overline{CK/CK}$) and Strobe ($\overline{DQS/DQS}$)

Symbol	Parameter	DDR3-1066, & 1333		Units	Notes
		Min	Max		
V_{IHDIFF}	Differential input logic high	0.200	Note 3	V	1
V_{ILDIFF}	Differential input logic high	Note 3	-0.200	V	1
$V_{IHDIFF(AC)}$	AC input logic high	$2 * (V_{IH(AC)} - V_{REF})$	Note 3	V	2
$V_{ILDIFF(AC)}$	AC input logic low	Note 3	$2 * (V_{REF} - V_{IL(AC)})$	V	2

Notes:

- Used to define a differential signal slew-rate.
- For $\overline{CK/CK}$, use $V_{IH}/V_{IL(AC)}$ of ADD/CMD and V_{REFCA} ; for $\overline{DQS/DQS}$, use $V_{IH}/V_{IL(AC)}$ of DQs and V_{REFDQ} ; if a reduced AC-high or AC-low level is used for a signal group, then the reduced level applies also here.
- These values are not defined, however the single-ended signals \overline{CK} , \overline{CK} , \overline{DQS} , \overline{DQS} need to be within the respective limits ($V_{IH(DC)max}$, $V_{IL(DC)min}$) for single-ended signals as well as the limitations for overshoot and undershoot.

Single-ended Input Slew Rate Definition

Description	Measured		Defined by	Applicable for
	from	to		
Input slew rate for rising edge	V_{REF}	$V_{IL(AC)min}$	$\frac{V_{IH(AC)min} - V_{REF}}{\Delta TRS}$	Setup (t_{IS} , t_{DS})
Input slew rate for falling edge	V_{REF}	$V_{IL(AC)max}$	$\frac{V_{REF} - V_{IL(AC)max}}{\Delta TFS}$	
Input slew rate for rising edge	$V_{IL(DC)max}$	V_{REF}	$\frac{V_{REF} - V_{IL(DC)max}}{\Delta TFH}$	Hold (t_{IH} , t_{DH})
Input slew rate for falling edge	$V_{IL(DC)min}$	V_{REF}	$\frac{V_{IH(DC)min} - V_{REF}}{\Delta TRH}$	

Input/Output Capacitance (1.35V)

Speed Bin		DDR3-1066		DDR3-1333		Units	Notes
Parameter	Symbol	Min	Max	Min	Max		
Input/output capacitance (DQ, DM, DQS, \overline{DQS} , TDQS, \overline{TDQS})	C_{IO}	3	5	TBD	TBD	pF	1, 2
Input/output capacitance delta, (DQ, DM, DQS, \overline{DQS} , TDQS, \overline{TDQS})	C_{DIO}	-1	0.6	TBD	TBD	pF	2, 11
Input/output capacitance delta (DQS and \overline{DQS})	C_{DDQS}	0	0.4	TBD	TBD	pF	2, 4
Input capacitance, (CK and \overline{CK})	C_{CK}	6.4	12.8	TBD	TBD	pF	2
Input capacitance delta, (CK and \overline{CK})	C_{DCK}	0	1.6	TBD	TBD	pF	2, 3
Input capacitance, (ADD, CMD input- only pins)	$C_{I_ADD_}$ C_{I_CMD}	12	20.8	TBD	TBD	pF	2, 6
Input capacitance delta, (All ADD/CMD input-only pins)	$C_{DI_ADD_}$ C_{DI_CMD}	-8	8	TBD	TBD	pF	2, 9, 10
Input capacitance, (CTRL input-only pins)	C_{I_CTRL}	6	10.4	TBD	TBD	pF	2, 5
Input capacitance delta, (All CTRL input-only pins)	C_{DI_CTRL}	-4	2.4	TBD	TBD	pF	2, 7, 8

Notes:

1. Although the DM, TDQS and \overline{TDQS} pins have different functions, the loading matches DQ and DQS.
2. This parameter is not subject to production test. It is verified by design and characterization.
3. Absolute value of $C_{CK} - C_{\overline{CK}}$
4. Absolute value of $C_{IO}(DQS) - C_{IO}(\overline{DQS})$
5. C_{I_CNTL} applies to ODT, \overline{CS} , CKE.
6. $C_{I_ADD_CMD}$ applies to A0-A15, BA0-BA2, \overline{RAS} , \overline{CAS} , \overline{WE} .
7. C_{DI_CTRL} applies to ODT, \overline{CS} and CKE
8. $C_{DI_CTRL} = C_{I}(CTRL) - 0.5 * (C_{I}(CK) + C_{I}(\overline{CK}))$
9. $C_{DI_ADD_CMD}$ applies to A0-A15, BA0-BA2, \overline{RAS} , \overline{CAS} and \overline{WE}
10. $C_{DI_ADD_CMD} = C_{I}(ADD_CMD) - 0.5 * (C_{I}(CK) + C_{I}(\overline{CK}))$
11. $C_{DIO} = C_{IO}(DQ,DM) - 0.5 * (C_{IO}(DQS) + C_{IO}(\overline{DQS}))$

Input/Output Capacitance (1.5V)

Speed Bin		DDR3-1066		DDR3-1333		Units	Notes
Parameter	Symbol	Min	Max	Min	Max		
Input/output capacitance (DQ, DM, DQS, $\overline{\text{DQS}}$, TDQS, $\overline{\text{TDQS}}$)	C_{IO}	3	5.4	3	5	pF	1, 2
Input/output capacitance delta, (DQ, DM, DQS, $\overline{\text{DQS}}$, TDQS, $\overline{\text{TDQS}}$)	C_{DIO}	-1	0.6	-1	0.6	pF	2, 11
Input/output capacitance delta (DQS and $\overline{\text{DQS}}$)	C_{DDQS}	0	0.4	0	0.3	pF	2, 4
Input capacitance, (CK and $\overline{\text{CK}}$)	C_{CK}	6.4	12.8	6.4	11.2	pF	2
Input capacitance delta, (CK and $\overline{\text{CK}}$)	C_{DCK}	0	1.6	0	1.6	pF	2, 3
Input capacitance, (ADD, CMD input- only pins)	$C_{\text{I_ADD_CMD}}$	12	24	12	24	pF	2, 6
Input capacitance delta, (All ADD/CMD input-only pins)	$C_{\text{DI_ADD_CMD}}$	-8	8	-6.4	6.4	pF	2, 9, 10
Input capacitance, (CTRL input-only pins)	$C_{\text{I_CTRL}}$	6	12	6	10.4	pF	2, 5
Input capacitance delta, (All CTRL input-only pins)	$C_{\text{DI_CTRL}}$	-4	2.4	-4	2.4	pF	2, 7, 8

Notes:

- Although the DM, TDQS and $\overline{\text{TDQS}}$ pins have different functions, the loading matches DQ and DQS.
- This parameter is not subject to production test. It is verified by design and characterization.
- Absolute value of $C_{\text{CK}} - C_{\overline{\text{CK}}}$
- Absolute value of $C_{\text{IO}}(\text{DQS}) - C_{\text{IO}}(\overline{\text{DQS}})$
- $C_{\text{I_CNTL}}$ applies to ODT, $\overline{\text{CS}}$, CKE.
- $C_{\text{I_ADD_CMD}}$ applies to A0-A15, BA0-BA2, $\overline{\text{RAS}}$, $\overline{\text{CAS}}$, $\overline{\text{WE}}$.
- $C_{\text{DI_CTRL}}$ applies to ODT, $\overline{\text{CS}}$ and CKE
- $C_{\text{DI_CTRL}} = C_{\text{I}}(\text{CTRL}) - 0.5 * (C_{\text{I}}(\text{CK}) + C_{\text{I}}(\overline{\text{CK}}))$
- $C_{\text{DI_ADD_CMD}}$ applies to A0-A15, BA0-BA2, $\overline{\text{RAS}}$, $\overline{\text{CAS}}$ and $\overline{\text{WE}}$
- $C_{\text{DI_ADD_CMD}} = C_{\text{I}}(\text{ADD_CMD}) - 0.5 * (C_{\text{I}}(\text{CK}) + C_{\text{I}}(\overline{\text{CK}}))$
- $C_{\text{DIO}} = C_{\text{IO}}(\text{DQ,DM}) - 0.5 * (C_{\text{IO}}(\text{DQS}) + C_{\text{IO}}(\overline{\text{DQS}}))$

IDD and IDDQ Measurement-Loop Patterns Timing

Speed Bin	DDR3-1066	DDR3-1333	Units
Parameter	7-7-7	9-9-9	
t _{CKmin} (IDD)	1.875	1.5	ns
CL(IDD)	7	9	nCK
nRCD	7	9	nCK
nRC	27	33	nCK
nRAS	20	24	nCK
nRP	7	9	nCK
nFAW	20	20	nCK
nRRD	6	5	nCK
nRFC	59	74	nCK

Definitions for IDD Measurement Conditions

- “0” and “LOW” is defined as $V_{IN} \leq V_{ILAC(max)}$.
- “1” and “HIGH” is defined as $V_{IN} \geq V_{IHAC(min)}$.
- “MID-LEVEL” is defined as inputs that are $V_{REF} = V_{DD}/2$.
- Timings used for IDD and IDDQ Measurement-Loop Patterns are provided in IDD and IDDQ Timings on page 27.
- Basic IDD and IDDQ Measurement Conditions are described in IDD Measurement Conditions on pages 28-30.
- Detailed IDD and IDDQ Measurement-Loop Patterns are described in IDD Measurement-Loop Patterns on pages 31-36.
- IDD Measurements are done after properly initializing the DDR3 SDRAM. This includes but is not limited to setting:
 - RON = RZQ/7 (34 Ohm in MR1);
 - Qoff = 0_B (Output Buffer enabled in MR1);
 - RTT_Nom = RZQ/6 (40 Ohm in MR1);
 - RTT_Wr = RZQ/2 (120 Ohm in MR2);
 - TDQS Feature disabled in MR1.
- **Attention:** The IDD and IDDQ Measurement-Loop Patterns need to be executed at least one time before actual IDD or IDDQ measurement is started.
- Define $\underline{D} = \{\overline{CS}, \overline{RAS}, \overline{CAS}, \overline{WE}\} = \{HIGH, LOW, LOW, LOW\}$
- Define $\overline{D} = \{\overline{CS}, \overline{RAS}, \overline{CAS}, \overline{WE}\} = \{HIGH, HIGH, HIGH, HIGH\}$



IDD Measurement Conditions

Symbol	Description	Conditions
I _{DD0}	Operating One Bank Active-Precharge Current	CKE: High; External clock: On; tCK, nRC, nRAS, CL: See IDD and IDDQ Timings on page 27; BL: 8 ¹ ; AL: 0; \overline{CS} : High between ACT and PRE; Command, Address, Bank Address Inputs: partially toggling according to IDD0 Measurement-Loop Pattern on page 31; Data I/O: MID-LEVEL; DM: stable at 0; Bank Activity: Cycling with one bank active at a time: 0,0,1,1,2,2,... (See IDD0 Measurement-Loop Pattern on page 31); Output Buffer and RTT: Enabled in Mode Registers ² ; ODT Signal: stable at 0; Pattern Details: See IDD0 Measurement-Loop Pattern on page 31.
I _{DD1}	Operating One Bank Active-Read-Precharge Current	CKE: High; External clock: On; tCK, nRC, nRAS, nRCD, CL: See IDD and IDDQ Timings on page 27; BL: 8 ^{1, 6} ; AL: 0; \overline{CS} : High between ACT, RD and PRE; Command, Address, Bank Address Inputs, Data I/O: partially toggling according to IDD1 Measurement-Loop Pattern on page 32; DM: stable at 0; Bank Activity: Cycling with one bank active at a time: 0,0,1,1,2,2,... (See IDD1 Measurement-Loop Pattern on page 32); Output Buffer and RTT: Enabled in Mode Registers ² ; ODT Signal: stable at 0; Pattern Details: See IDD1 Measurement-Loop Pattern on page 32.
I _{DD2P0}	Precharge Power-Down Current Slow Exit	CKE: Low; External clock: On; tCK, CL: See IDD and IDDQ Timings on page 27; BL: 8 ¹ ; AL: 0; \overline{CS} : stable at 1; Command, Address, Bank Address Inputs: stable at 0; Data I/O: MID-LEVEL; DM: stable at 0; Bank Activity: all banks closed; Output Buffer and RTT: Enabled in Mode Registers ² ; ODT Signal: stable at 0; Precharge Power Down Mode: Slow Exit ³ .
I _{DD2P1}	Precharge Power-Down Current Fast Exit	CKE: Low; External clock: On; tCK, CL: See IDD and IDDQ Timings on page 27; BL: 8 ¹ ; AL: 0; \overline{CS} : stable at 1; Command, Address, Bank Address Inputs: stable at 0; Data I/O: MID-LEVEL; DM: stable at 0; Bank Activity: all banks closed; Output Buffer and RTT: Enabled in Mode Registers ² ; ODT Signal: stable at 0; Precharge Power Down Mode: Fast Exit ³ .
I _{DD2Q}	Precharge Quiet Standby Current	CKE: High; External clock: On; tCK, CL: See IDD and IDDQ Timings on page 27; BL: 8 ¹ ; AL: 0; \overline{CS} : stable at 1; Command, Address, Bank Address Inputs: stable at 0; Data I/O: MID-LEVEL; DM: stable at 0; Bank Activity: all banks closed; Output Buffer and RTT: Enabled in Mode Registers ² ; ODT Signal: stable at 0.
I _{DD2N}	Precharge Standby Current	CKE: High; External clock: On; tCK, CL: See IDD and IDDQ Timings on page 27; BL: 8 ¹ ; AL: 0; \overline{CS} : stable at 1; Command, Address, Bank Address Inputs: partially toggling according to IDD2N and IDD3N Measurement-Loop Pattern on page 33; Data I/O: MID-LEVEL; DM: stable at 0; Bank Activity: all banks closed; Output Buffer and RTT: Enabled in Mode Registers ² ; ODT Signal: stable at 0; Pattern Details: See IDD2N and IDD3N Measurement-Loop Pattern on page 33.



IDD Measurement Conditions (Contd.)

Symbol	Description	Conditions
I _{DD2NT}	Precharge Standby ODT Current	CKE: High; External clock: On; tCK, CL: See IDD and IDDQ Timings on page 27; BL: 8 ¹ ; AL: 0; \overline{CS} : stable at 1; Command, Address, Bank Address Inputs: partially toggling according to IDD2NT Measurement-Loop Pattern on page 33; Data I/O: MID-LEVEL; DM: stable at 0; Bank Activity: all banks closed; Output Buffer and RTT: Enabled in Mode Registers ² ; ODT Signal: toggling according to IDD2NT Measurement-Loop Pattern on page 33; Pattern Details: See IDD2NT Measurement-Loop Pattern on page 33.
I _{DD3P}	Active Power Down Current	CKE: Low; External clock: On; tCK, CL: See IDD and IDDQ Timings on page 27; BL: 8 ¹ ; AL: 0; \overline{CS} : stable at 1; Command, Address, Bank Address Inputs: stable at 0; Data I/O: MID-LEVEL; DM: stable at 0; Bank Activity: all banks open; Output Buffer and RTT: Enabled in Mode Registers ² ; ODT Signal: stable at 0.
I _{DD3N}	Active Standby Current	CKE: High; External clock: On; tCK, CL: See IDD and IDDQ Timings on page 27; BL: 8 ¹ ; AL: 0; \overline{CS} : stable at 1; Command, Address, Bank Address Inputs: partially toggling according to IDD2N and IDD3N Measurement-Loop Pattern on page 33; Data I/O: MID-LEVEL; DM: stable at 0; Bank Activity: all banks open; Output Buffer and RTT: Enabled in Mode Registers ² ; ODT Signal: stable at 0; Pattern Details: See IDD2N and IDD3N Measurement-Loop Pattern on page 33.
I _{DD4R}	Operating Burst Read Current	CKE: High; External clock: On; tCK, CL: See IDD and IDDQ Timings on page 27; BL: 8 ^{1, 6} ; AL: 0; \overline{CS} : High between RD; Command, Address, Bank Address Inputs: partially toggling according to IDD4R Measurement-Loop Pattern on page 34; Data I/O: seamless read data burst with different data between one burst and the next one according to IDD4R Measurement-Loop Pattern on page 34; DM: stable at 0; Bank Activity: all banks open, RD commands cycling through banks: 0,0,1,1,2,2,... (See IDD4R Measurement-Loop Pattern on page 34); Output Buffer and RTT: Enabled in Mode Registers ² ; ODT Signal: stable at 0; Pattern Details: See IDD4R Measurement-Loop Pattern on page 34.
I _{DD4W}	Operating Burst Write Current	CKE: High; External clock: On; tCK, CL: See IDD and IDDQ Timings on page 27; BL: 8 ¹ ; AL: 0; \overline{CS} : High between WR; Command, Address, Bank Address Inputs: partially toggling according to IDD4W Measurement-Loop Pattern on page 34; Data I/O: seamless write data burst with different data between one burst and the next one according to IDD4W Measurement-Loop Pattern on page 34; DM: stable at 0; Bank Activity: all banks open, WR commands cycling through banks: 0,0,1,1,2,2,... (See IDD4W Measurement-Loop Pattern on page 34); Output Buffer and RTT: Enabled in Mode Registers ² ; ODT Signal: stable at HIGH; Pattern Details: See IDD4W Measurement-Loop Pattern on page 34.



IDD Measurement Conditions (Contd.)

Symbol	Description	Conditions
I _{DD5B}	Burst Refresh Current	CKE: High; External clock: On; tCK, CL, nRFC: See IDD and IDDQ Timings on page 27; BL: 8 ¹ ; AL: 0; \overline{CS} : High between REF; Command, Address, Bank Address Inputs: partially toggling according to IDD5B Measurement-Loop Pattern on page 35; Data I/O: MID-LEVEL; DM: stable at 0; Bank Activity: REF command every nRFC (See IDD5B Measurement-Loop Pattern on page 35); Output Buffer and RTT: Enabled in Mode Registers ² ; ODT Signal: stable at 0; Pattern Details: See IDD5B Measurement-Loop Pattern on page 35.
I _{DD6}	Self-Refresh Current: Normal Temperature Range	T _{CASE} : 0 - 85°C; Auto Self-Refresh (ASR): Disabled ⁴ ; Self-Refresh Temperature Range (SRT): Normal ⁵ ; CKE: Low; External clock: Off; CK and CK#: LOW; CL: See IDD and IDDQ Timings on page 27; BL: 8 ¹ ; AL: 0; \overline{CS} , Command, Address, Bank Address, Data I/O: MID-LEVEL; DM: stable at 0; Bank Activity: Self-Refresh operation; Output Buffer and RTT: Enabled in Mode Registers ² ; ODT Signal: MID-LEVEL.
I _{DD6ET}	Self-Refresh Current: Extended Temperature Range	T _{CASE} : 85 - 95°C; Auto Self-Refresh (ASR): Disabled ⁴ ; Self-Refresh Temperature Range (SRT): Extended ⁵ ; CKE: Low; External clock: Off; CK and CK#: LOW; CL: See IDD and IDDQ Timings on page 27; BL: 8 ¹ ; AL: 0; \overline{CS} , Command, Address, Bank Address, Data I/O: MID-LEVEL; DM: stable at 0; Bank Activity: Extended Temperature Self-Refresh operation; Output Buffer and RTT: Enabled in Mode Registers ² ; ODT Signal: MID-LEVEL.
I _{DD7}	All Bank Interleave Read Current	CKE: High; External clock: On; tCK, nRC, nRAS, nRCD, nRRD, nFAW, CL: See IDD and IDDQ Timings on page 27; BL: 8 ¹ , 6; AL: CL-1; \overline{CS} : High between ACT and RDA; Command, Address, Bank Address Inputs: partially toggling according to IDD7 Measurement-Loop Pattern on page 35; Data I/O: read data bursts with different data between one burst and the next one according to IDD7 Measurement-Loop Pattern on page 35; DM: stable at 0; Bank Activity: two times interleaved cycling through banks (0, 1,...7) with different addressing, See IDD7 Measurement-Loop Pattern on page 35; Output Buffer and RTT: Enabled in Mode Registers ² ; ODT Signal: stable at 0; Pattern Details: See IDD7 Measurement-Loop Pattern on page 35.

Notes:

1. Burst Length: BL8 fixed by MRS: set MR0 A[1,0]=00B.
2. Output Buffer Enable: set MR1 A[12] = 0B; set MR1 A[5,1] = 01B; RTT_Nom enable: set MR1 A[9,6,2] = 011B; RTT_Wr enable: set MR2 A[10,9] = 10B.
3. Precharge Power Down Mode: set MR0 A[12] = 0B for Slow Exit or MR0 A[12]=1B for Fast Exit.
4. Auto Self-Refresh (ASR): set MR2 A[6] = 0B to disable or 1B to enable feature.
5. Self-Refresh Temperature Range (SRT): set MR2 A[7] = 0B for normal or 1B for extended temperature range.
6. Read Burst Type: Nibble Sequential, set MR0 A[3] = 0B.



IDD Measurement Conditions (Contd.)

IDD0 Measurement-Loop Pattern¹

CK, CK	CKE	Sub-Loop	Cycle Number	Command	CS	RAS	CAS	WE	ODT	BA[2:0]	A[15:11]	A[10]	A[9:7]	A[6:3]	A[2:0]	Data ²		
toggling	Static High	0	0	ACT	0	0	1	1	0	0	00	0	0	0	0	-		
			1, 2	D, D	1	0	0	0	0	0	0	00	0	0	0	0	-	
			3, 4	$\overline{D}, \overline{D}$	1	1	1	1	0	0	0	00	0	0	0	0	-	
			...	Repeat pattern 1-4 until nRAS - 1. Truncate if necessary														
			nRAS	PRE	0	0	1	0	0	0	0	00	0	0	0	0	-	
			...	Repeat pattern 1-4 until nRC - 1. Truncate if necessary														
			1*nRC + 0	ACT	0	0	1	1	0	0	0	00	0	0	F	0	-	
			1*nRC + 1, 2	D, D	1	0	0	0	0	0	0	00	0	0	F	0	-	
			1*nRC + 3, 4	$\overline{D}, \overline{D}$	1	1	1	1	0	0	0	00	0	0	F	0	-	
			...	Repeat pattern nRC + 1-4 until 1*nRC + nRAS - 1. Truncate if necessary														
			1*nRC + nRAS	PRE	0	0	1	0	0	0	0	00	0	0	F	0	-	
			...	Repeat pattern nRC + 1-4 until 2*nRC - 1. Truncate if necessary														
		1	2*nRC	Repeat Sub-Loop 0, but BA[2:0] = 1														
		2	4*nRC	Repeat Sub-Loop 0, but BA[2:0] = 2														
		3	6*nRC	Repeat Sub-Loop 0, but BA[2:0] = 3														
		4	8*nRC	Repeat Sub-Loop 0, but BA[2:0] = 4														
		5	10*nRC	Repeat Sub-Loop 0, but BA[2:0] = 5														
		6	12*nRC	Repeat Sub-Loop 0, but BA[2:0] = 6														
		7	14*nRC	Repeat Sub-Loop 0, but BA[2:0] = 7														

Notes:

- DM must be driven LOW all the time. DQS, \overline{DQS} are MID-LEVEL.
- DQ signals are MID-LEVEL.



IDD Measurement Conditions (Contd.)

IDD1 Measurement-Loop Pattern¹

CK, CK	CKE	Sub-Loop	Cycle Number	Command	CS	RAS	CAS	WE	ODT	BA[2:0]	A[15:11]	A[10]	A[9:7]	A[6:3]	A[2:0]	Data ²		
toggling	Static High	0	0	ACT	0	0	1	1	0	0	00	0	0	0	0	-		
			1-2	D, D	1	0	0	0	0	0	0	00	0	0	0	0	-	
			3-4	D, D	1	1	1	1	0	0	0	00	0	0	0	0	-	
			...	Repeat pattern 1-4 until nRCD - 1. Truncate if necessary														
			nRCD	RD	0	1	0	1	0	0	0	00	0	0	0	0	0	0000000
			...	Repeat pattern 1-4 until nRAS - 1. Truncate if necessary														
			nRAS	PRE	0	0	1	0	0	0	0	00	0	0	0	0	0	-
			...	Repeat pattern 1-4 until nRC - 1. Truncate if necessary														
			1*nRC + 0	ACT	0	0	1	1	0	0	00	0	0	0	F	0	-	
			1*nRC + 1-2	D, D	1	0	0	0	0	0	00	0	0	0	F	0	-	
			1*nRC + 3-4	D, D	1	1	1	1	0	0	00	0	0	0	F	0	-	
			...	Repeat pattern nRC + 1-4 until 1*nRC + nRCD - 1. Truncate if necessary														
			1*nRC + nRCD	RD	0	1	0	1	0	0	00	0	0	0	F	0	00110011	
			...	Repeat pattern nRC + 1-4 until 1*nRC + nRAS - 1. Truncate if necessary														
		1*nRC + nRAS	PRE	0	0	1	0	0	0	00	0	0	0	F	0	-		
		...	Repeat pattern nRC + 1-4 until 2*nRC - 1. Truncate if necessary															
		1	2*nRC	Repeat Sub-Loop 0, but BA[2:0] = 1														
		2	4*nRC	Repeat Sub-Loop 0, but BA[2:0] = 2														
		3	6*nRC	Repeat Sub-Loop 0, but BA[2:0] = 3														
		4	8*nRC	Repeat Sub-Loop 0, but BA[2:0] = 4														
		5	10*nRC	Repeat Sub-Loop 0, but BA[2:0] = 5														
6	12*nRC	Repeat Sub-Loop 0, but BA[2:0] = 6																
7	14*nRC	Repeat Sub-Loop 0, but BA[2:0] = 7																

Notes:

- DM must be driven LOW all the time. DQS, \overline{DQS} are used according to RD Commands, otherwise MID-LEVEL.
- Burst Sequence driven on each DQ signal by Read Command. Outside burst operation, DQ signals are MID-LEVEL.



IDD Measurement Conditions (Contd.)

IDD2N and IDD3N Measurement-Loop Pattern

CK, CK	CKE	Sub-Loop	Cycle Number	Command	CS	RAS	CAS	WE	ODT	BA[2:0]	A[15:11]	A[10]	A[9:7]	A[6:3]	A[2:0]	Data ²		
toggling	Static High	0	0	D	1	0	0	0	0	0	00	0	0	0	0	-		
			1	D	1	0	0	0	0	0	0	00	0	0	0	0	-	
			2	D	1	1	1	1	1	0	0	00	0	0	F	0	-	
			3	D	1	1	1	1	1	0	0	00	0	0	F	0	-	
		1	4-7	Repeat Sub-Loop 0, but BA[2:0] = 1														
		2	8-11	Repeat Sub-Loop 0, but BA[2:0] = 2														
		3	12-15	Repeat Sub-Loop 0, but BA[2:0] = 3														
		4	16-19	Repeat Sub-Loop 0, but BA[2:0] = 4														
		5	20-23	Repeat Sub-Loop 0, but BA[2:0] = 5														
		6	24-27	Repeat Sub-Loop 0, but BA[2:0] = 6														
		7	28-31	Repeat Sub-Loop 0, but BA[2:0] = 7														

IDD2NT Measurement-Loop Pattern

CK, CK	CKE	Sub-Loop	Cycle Number	Command	CS	RAS	CAS	WE	ODT	BA[2:0]	A[15:11]	A[10]	A[9:7]	A[6:3]	A[2:0]	Data ²		
toggling	Static High	0	0	D	1	0	0	0	0	0	00	0	0	0	0	-		
			1	D	1	0	0	0	0	0	0	00	0	0	0	0	-	
			2	D	1	1	1	1	1	0	0	00	0	0	F	0	-	
			3	D	1	1	1	1	1	0	0	00	0	0	F	0	-	
		1	4-7	Repeat Sub-Loop 0, but ODT = 0 and BA[2:0] = 1														
		2	8-11	Repeat Sub-Loop 0, but ODT = 1 and BA[2:0] = 2														
		3	12-15	Repeat Sub-Loop 0, but ODT = 1 and BA[2:0] = 3														
		4	16-19	Repeat Sub-Loop 0, but ODT = 0 and BA[2:0] = 4														
		5	20-23	Repeat Sub-Loop 0, but ODT = 0 and BA[2:0] = 5														
		6	24-27	Repeat Sub-Loop 0, but ODT = 1 and BA[2:0] = 6														
		7	28-31	Repeat Sub-Loop 0, but ODT = 1 and BA[2:0] = 7														

Notes:

- DM must be driven LOW all the time. DQS, $\overline{\text{DQS}}$ are MID-LEVEL.
- DQ signals are MID-LEVEL.



IDD Measurement Conditions (Contd.)

IDD4R Measurement-Loop Pattern¹

CK, CK	CKE	Sub-Loop	Cycle Number	Command	CS	RAS	CAS	WE	ODT	BA[2:0]	A[15:11]	A[10]	A[9:7]	A[6:3]	A[2:0]	Data ²	
toggling	Static High	0	0	RD	0	1	0	1	0	0	00	0	0	0	0	00000000	
			1	D	1	0	0	0	0	0	0	00	0	0	0	0	-
			2-3	$\overline{D}, \overline{D}$	1	1	1	1	0	0	0	00	0	0	0	0	-
			4	RD	0	1	0	1	0	0	0	00	0	0	F	0	00110011
			5	D	1	0	0	0	0	0	0	00	0	0	F	0	-
			6-7	$\overline{D}, \overline{D}$	1	1	1	1	0	0	0	00	0	0	F	0	-
		1	8-15	Repeat Sub-Loop 0, but BA[2:0] = 1													
		2	16-23	Repeat Sub-Loop 0, but BA[2:0] = 2													
		3	24-31	Repeat Sub-Loop 0, but BA[2:0] = 3													
		4	32-39	Repeat Sub-Loop 0, but BA[2:0] = 4													
		5	40-47	Repeat Sub-Loop 0, but BA[2:0] = 5													
		6	48-55	Repeat Sub-Loop 0, but BA[2:0] = 6													
		7	56-63	Repeat Sub-Loop 0, but BA[2:0] = 7													

IDD4W Measurement-Loop Pattern¹

CK, CK	CKE	Sub-Loop	Cycle Number	Command	CS	RAS	CAS	WE	ODT	BA[2:0]	A[15:11]	A[10]	A[9:7]	A[6:3]	A[2:0]	Data ²	
toggling	Static High	0	0	WR	0	1	0	0	1	0	00	0	0	0	0	00000000	
			1	D	1	0	0	0	1	0	00	0	0	0	0	-	
			2-3	$\overline{D}, \overline{D}$	1	1	1	1	1	0	00	0	0	0	0	-	
			4	WR	0	1	0	0	1	0	00	0	0	F	0	00110011	
			5	D	1	0	0	0	1	0	00	0	0	F	0	-	
			6-7	$\overline{D}, \overline{D}$	1	1	1	1	1	0	00	0	0	F	0	-	
		1	8-15	Repeat Sub-Loop 0, but BA[2:0] = 1													
		2	16-23	Repeat Sub-Loop 0, but BA[2:0] = 2													
		3	24-31	Repeat Sub-Loop 0, but BA[2:0] = 3													
		4	32-39	Repeat Sub-Loop 0, but BA[2:0] = 4													
		5	40-47	Repeat Sub-Loop 0, but BA[2:0] = 5													
		6	48-55	Repeat Sub-Loop 0, but BA[2:0] = 6													
		7	56-63	Repeat Sub-Loop 0, but BA[2:0] = 7													

Notes:

- DM must be driven LOW all the time. DQS, \overline{DQS} are MID-LEVEL.
- DQ signals are MID-LEVEL.



IDD Measurement Conditions (Contd.)

IDD5B Measurement-Loop Pattern¹

CK, CK	CKE	Sub-Loop	Cycle Number	Command	CS	RAS	CAS	WE	ODT	BA[2:0]	A[15:11]	A[10]	A[9:7]	A[6:3]	A[2:0]	Data ²	
toggling	Static High	0	0	REF	0	0	0	1	0	0	00	0	0	0	0	-	
		1	1-2	D	1	0	0	0	0	0	0	00	0	0	0	0	-
			3-4	D	1	1	1	1	1	0	0	00	0	0	F	0	-
			5-8	Repeat cycles 1-4, but BA[2:0] = 1													
			9-12	Repeat cycles 1-4, but BA[2:0] = 2													
			13-16	Repeat cycles 1-4, but BA[2:0] = 3													
			17-20	Repeat cycles 1-4, but BA[2:0] = 4													
			21-24	Repeat cycles 1-4, but BA[2:0] = 5													
			25-28	Repeat cycles 1-4, but BA[2:0] = 6													
			29-32	Repeat cycles 1-4, but BA[2:0] = 7													
		2	33-nRFC - 1	Repeat Sub-Loop 1 until nRFC - 1. Truncate if necessary													

IDD7 Measurement-Loop Pattern¹

ATTENTION: Sub-Loops 10-19 have inverse A[6:3] Pattern and Data Pattern than Sub-Loops 0-9

CK, CK	CKE	Sub-Loop	Cycle Number	Command	CS	RAS	CAS	WE	ODT	BA[2:0]	A[15:11]	A[10]	A[9:7]	A[6:3]	A[2:0]	Data ²	
toggling	Static High	0	0	ACT	0	0	1	1	0	0	00	0	0	0	0	-	
			1	RDA	0	1	0	1	0	0	00	1	0	0	0	00000000	
			2	D	1	0	0	0	0	0	0	00	0	0	0	0	-
			...	Repeat above D Command until nRRD - 1													
		1	nRRD	ACT	0	0	1	1	0	1	00	0	0	F	0	-	
			nRRD + 1	RDA	0	1	0	1	0	1	00	1	0	F	0	00110011	
			nRRD + 2	D	1	0	0	0	0	0	1	00	0	0	F	0	-
		...	Repeat above D Command until 2*nRRD - 1														
		2	2*nRRD	Repeat Sub-Loop 0, but BA[2:0] = 2													
		3	3*nRRD	Repeat Sub-Loop 1, but BA[2:0] = 3													
		4	4*nRRD	D	1	0	0	0	0	0	3	00	0	0	F	0	-
Assert and repeat above D Command until nFAW - 1, if necessary																	



IDD Measurement Conditions (Contd.)

IDD7 Measurement-Loop Pattern (Contd.)¹

ATTENTION: Sub-Loops 10-19 have inverse A[6:3] Pattern and Data Pattern than Sub-Loops 0-9

CK, CK	CKE	Sub-Loop	Cycle Number	Command	CS	RAS	CAS	WE	ODT	BA[2:0]	A[15:11]	A[10]	A[9:7]	A[6:3]	A[2:0]	Data ²	
		5	nFAW	Repeat Sub-Loop 0, but BA[2:0] = 4													
		6	nFAW + nRRD	Repeat Sub-Loop 1, but BA[2:0] = 5													
		7	nFAW + 2*nRRD	Repeat Sub-Loop 0, but BA[2:0] = 6													
		8	nFAW + 3*nRRD	Repeat Sub-Loop 1, but BA[2:0] = 7													
toggling	Static High	9	nFAW + 4*nRRD	D	1	0	0	0	0	7	00	0	0	F	0	-	
			Assert and repeat above D Command until 2*nFAW - 1, if necessary														
		10	2*nFAW	ACT	0	0	1	1	0	0	0	00	0	0	F	0	-
			2*nFAW + 1	RDA	0	1	0	1	0	0	0	00	1	0	F	0	00110011
			2*nFAW + 2	D	1	0	0	0	0	0	0	00	0	0	F	0	-
		Repeat above D Command until 2*nFAW + nRRD - 1															
		11	2*nFAW + nRRD	ACT	0	0	1	1	0	1	00	0	0	0	0	0	-
			2*nFAW + nRRD + 1	RDA	0	1	0	1	0	1	00	1	0	0	0	0	00000000
			2*nFAW + nRRD + 2	D	1	0	0	0	0	0	1	00	0	0	0	0	-
		Repeat above D Command until 2*nFAW + 2*nRRD - 1															
		12	2*nFAW + 2*nRRD	Repeat Sub-Loop 10, but BA[2:0] = 2													
		13	2*nFAW + 3*nRRD	Repeat Sub-Loop 11, but BA[2:0] = 3													
		14	2*nFAW + 4*nRRD	D	1	0	0	0	0	3	00	0	0	0	0	0	-
				Assert and repeat above D Command until 3*nFAW - 1, if necessary													
		15	3*nFAW	Repeat Sub-Loop 10, but BA[2:0] = 4													
		16	3*nFAW + nRRD	Repeat Sub-Loop 11, but BA[2:0] = 5													
		17	3*nFAW + 2*nRRD	Repeat Sub-Loop 10, but BA[2:0] = 6													
18	3*nFAW + 3*nRRD	Repeat Sub-Loop 11, but BA[2:0] = 7															
19	3*nFAW + 4*nRRD	D	1	0	0	0	0	7	00	0	0	0	0	0	-		
		Assert and repeat above D Command until 4*nFAW - 1, if necessary															

Notes:

- DM must be driven LOW all the time. DQS, \overline{DQS} are used according to RD Commands, otherwise MID-LEVEL
- Burst Sequence driven on each DQ signal by Read Command. Outside burst operation, DQ signals are MID-LEVEL.



IDD Specifications

Speed Bin	DDR3-1066		DDR3-1333		Units	Notes
	7-7-7		9-9-9			
Parameter	1.35V	1.5V	1.35V	1.5V		
I _{DD0}	1080	1280	1240	1400	mA	
I _{DD1}	1200	1440	1360	1560	mA	
I _{DD2P0}	160	192	160	192	mA	
I _{DD2P1}	400	560	480	640	mA	
I _{DD2Q}	720	848	880	960	mA	
I _{DD2N}	720	880	880	1040	mA	
I _{DD2NT}	560	1200	640	1360	mA	
I _{DD3P}	640	760	776	840	mA	
I _{DD3N}	800	960	960	1040	mA	
I _{DD4R}	1360	1760	1640	2120	mA	
I _{DD4W}	1360	2000	1640	2280	mA	
I _{DD5B}	1800	2240	1960	2440	mA	
I _{DD6}	160	160	160	160	mA	
I _{DD6ET}	192	192	192	192	mA	
I _{DD7}	2720	3600	3360	4440	mA	

Refresh Parameters

Parameter	Symbol	1Gb	Units
REF command to ACT or REF command time	t_{RFC}	110	ns
Average periodic refresh interval	$0\text{ }^{\circ}\text{C} \leq T_{CASE} \leq 85\text{ }^{\circ}\text{C}$	7.8	μs
	$85\text{ }^{\circ}\text{C} \leq T_{CASE} \leq 95\text{ }^{\circ}\text{C}$	3.9	μs

Device Standard Speed Bins

DDR3-1066 Speed Bins

Speed Bin		DDR3-1066		Units	Notes	
CL - nRCD - nRP		7-7-7				
Parameter	Symbol	Min	Max			
Internal read command to first data	t_{AA}	13.125	20	ns		
ACT to internal read or write delay time	t_{RCD}	13.125	-	ns		
Pre command period	t_{RP}	13.125	-	ns		
ACT to ACT or REF command period	t_{RC}	50.625	-	ns		
ACT to PRE command period	t_{RAS}	37.5	$9 * t_{REFI}$	ns		
CL = 5	CWL = 5	$t_{CK(avg)}$	3.0	3.3	ns	1, 2, 3, 5, 7
	CWL = 6	$t_{CK(avg)}$	Reserved		ns	4
CL = 6	CWL = 5	$t_{CK(avg)}$	2.5	3.3	ns	1, 2, 3, 5
	CWL = 6	$t_{CK(avg)}$	Reserved		ns	4
CL = 7	CWL = 5	$t_{CK(avg)}$	Reserved		ns	4
	CWL = 6	$t_{CK(avg)}$	1.875	< 2.5	ns	1, 2, 3
CL = 8	CWL = 5	$t_{CK(avg)}$	Reserved		ns	4
	CWL = 6	$t_{CK(avg)}$	1.875	< 2.5	ns	1, 2, 3
Supported CL Settings		5, 6, 7, 8		n_{CK}		
Supported CWL Settings		5, 6		n_{CK}		

Device Standard Speed Bins (Contd.)
DDR3-1333 Speed Bins

Speed Bin		DDR3-1333		Units	Notes	
CL - nRCD - nRP		9-9-9				
Parameter	Symbol	Min	Max			
Internal read command to first data		t_{AA}	13.125	20	ns	
ACT to internal read or write delay time		t_{RCD}	13.125	-	ns	
Pre command period		t_{RP}	13.125	-	ns	
ACT to ACT or REF command period		t_{RC}	49.125	-	ns	
ACT to PRE command period		t_{RAS}	36	$9 * t_{REFI}$	ns	
CL = 5	CWL = 5	$t_{CK(avg)}$	3.0	3.3	ns	1, 2, 3, 6, 7
	CWL = 6, 7		Reserved		ns	4
CL = 6	CWL = 5	$t_{CK(avg)}$	2.5	3.3	ns	1, 2, 3, 6
	CWL = 6, 7		Reserved		ns	4
CL = 7	CWL = 5	$t_{CK(avg)}$	Reserved		ns	4
	CWL = 6		1.875	< 2.5	ns	1, 2, 3, 6
	CWL = 7		Reserved		ns	4
CL = 8	CWL = 5	$t_{CK(avg)}$	Reserved		ns	4
	CWL = 6		1.875	< 2.5	ns	1, 2, 3, 6
	CWL = 7		Reserved		ns	4
CL = 9	CWL = 5, 6	$t_{CK(avg)}$	Reserved		ns	4
	CWL = 7		1.5	< 1.875	ns	1, 2, 3
Supported CL Settings			5, 6, 7, 8, 9		n _{CK}	
Supported CWL Settings			5, 6, 7		n _{CK}	



Speed Bin Tables Notes

1. The CL setting and CWL setting result in $t_{CK(AVG)min}$ and $t_{CK(AVG)max}$ requirements. When making a selection of $t_{CK(AVG)}$, both need to be fulfilled: Requirements from CL setting as well as requirements from CWL setting.
2. $t_{CK(AVG)min}$ limits: Since \overline{CAS} Latency is not purely analog - data and strobe output are synchronized by the DLL - all possible intermediate frequencies may not be guaranteed. An application should use the next smaller JEDEC standard $t_{CK(AVG)}$ value (2.5, 1.875, or 1.5) when calculating $CL [nCK] = t_{AA} [ns] / t_{CK(AVG)} [ns]$, rounding up to the next 'Supported CL'.
3. $t_{CK(AVG)max}$ limits: Calculate $t_{CK(AVG)} = t_{AAmax} / CL \text{ SELECTED}$ and round the resulting $t_{CK(AVG)}$ down to the next valid speed bin (i.e. 3.3ns, 2.5ns, or 1.875 ns). This result is $t_{CK(AVG)max}$ corresponding to CL SELECTED.
4. 'Reserved' settings are not allowed. User must program a different value.
5. Any DDR3-1066 speed bin also supports functional operation at lower frequencies as shown in the table which are not subject to Production Tests but verified by Design/Characterization.
6. Any DDR3-1333 speed bin also supports functional operation at lower frequencies as shown in the table which are not subject to Production Tests but verified by Design/Characterization.
7. DDR3-800 AC timing apply if DRAM operates at lower than 800 MT/s data rate.

Device Timing Parameters by Speed Bin

Parameter	Symbol	DDR3-1066		DDR3-1333		Units	Notes
		Min	Max	Min	Max		
Clock Timing							
Minimum clock cycle time (DLL off mode)	t _{CK(DLL_OFF)}	8	-	8	-	t _{CK}	6
Average clock period	t _{CK(avg)}	Refer to Speed Bin on pages 38-39.				ps	
Average high pulse width	t _{CH(avg)}	0.47	0.53	0.47	0.53	t _{CK(avg)}	
Average low pulse width	t _{CL(avg)}	0.47	0.53	0.47	0.53	t _{CK(avg)}	
Absolute clock period	t _{CK(abs)}	t _{CK(avg)min} + t _{JIT(per)min}	t _{CK(avg)max} + t _{JIT(per)max}	t _{CK(avg)min} + t _{JIT(per)min}	t _{CK(avg)max} + t _{JIT(per)max}	ps	
Absolute clock high pulse width	t _{CH(abs)}	0.43	-	0.43	-	t _{CK(avg)}	25
Absolute clock low pulse width	t _{CL(abs)}	0.43	-	0.43	-	t _{CK(avg)}	26
Clock period jitter	t _{JIT(per)}	-90	90	-80	80	ps	
Clock period jitter during DLL locking period	t _{JIT(per, lck)}	-80	80	-70	70	ps	
Cycle to cycle period jitter	t _{JIT(CC)}	180		160		ps	
Cycle to cycle period jitter during DLL locking period	t _{JIT(CC, lck)}	160		140		ps	
Duty cycle jitter	t _{JIT(duty)}	-	-	-	-	ps	
Cumulative error across 2 cycles	t _{ERR(2per)}	-132	132	-118	118	ps	
Cumulative error across 3 cycles	t _{ERR(3per)}	-157	157	-140	140	ps	
Cumulative error across 4 cycles	t _{ERR(4per)}	-175	175	-155	155	ps	
Cumulative error across 5 cycles	t _{ERR(5per)}	-188	188	-168	168	ps	
Cumulative error across 6 cycles	t _{ERR(6per)}	-200	200	-177	177	ps	
Cumulative error across 7 cycles	t _{ERR(7per)}	-209	209	-186	186	ps	
Cumulative error across 8 cycles	t _{ERR(8per)}	-217	217	-193	193	ps	
Cumulative error across 9 cycles	t _{ERR(9per)}	-224	224	-200	200	ps	
Cumulative error across 10 cycles	t _{ERR(10per)}	-231	231	-205	205	ps	
Cumulative error across 11 cycles	t _{ERR(11per)}	-237	237	-210	210	ps	
Cumulative error across 12 cycles	t _{ERR(12per)}	-242	242	-215	215	ps	
Cumulative error across n = 13-50 cycles	t _{ERR(nper)}	$t_{ERR(nper)min} = (1 + 0.68\ln(n)) * t_{JIT(per)min}$ $t_{ERR(nper)max} = (1 + 0.68\ln(n)) * t_{JIT(per)max}$				ps	24



Device Timing Parameters by Speed Bin (Contd.)

Parameter	Symbol	DDR3-1066		DDR3-1333		Units	Notes
		Min	Max	Min	Max		
Data Timing							
DQS, \overline{DQS} to DQ skew, per group, per access	t_{DQSQ}	-	150	-	125	ps	13
DQ output hold time from DQS, \overline{DQS}	t_{QH}	0.38	-	0.38	-	$t_{CK(avg)}$	13, b
DQ low-impedance from CK, \overline{CK}	$t_{LZ}(DQ)$	-600	300	-500	250	ps	13, 14, a
DQ high-impedance from CK, \overline{CK}	$t_{HZ}(DQ)$	-	300	-	250	ps	13, 14, a
Data setup time to DQS, DQS referenced to $V_{IH(AC)} / V_{IL(AC)}$ levels	$t_{DS}^{(base)}$ AC175	25	-	-	-	ps	17, d
Data setup time to DQS, DQS referenced to $V_{IH(AC)} / V_{IL(AC)}$ levels	$t_{DS}^{(base)}$ AC150	75	-	30	-	ps	17, d
Data hold time from DQS, DQS referenced to $V_{IH(DC)} / V_{IL(DC)}$ levels	$t_{DH}^{(base)}$ DC100	100	-	65	-	ps	17, d
DQ and DM input pulse width for each input	t_{DIPW}	490	-	400	-	ps	28
Data Strobe Timing							
DQS, \overline{DQS} differential READ preamble	t_{RPRE}	0.9	Note 19	0.9	Note 19	$t_{CK(avg)}$	13, 19, b
DQS, \overline{DQS} differential READ postamble	t_{RPST}	0.3	Note 11	0.3	Note 11	$t_{CK(avg)}$	11, 13, b
DQS, \overline{DQS} differential output high time	t_{QSH}	0.38	-	0.4	-	$t_{CK(avg)}$	13, b
DQS, \overline{DQS} differential output low time	t_{QSL}	0.38	-	0.4	-	$t_{CK(avg)}$	13, b
DQS, \overline{DQS} differential WRITE preamble	t_{WPRE}	0.9	-	0.9	-	$t_{CK(avg)}$	
DQS, \overline{DQS} differential WRITE postamble	t_{WPST}	0.3	-	0.3	-	$t_{CK(avg)}$	
DQS, DQS rising edge output access time from rising CK, \overline{CK}	t_{DQSCK}	-300	300	-255	255	ps	13, a
DQS and \overline{DQS} low-impedance time (Referenced from RL - 1)	$t_{LZ}(DQS)$	-600	300	-500	250	ps	13, 14, a
DQS and \overline{DQS} low-impedance time (Referenced from RL + BL / 2)	$t_{HZ}(DQS)$	-	300	-	250	ps	13, 14, a
DQS, \overline{DQS} differential input low pulse width	t_{DQSL}	0.45	0.55	0.45	0.55	$t_{CK(avg)}$	
DQS, \overline{DQS} differential input high pulse width	t_{DQSH}	0.45	0.55	0.45	0.55	$t_{CK(avg)}$	
DQS, \overline{DQS} rising edge to CK, CK rising edge	t_{DQSS}	-0.25	0.25	-0.25	0.25	$t_{CK(avg)}$	c
DQS, \overline{DQS} falling edge setup time to CK, \overline{CK} rising edge	t_{DSS}	0.2	-	0.2	-	$t_{CK(avg)}$	c
DQS, \overline{DQS} falling edge hold time from CK, CK rising edge	t_{DSH}	0.2	-	0.2	-	$t_{CK(avg)}$	c

Device Timing Parameters by Speed Bin (Contd.)

Parameter	Symbol	DDR3-1066		DDR3-1333		Units	Notes
		Min	Max	Min	Max		
Command and Address Timing							
DLL locking time	t _{DLLK}	512	-	512	-	nCK	
Internal READ command to PRE-CHARGE command delay	t _{RTP}	max (4nCK, 7.5ns)	-	max (4nCK, 7.5ns)	-		e
Delay from start of internal write transaction to internal READ command	t _{WTR}	max (4nCK, 7.5ns)	-	max (4nCK, 7.5ns)	-		18, e
WRITE recovery time	t _{WR}	15	-	15	-	ns	e
Mode Register Set command cycle time	t _{MRD}	4	-	4	-	nCK	
Mode Register Set command update delay	t _{MOD}	max (12nCK, 15ns)	-	max (12nCK, 15ns)	-		
ACT to internal read or write delay time	t _{RCD}	Refer to Speed Bin on pages 38-39.					e
PRECHARGE command period	t _{RP}	Refer to Speed Bin on pages 38-39.					e
ACT to ACT or REF command period	t _{RC}	Refer to Speed Bin on pages 38-39.					e
CAS to CAS command delay	t _{CCD}	4	-	4	-	nCK	
Auto-precharge write recovery + pre-charge time	t _{DAL(min)}	WR + roundup (t _{RP} / t _{CK(avg)})		WR + roundup (t _{RP} / t _{CK(avg)})		nCK	
Multi-purpose register recovery time	t _{MPPRR}	1	-	1	-	nCK	22
ACTIVE to PRECHARGE command period	t _{RAS}	Refer to Speed Bin on pages 38-39.					e
ACTIVE to ACTIVE command period for 1KB page size	t _{RRD}	max (4nCK, 7.5ns)	-	max (4nCK, 6ns)	-		e
Four activate window for 1KB page size	t _{FAW}	37.5	-	30	-	ns	e
Command and Address setup time to CK, CK referenced to V _{IH(AC)} / V _{IL(AC)} levels	t _{IS(base) AC175}	125	-	65	-	ps	16, b
Command and Address setup time to CK, CK referenced to V _{IH(AC)} / V _{IL(AC)} levels	t _{IS(base) AC150}	275	-	190	-	ps	16, 27, b
Command and Address hold time to CK, CK referenced to V _{IH(DC)} / V _{IL(DC)} levels	t _{IH(base) DC100}	200	-	140	-	ps	16, b
Control and address input pulse width for each input	t _{IPW}	780	-	620	-	ps	28
Calibration Timing							
Power-up and RESET calibration time	t _{ZQinit}	max (512nCK, 640ns)	-	max (512nCK, 640ns)	-		
Normal operation Full calibration time	t _{ZQoper}	max (256nCK, 320ns)	-	max (256nCK, 320ns)	-		
Normal operation Short calibration time	t _{ZQCS}	max (64nCK, 80ns)	-	max (64nCK, 80ns)	-		23

Device Timing Parameters by Speed Bin (Contd.)

Parameter	Symbol	DDR3-1066		DDR3-1333		Units	Notes
		Min	Max	Min	Max		
Reset Timing							
Exit Reset from CKE HIGH to a valid command	t_{XPR}	max (5nCK, $t_{RFC}(\text{min}) + 10\text{ns}$)	-	max (5nCK, $t_{RFC}(\text{min}) + 10\text{ns}$)	-		
Self Refresh Timing							
Exit Self Refresh from to commands not requiring a locked DLL	t_{XS}	max (5nCK, $t_{RFC}(\text{min}) + 10\text{ns}$)	-	max (5nCK, $t_{RFC}(\text{min}) + 10\text{ns}$)	-		
Exit Self Refresh from to commands requiring a locked DLL	t_{XSDLL}	$t_{DLLK}(\text{min})$	-	$t_{DLLK}(\text{min})$	-	nCK	
Minimum CKE low width for Self Refresh entry to exit timing	t_{CKESR}	$t_{CKE}(\text{min}) + 1\text{nCK}$	-	$t_{CKE}(\text{min}) + 1\text{nCK}$	-		
Valid clock requirement after Self Refresh Entry (SRE) or Power-Down Entry (PDE)	t_{CKSRE}	max (5nCK, 10ns)	-	max (5nCK, 10ns)	-		
Valid clock requirement before Self Refresh Exit (SRX) or Power-Down Exit (PDX) or Reset Exit	t_{CKSRX}	max (5nCK, 10ns)	-	max (5nCK, 10ns)	-		
Power Down Timing							
Exit Power Down with DLL on to any valid command; Exit Precharge Power Down with DLL frozen to commands not requiring a locked DLL	t_{XP}	max (3nCK, 7.5ns)	-	max (3nCK, 6ns)	-		
Exit Precharge Power Down with DLL frozen to commands requiring a locked DLL	t_{XPDLL}	max (10nCK, 24ns)	-	max (10nCK, 24ns)	-		2
CKE minimum pulse width	t_{CKE}	max (3nCK, 5.625ns)	-	max (3nCK, 5.625ns)	-	nCK	
Command pass disable delay	t_{CPDED}	1	-	1	-	nCK	
Power Down Entry to Exit Timing	t_{PD}	$t_{CKE}(\text{min})$	$9 * t_{REFI}$	$t_{CKE}(\text{min})$	$9 * t_{REFI}$		15
Timing of ACT command to Power Down entry	$t_{ACTPDEN}$	1	-	1	-	nCK	20
Timing of PRE or PREA command to Power Down entry	t_{PRPDEN}	1	-	1	-	nCK	20
Timing of RD/RDA command to Power Down entry	t_{RDPDEN}	$RL + 4 + 1$	-	$RL + 4 + 1$	-	nCK	



Device Timing Parameters by Speed Bin (Contd.)

Parameter	Symbol	DDR3-1066		DDR3-1333		Units	Notes
		Min	Max	Min	Max		
Timing of WR command to Power Down entry (BL8OTF, BL8MRS, BC4OTF)	t _{WRPDEN}	WL + 4 + (t _{WR} / t _{CK(avg)})	-	WL + 4 + (t _{WR} / t _{CK(avg)})	-	nCK	9
Timing of WRA command to Power Down entry (BL8OTF, BL8MRS, BC4OTF)	t _{WRAPDEN}	WL + 4 + WR + 1	-	WL + 4 + WR + 1	-	nCK	10
Timing of WR command to Power Down entry (BC4MRS)	t _{WRPDEN}	WL + 2 + (t _{WR} / t _{CK(avg)})	-	WL + 2 + (t _{WR} / t _{CK(avg)})	-	nCK	9
Timing of WRA command to Power Down entry (BC4MRS)	t _{WRAPDEN}	WL + 2 + WR + 1	-	WL + 2 + WR + 1	-	nCK	10
Timing of REF command to Power Down entry	t _{REFPDEN}	1	-	1	-	nCK	20, 21
Timing of MRS command to Power Down entry	t _{MRSPDEN}	t _{MOD} (min)	-	t _{MOD} (min)	-		
ODT Timing							
ODT turn on latency	ODTLon	WL-2 = CWL + AL -2		WL-2 = CWL + AL -2		nCK	
ODT turn off latency	ODTloff	WL-2 = CWL + AL -2		WL-2 = CWL + AL -2		nCK	
ODT high time without Write command or with Write command and BC4	ODTH4	4	-	4	-	nCK	
ODT high time with Write command and BL8	ODTH8	6	-	6	-	nCK	
Asynchronous RTT turn-on delay (Power-Down with DLL frozen)	t _{AONPD}	2	8.5	2	8.5	ns	
Asynchronous RTT turn-off delay (Power-Down with DLL frozen)	t _{AOFFPD}	2	8.5	2	8.5	ns	
RTT turn-on	t _{AON}	-300	300	-250	250	ps	7, a
RTT_Nom and RTT_WR turn-off time from ODTloff reference	t _{AOF}	0.3	0.7	0.3	0.7	t _{CK(avg)}	8, a
RTT dynamic change skew	t _{ADC}	0.3	0.7	0.3	0.7	t _{CK(avg)}	a
Write Leveling Timing							
First DQS/DQS rising edge after write leveling mode is programmed	t _{WLMRD}	40	-	40	-	nCK	3
DQS/DQS delay after write leveling mode is programmed	t _{WLDQSEN}	25	-	25	-	nCK	3
Write leveling setup time from rising CK, CK crossing to rising DQS, DQS crossing	t _{WLS}	245	-	195	-	ps	
Write leveling hold time from rising DQS, DQS crossing to rising CK, CK crossing	t _{WLH}	245	-	195	-	ps	
Write leveling output delay	t _{WLO}	0	9	0	9	ns	
Write leveling output error	t _{WLOE}	0	2	0	2	ns	

Device Timing Parameters Notes

1. Actual value dependant upon measurement level definitions which are TBD.
2. Commands requiring a locked DLL are: READ (and RAP) and synchronous ODT commands.
3. The max values are system dependent.
4. WR as programmed in the Mode Register.
5. Value must be rounded-up to next higher integer value.
6. There is no maximum cycle time limit besides the need to satisfy the refresh interval, t_{REFI} .
7. Minimum RTT turn-on time (t_{AONmin}) is the point in time when the device leaves high impedance and ODT resistance begins to turn on. Maximum RTT turn on time (t_{AONmax}) is the point in time when the ODT resistance is fully on. Both are measured from ODTLon.
8. Minimum RTT turn-off time (t_{AOFmin}) is the point in time when the device starts to turn off the ODT resistance. Maximum RTT turn off time (t_{AOFmax}) is the point in time when the on-die termination has reached high impedance. Both are measured from ODTLoff.
9. t_{WR} is defined in ns, for calculation of t_{WRPDEN} it is necessary to round up t_{WR} / t_{CK} to the next integer.
10. WR is in clock cycles as programmed in MR0.
11. The maximum postamble is bound by $t_{HZDQS}(max)$.
12. Output timing deratings are relative to the SDRAM input clock. When the device is operated with input clock jitter, this parameter needs to be derated by TBD.
13. Value is only valid for RON34.
14. Single ended signal parameter.
15. t_{REFI} depends on T_{OPER} .
16. $t_{IS(base)}$ and $t_{IH(base)}$ values are for 1V/ns CMD/ADD single-ended slew rate and 2V/ns CK, \overline{CK} differential slew rate. Note for DQ and DM signals, $V_{REF(DC)} = V_{REFDQ(DC)}$. For input only pins except \overline{RESET} , $V_{REF(DC)} = V_{REFCA(DC)}$.
17. $t_{DS(base)}$ and $t_{DH(base)}$ values are for 1V/ns DQ single-ended slew rate and 2V/ns DQS, \overline{DQS} differential slew rate. Note for DQ and DM signals, $V_{REF(DC)} = V_{REFDQ(DC)}$. For input only pins except \overline{RESET} , $V_{REF(DC)} = V_{REFCA(DC)}$.
18. Start of internal write transaction is defined as follows:
 - For BL8 (fixed by MRS and on- the-fly): Rising clock edge 4 clock cycles after WL.
 - For BC4 (on- the- fly): Rising clock edge 4 clock cycles after WL.
 - For BC4 (fixed by MRS): Rising clock edge 2 clock cycles after WL.
19. The maximum preamble is bound by $t_{LZDQS}(min)$.
20. CKE is allowed to be registered low while operations such as row activation, precharge, auto-precharge or refresh are in progress, but power-down IDD spec will not be applied until finishing those operations.
21. Although CKE is allowed to be registered LOW after a REFRESH command once $t_{REFPDEN}(min)$ is satisfied, there are cases where additional time such as $t_{XPDDL}(min)$ is also required.
22. Defined between end of MPR read burst and MRS which reloads MPR or disables MPR function.
23. One ZQCS command can effectively correct a minimum of 0.5% (ZQ Correction) of RON and RTT impedance error within 64 nCK for all speed bins assuming the maximum sensitivities specified in the 'Output Driver Voltage and Temperature Sensitivity' and 'ODT Voltage and Temperature Sensitivity' tables. The appropriate interval between ZQCS commands can be determined from these tables and other application-specific parameters.
 One method for calculating the interval between ZQCS commands, given the temperature ($T_{driftrate}$) and voltage ($V_{driftrate}$) drift rates that the SDRAM is subject to in the application, is illustrated. The interval could be defined by the following formula:

$$\frac{ZQCorrection}{(TSens \times Tdriftrate) + (VSens \times Vdriftrate)}$$

where TSens = max (dRTTdT, dRONdTM) and VSens = max (dRTTdV, dRONdVM) define the SDRAM temperature and voltage sensitivities.

For example, if TSens = 1.5% / °C, VSens = 0.15% / mV, Tdriftrate = 1 °C / sec and Vdriftrate = 15 mV / sec, then the interval between ZQCS commands is calculated as:

$$\frac{0.5}{(1.5 \times 1) + (0.15 + 15)} = 0.133 \approx 128ms$$

24. n = from 13 cycles to 50 cycles. This row defines 38 parameters.
25. $t_{CH(abs)}$ is the absolute instantaneous clock high pulse width, as measured from one rising edge to the following falling edge.
26. $t_{CL(abs)}$ is the absolute instantaneous clock low pulse width, as measured from one falling edge to the following rising edge.
27. The $t_{IS(base)}$ AC150 specifications are adjusted from the $t_{IS(base)}$ specification by adding an additional 100 ps of derating to accommodate for the lower alternate threshold of 150 mV and another 25 ps to account for the earlier reference point $[(175mv - 150mV) / 1 V/ns]$.
28. Pulse width of a input signal is defined as the width between the first crossing of V_{REFDC} and the consecutive crossing of V_{REFDC} .

Jitter Notes

- a When the device is operated with input clock jitter, this parameter needs to be derated by the actual $t_{ERR(mper)act}$ of the input clock, where $2 \leq m \leq 12$. (Output deratings are relative to the SDRAM input clock.)

For example, if the measured jitter into a DDR3-800 SDRAM has $t_{ERR(mper)act, min} = -172$ ps and $t_{ERR(mper)act, max} = +193$ ps, then $t_{DQSCkmin} (derated) = t_{DQSCkmin} - t_{ERR(mper)act, max} = -400$ ps - 193 ps = -593 ps and $t_{DQSCkmax} (derated) = t_{DQSCkmax} - t_{ERR(mper)act, min} = 400$ ps + 172 ps = +572 ps. Similarly, $t_{LZ(DQ)}$ for DDR3-800 derates to $t_{LZ(DQ)min} (derated) = -800$ ps - 193 ps = -993 ps and $t_{LZ(DQ)max} (derated) = 400$ ps + 172 ps = +572 ps. (Caution on the min/max usage!)

Note that $t_{ERR(mper)act, min}$ is the minimum measured value of $t_{ERR(nper)}$ where $2 \leq n \leq 12$, and $t_{ERR(mper)act, max}$ is the maximum measured value of $t_{ERR(nper)}$ where $2 \leq n \leq 12$.

- b When the device is operated with input clock jitter, this parameter needs to be derated by the actual $t_{JIT(per),act}$ of the input clock. (Output deratings are relative to the SDRAM input clock.)

For example, if the measured jitter into a DDR3-800 SDRAM has $t_{CK(avg)act} = 2500$ ps, $t_{JIT(per)act, min} = -72$ ps and $t_{JIT(per)act, max} = +93$ ps, then $t_{RPREmin} (derated) = t_{RPREmin} + t_{JIT(per)act, min} = 0.9 \times t_{CK(avg)act} + t_{JIT(per)act, min} = 0.9 \times 2500$ ps - 72 ps = +2178 ps. Similarly, $t_{QHmin} (derated) = t_{QHmin} + t_{JIT(per)act, min} = 0.38 \times t_{CK(avg)act} + t_{JIT(per)act, min} = 0.38 \times 2500$ ps - 72 ps = +878 ps. (Caution on the min/max usage!)

- c These parameters are measured from a data strobe signal (DQS, \overline{DQS}) crossing to its respective clock signal (CK, \overline{CK}) crossing. The spec values are not affected by the amount of clock jitter applied (i.e. $t_{JIT(per)}$, $t_{JIT(CC)}$, etc.), as these are relative to the clock signal crossing. That is, these parameters should be met whether clock jitter is present or not.
- d These parameters are measured from a data signal ($DM, DQ0, DQ1, \text{etc.}$) transition edge to its respective data strobe signal (DQS, \overline{DQS}) crossing.
- e For these parameters, the DDR3 SDRAM device supports $t_{nPARAM} [nCK] = RU\{t_{PARAM} [ns] / t_{CK(avg)} [ns]\}$, which is in clock cycles, assuming all input clock jitter specifications are satisfied. For example, the device will support $t_{nRP} = RU\{t_{RP} / t_{CK(avg)}\}$, which is in clock cycles, if all input clock jitter specifications are met. This means: For DDR3-800 6-6-6, of which $t_{RP} = 15$ ns, the device will support $t_{nRP} = RU\{t_{RP} / t_{CK(avg)}\} = 6$, as long as the input clock jitter specifications are met, i.e. Precharge command at T_m and Active command at T_m+6 is valid even if $(T_m+6 - T_m)$ is less than 15 ns due to input clock jitter.

Part Number Decode

S	G	5	64	56	8	F	U	8	N	W	U	U
1	2	3	4	5	6	7	8	9	10	11	12	13

- 1 SMART Modular Technologies**
- 2 Module Process Technology**
G: Green Module (RoHS Compliant)
- 3 Product Category**
5: SDRAM DIMM with Standard Testing
- 4 Module Data Bus Width**
64: x64
- 5 Module Address Depth**
56: 256M
- 6 Device Data Width**
8: x8
- 7 Special Device Feature**
F: Standard FBGA (8 Bank SDRAM)
- 8 Technology and Voltage**
H: DDR3 SDRAM and 1.5V
J: DDR3 SDRAM and 1.35V/1.5V
- 9 Refresh and Power**
8: 8K Refresh and Standard Power
- 10 Module Configuration**
N: 200-pin SO-DIMM Unbuffered, Non-ECC
- 11 Device Physicals**
W: 1Gbit Device Based
- 12 CAS Latencies Supported**
L: 5, 6, 7, 8
P: 5, 6, 7, 8, 9
- 13 Cycle Time (Clock Speed)**
C: 1.875ns (533MHz, PC3-8500, DDR3-1066-777)
H: 1.5ns (667MHz, PC3-10600, DDR3-1333-999)

Note: "UU" in the part number should be replaced by user specified option.

Disclaimer:

No part of this document may be copied or reproduced in any form or by any means, or transferred to any third party, without the prior written consent of an authorized representative of SMART Modular Technologies, Inc. ("SMART"). The information in this document is subject to change without notice. SMART assumes no responsibility for any errors or omissions that may appear in this document, and disclaims responsibility for any consequences resulting from the use of the information set forth herein. SMART makes no commitments to update or to keep current information contained in this document. The products listed in this document are not suitable for use in applications such as, but not limited to, aircraft control systems, aerospace equipment, submarine cables, nuclear reactor control systems and life support systems. Moreover, SMART does not recommend or approve the use of any of its products in life support devices or systems or in any application where failure could result in injury or death. If a customer wishes to use SMART products in applications not intended by SMART, said customer must contact an authorized SMART representative to determine SMART's willingness to support a given application. The information set forth in this document does not convey any license under the copyrights, patent rights, trademarks or other intellectual property rights claimed and owned by SMART. The information set forth in this document is considered to be "Proprietary" and "Confidential" property owned by SMART.

ALL PRODUCTS SOLD BY SMART ARE COVERED BY THE PROVISIONS APPEARING IN SMART'S TERMS AND CONDITIONS OF SALE ONLY, INCLUDING THE LIMITATIONS OF LIABILITY, WARRANTY AND INFRINGEMENT PROVISIONS. SMART MAKES NO WARRANTIES OF ANY KIND, EXPRESS, STATUTORY, IMPLIED OR OTHERWISE, REGARDING INFORMATION SET FORTH HEREIN OR REGARDING THE FREEDOM OF THE DESCRIBED PRODUCTS FROM INTELLECTUAL PROPERTY INFRINGEMENT, AND EXPRESSLY DISCLAIMS ANY SUCH WARRANTIES INCLUDING WITHOUT LIMITATION ANY EXPRESS, STATUTORY OR IMPLIED WARRANTIES OF MERCHANTABILITY OR FITNESS FOR A PARTICULAR PURPOSE.

©1996 SMART Modular Technologies, Inc. All rights reserved.