



DuraMemory™

Module-In-A-Package™ (MIP™)

SMART Modular's MIP (Module In a Package) is a Tiny Form Factor (TFF) memory module that combines the benefits of industry standard SODIMMs with SMART's proprietary stacking technology. About the size of a nickel, SMART's MIP occupies 1/5th the area of a SODIMM while offering higher performance and lower power.

Key advantages of the MIP over SODIMMs include 42% power savings, 42% jitter reduction, and 39% PK/PK savings. These benefits are critical for applications such as broadcast video, mobile routing, high-end video/graphics cards and embedded computing applications where memory density in a small space is essential.

MIPs contain on-package address and control signal termination, eliminating the need in DRAM-down board usage scenarios. The MIP leverages SMART's extensive stacking technology into new markets and new applications. It addresses OEMs' need for faster memory in space-saving cube computing applications for networking, telecom and embedded markets.

Features & Benefits

- Occupies only 1/5th the space of an SODIMM
- Up to 42% power savings vs SODIMMs
- Superior ruggedness – soldered down; no sockets or clips
- Leverages SMART Modular's proven stacking technology

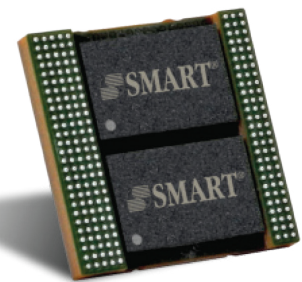

Applications

- Video Broadcast
- Video/Graphics Cards
- Embedded Computing
- Telecom
- Defense/Aerospace
- Automotive

Ordering Information

DDR4 MIP							
SMART Part Number	Density	Dimensions (mm)	Module Config	Device Config	Speed	Voltage	Temperature
ST2046MP42W625SA	16GB	22.25	2Gb x64	1Gx16	3200MT/s	1.2V	0°C to +70°C
ST2046MP42W614SA	16GB	22.25	2Gb x64	1Gx16	2933MT/s	1.2V	0°C to +70°C
ST1026MP41W693HC	8GB	22.25	1Gb x64	1Gx8	2666MT/s	1.2V	0°C to +70°C
ST1026MP41W672SB	8GB	22.25	1Gb x64	1Gx8	2400MT/s	1.2V	0°C to +70°C
ST5126MP451693SC	4GB	22.25	512Mb x64	512Mx16	2666MT/s	1.2V	0°C to +70°C
STT5126MP451693ME	4GB	22.25	512Mb x64	512Mx16	2666MT/s	1.2V	-40°C to +85°C
ST2566MP421693ND	2GB	22.25	256Mb x64	256Mx16	2666MT/s	1.2V	0°C to +70°C
STT2566MP421693ND	2GB	22.25	256Mb x64	256Mx16	2666MT/s	1.2V	-40°C to +85°C

DDR3 MIP							
SMART Part Number	Density	Dimensions (mm)	Module Config	Device Config	Speed	Voltage	Temperature
SP2566MP321638MP	2GB	22.25	256Mb x64	256Mx16	1866MT/s	1.35V	0°C to +70°C
SP2566MP321638SE	2GB	22.25	256Mb x64	256Mx16	1866MT/s	1.35V	0°C to +70°C
SPT2566MP321638NE	2GB	22.25	256Mb x64	256Mx16	1866MT/s	1.35V	-40°C to +85°C

MIP Layout

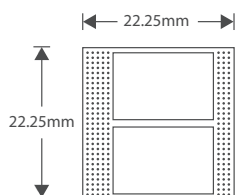

Layout 1

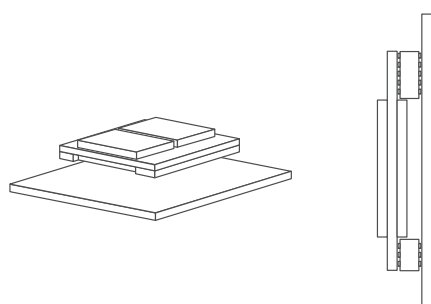

Layout 2

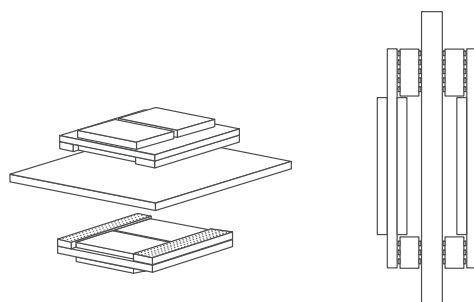

Layout 3

with ECC on opposite side of the MIP

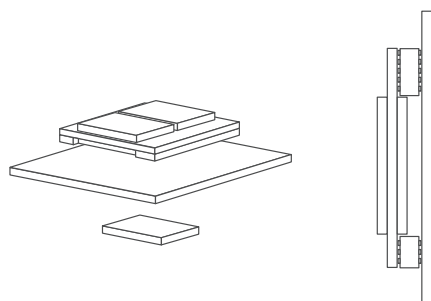

For more information, please visit: www.smartm.com

Headquarters/North America:

T: (+1) 800-956-7627 • T: (+1) 510-623-1231
F: (+1) 510-623-1434 • E: info@smartm.com

Latin America:

T: (+55) 11 4417-7200 • E: sales.br@smartm.com

Asia/Pacific:

T: (+65) 6678-7670 • E: sales.asia@smartm.com

EMEA:

T: (+44) 0 7826-064-745 • E: sales.euro@smartm.com

Customer Service:

T: (+1) 510-623-1231 • E: customers@smartm.com