

1 Products affected

Product hierarchy no. *				Part no.	SBU	Type / Description	Customer part no.
SBU	PG	PUG	Type				
02	007	003	0000002298	See list below	Appliance inlet	4798	

*SBU (2-digit) / PG (3-digit) / PUG (3-digit) / Type (10-digit)

List of part numbers affected

4798.9000	4798.9100	4798.9200		
-----------	-----------	-----------	--	--

2 Type of change

Change of marking.

3 Detailed description of change

The part number is no longer printed on the product.

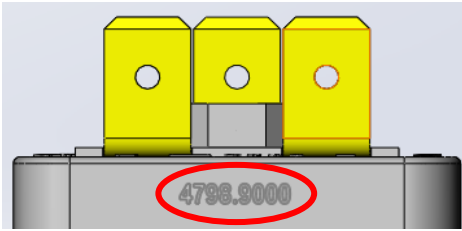
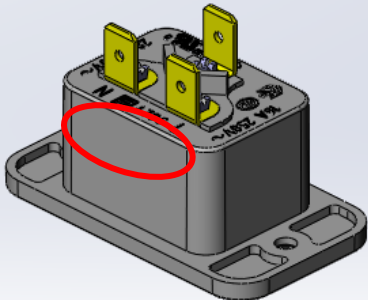
Old product appearance	New product appearance
	

4 Reason of change

Part number on product for identification not longer required.

5 Release date

The change will be rolled-out starting ww 06/2017 (Date code 1706 or higher on label) and lasts approx. 6 months depending on the variant.

6 Impact of change and recommended action

Form	Yes	Change of lettering
Fit	No	No change for dimension
Function	No	No change in function
Manufacturing	No	No change for manufacturing site
Label	No	No change on label
Packaging	No	No change in packaging

7 Reference Documents / Attachments

Kind of document	Remarks
Data Sheet 4798	

Product Change Notification					PCN 4798		D10-009-969
owner	creation date	release date	released by	change order no	rev	page	
hotzar	2016-10-20	2017-02-08	buerglal	2011292	A	1 of 1	