

LOW POWER SINGLE BIPOLAR OPERATIONAL AMPLIFIERS

- GOOD CONSUMPTION/SPEED RATIO : ONLY 200 μ A FOR 2.1MHz, 2V/ μ s
- SINGLE (OR DUAL) SUPPLY OPERATION FROM +4V TO +44V (\pm 2V TO \pm 22V)
- WIDE INPUT COMMON MODE VOLTAGE RANGE INCLUDING V_{CC}^-
- LOW LEVEL OUTPUT VOLTAGE CLOSE TO V_{CC}^- : 100mV TYPICAL
- PIN TO PIN COMPATIBLE WITH STANDARD SINGLE OP AMPs

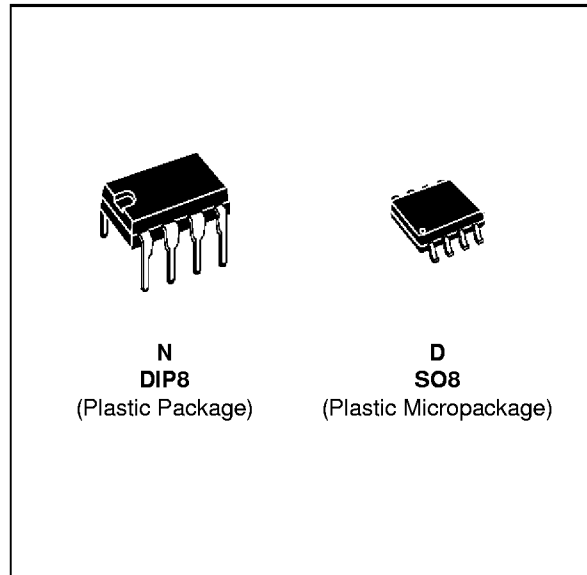

DESCRIPTION

The MC33171 series are single bipolar operational amplifiers offering both low consumption (200 μ A) and good speed (2.1MHz, 2V/ μ s).

Moreover the Input Common Mode Range extends down to the lower supply rail, allowing single supply operation from +4V to +44V.

ORDER CODES

Part Number	Temperature Range	Package	
		N	D
MC33171	-40°C, +105°C	•	•
MC35171	-55°C, +125°C	•	•

Example: MC33171N

PIN CONNECTIONS (top view)

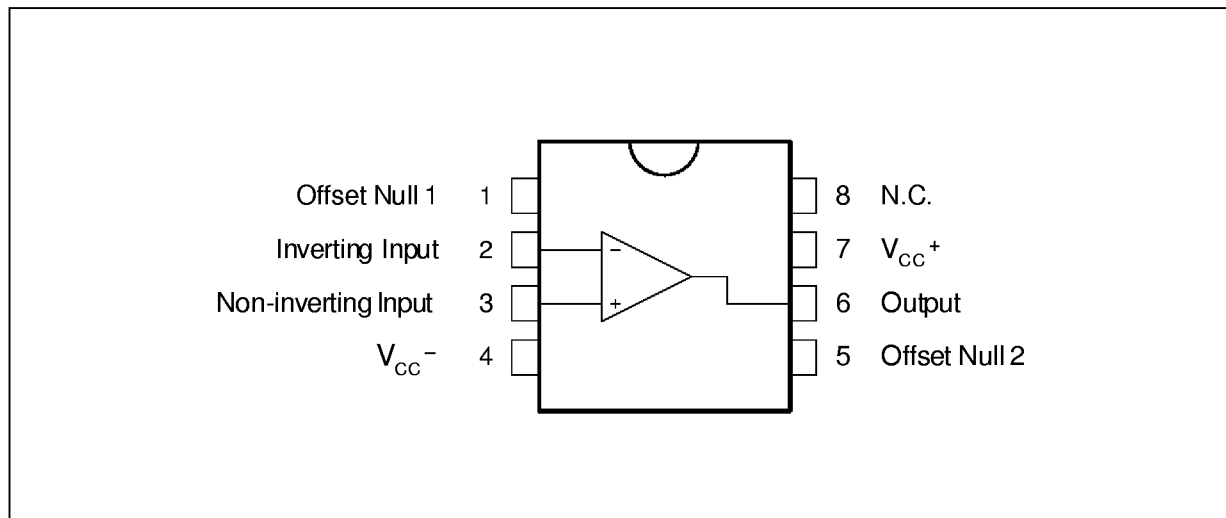

SCHEMATIC DIAGRAM

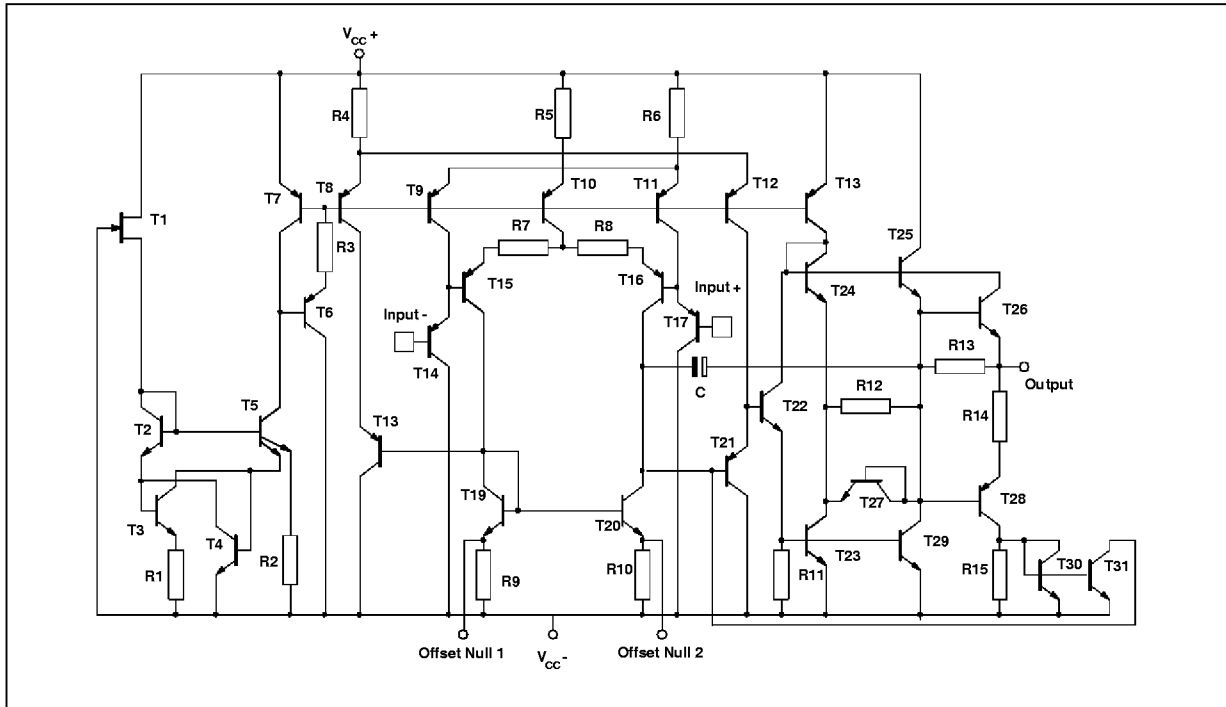

INPUT OFFSET VOLTAGE NULL CIRCUIT

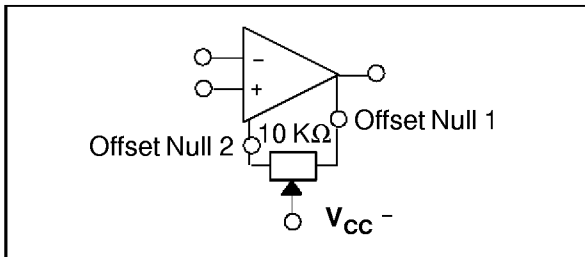

ABSOLUTE MAXIMUM RATINGS

Symbol	Parameter	Value	Unit	
V_{CC}	Supply Voltage	± 22	V	
V_{id}	Differential Input Voltage	(Note 1)	V	
V_i	Input Voltage	(Note 1)	V	
	Output Short Circuit Duration	Indefinite	s	
T_{oper}	Operating Temperature Range	MC33171 MC35171	-40 to 105 -55 to 125	$^{\circ}C$
T_j	Junction Temperature	150	$^{\circ}C$	
T_{stg}	Storage Temperature	-65 to 150	$^{\circ}C$	

Note 1: Either or both input voltages must not exceed the magnitude of V_{CC} .

OPERATING CONDITIONS

Symbol	Parameter	Value	Unit
V_{CC}	Supply Voltage Range	± 2 to ± 22	V

ELECTRICAL CHARACTERISTICS
 $V_{CC}^+ = +15V$, $V_{CC}^- = -15V$, R_L connected to Ground, $T_{amb} = 25^\circ C$ (unless otherwise specified)

Symbol	Parameter	Min.	Typ.	Max.	Unit
V_{io}	Input Offset Voltage $V_{CC}^+ = +15V$, $V_{CC}^- = -15V$, $V_{ic} = 0V$ $V_{CC}^+ = 5V$, $V_{CC}^- = 0V$, $V_{ic} = 0V$, $V_o = 1.4V$ $V_{CC}^+ = +15V$, $V_{CC}^- = -15V$, $V_{ic} = 0V$, $T_{min.} \leq T_{amb} \leq T_{max.}$		1 1	4.5 5 6.5	mV
DV_{io}	Input Offset Voltage Drift		10		$\mu V/^\circ C$
I_{io}	Input Offset Current ($V_{ic} = 0V$) $T_{min.} \leq T_{amb} \leq T_{max.}$		5	20 40	nA
I_{ib}	Input Bias Current ($V_{ic} = 0V$) $T_{min.} \leq T_{amb} \leq T_{max.}$		20	100 200	nA
A_{vd}	Large Signal Voltage Gain ($R_L = 10k\Omega$, $V_o = \pm 10V$) $T_{min.} \leq T_{amb} \leq T_{max.}$	50 25	100		V/mV
V_{OH}	High Level Output Voltage $V_{CC}^+ = 5V$, $V_{CC}^- = 0V$, $R_L = 10k\Omega$ $V_{CC}^+ = +15V$, $V_{CC}^- = -15V$, $R_L = 10k\Omega$ $V_{CC}^+ = +15V$, $V_{CC}^- = -15V$, $R_L = 10k\Omega$, $T_{min.} \leq T_{amb} \leq T_{max.}$	3.5 13.6 13.3	4.2 14.2		V
V_{OL}	Low Level Output Voltage $V_{CC}^+ = 5V$, $V_{CC}^- = 0V$, $R_L = 10k\Omega$ $V_{CC}^+ = +15V$, $V_{CC}^- = -15V$, $R_L = 10k\Omega$ $V_{CC}^+ = +15V$, $V_{CC}^- = -15V$, $R_L = 10k\Omega$, $T_{min.} \leq T_{amb} \leq T_{max.}$		0.1 -14	0.15 -13.6 -13.3	V
I_{sc}	Output Short Circuit Current ($V_{id} = \pm 1V$, $V_o = 0V$) Source Sink	3 15	6 27		mA
V_{icm}	Input Common Mode Voltage Range $T_{min.} \leq T_{amb} \leq T_{max.}$	V_{CC}^- to ($V_{CC}^+ - 1.8$) V_{CC}^- to ($V_{CC}^+ - 2.2$)			V
CMR	Common Mode Rejection Ratio ($V_i = V_{icm min.}$)	80	100		dB
SVR	Supply Voltage Rejection Ratio ($V_{CC} = \pm 5$ to $\pm 15V$)	80	100		dB
I_{CC}	Supply Current $V_{CC}^+ = 5V$, $V_{CC}^- = 0V$, no load $V_{CC}^+ = +15V$, $V_{CC}^- = -15V$, no load $V_{CC}^+ = +15V$, $V_{CC}^- = -15V$, no load, $T_{min.} \leq T_{amb} \leq T_{max.}$		200 220	250 250 300	μA
SR	Slew Rate ($V_i = \pm 10V$, $R_L = 10k\Omega$, $C_L = 100pF$)	1.6	2		V/ μs
GBP	Gain Bandwidth Product ($R_L = 10k\Omega$, $C_L = 100pF$, $f = 100kHz$)	1.4	2.1		MHz
ϕ_m	Phase Margin ($R_L = 10k\Omega$, $C_L = 100pF$)		45		Degrees
e_n	Equivalent Input Noise Voltage ($f = 1kHz$)		29		$\frac{nV}{\sqrt{Hz}}$
THD	Total Harmonic Distortion		0.05		%

PACKAGE MECHANICAL DATA
8 PINS - PLASTIC DIP

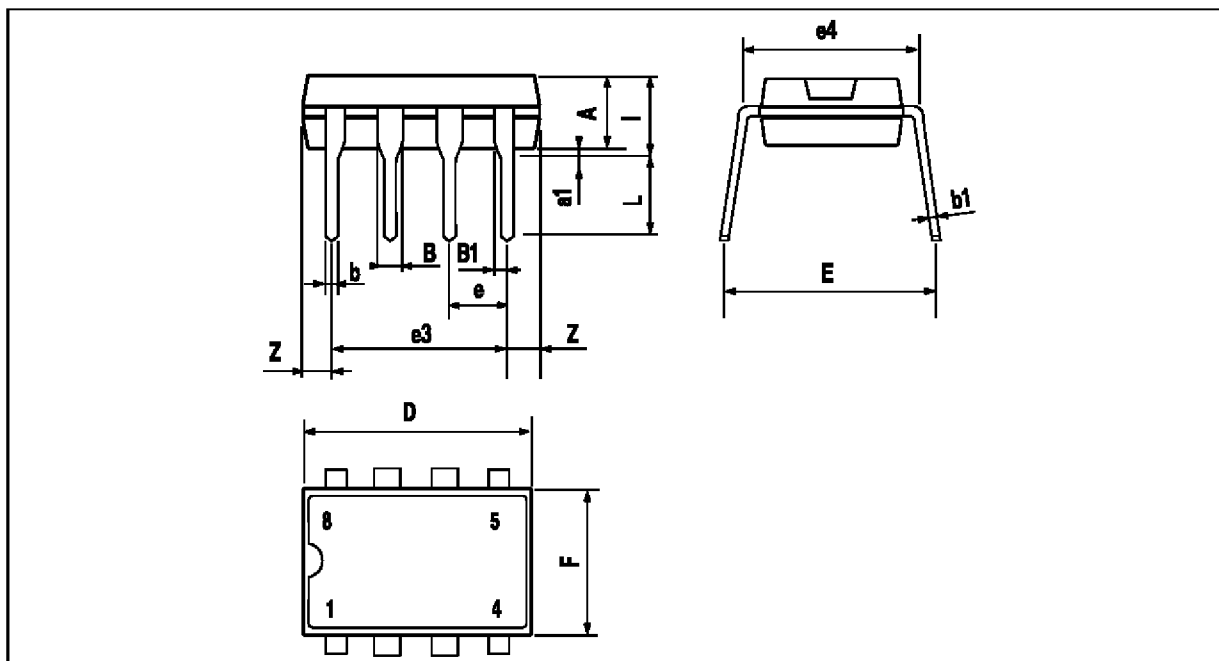

PM-DIP8.EPS

Dimensions	Millimeters			Inches		
	Min.	Typ.	Max.	Min.	Typ.	Max.
A		3.32			0.131	
a1	0.51			0.020		
B	1.15		1.65	0.045		0.065
b	0.356		0.55	0.014		0.022
b1	0.204		0.304	0.008		0.012
D			10.92			0.430
E	7.95		9.75	0.313		0.384
e		2.54			0.100	
e3		7.62			0.300	
e4		7.62			0.300	
F			6.6			0.260
i			5.08			0.200
L	3.18		3.81	0.125		0.150
Z			1.52			0.060

DIP8.TBL

PACKAGE MECHANICAL DATA
8 PINS - PLASTIC MICROPACKAGE (SO)

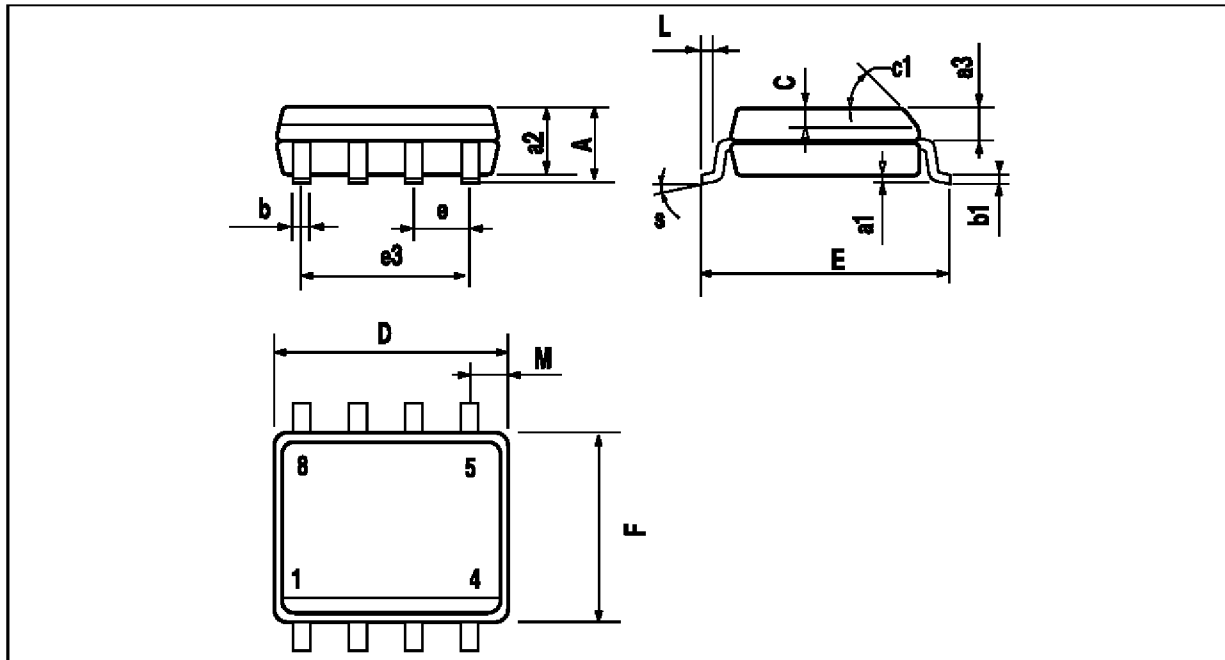

PM-S08.EPS

Dimensions	Millimeters			Inches		
	Min.	Typ.	Max.	Min.	Typ.	Max.
A			1.75			0.069
a1	0.1		0.25	0.004		0.010
a2			1.65			0.065
a3	0.65		0.85	0.026		0.033
b	0.35		0.48	0.014		0.019
b1	0.19		0.25	0.007		0.010
C	0.25		0.5	0.010		0.020
c1	45° (typ.)					
D	4.8		5.0	0.189		0.197
E	5.8		6.2	0.228		0.244
e		1.27			0.050	
e3		3.81			0.150	
F	3.8		4.0	0.150		0.157
L	0.4		1.27	0.016		0.050
M			0.6			0.024
S	8° (max.)					

S08.TBL

Information furnished is believed to be accurate and reliable. However, SGS-THOMSON Microelectronics assumes no responsibility for the consequences of use of such information nor for any infringement of patents or other rights of third parties which may result from its use. No license is granted by implication or otherwise under any patent or patent rights of SGS-THOMSON Microelectronics. Specifications mentioned in this publication are subject to change without notice. This publication supersedes and replaces all information previously supplied. SGS-THOMSON Microelectronics products are not authorized for use as critical components in life support devices or systems without express written approval of SGS-THOMSON Microelectronics.

© 1997 SGS-THOMSON Microelectronics – Printed in Italy – All Rights Reserved

SGS-THOMSON Microelectronics GROUP OF COMPANIES
 Australia - Brazil - Canada - China - France - Germany - Italy - Japan - Korea - Malaysia - Malta - Morocco
 The Netherlands - Singapore - Spain - Sweden - Switzerland - Taiwan - Thailand - United Kingdom - U.S.A.

ORDER CODE :