

100 V, precision, bidirectional current sense amplifier

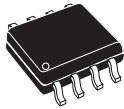

SO8



MiniSO8

[Maturity status link](#)[TSC2020](#)

Features

- Wide common-mode voltage: -4 to 100 V
- High common-mode rejection CMR: 100 dB min.
- Offset voltage: $\pm 150 \mu\text{V}$ max.
- Offset drift: $0.5 \mu\text{V}/^\circ\text{C}$ max.
- Enhanced PWM rejection
- 2.7 to 5.5 V supply voltage
- Internal fixed gain 20 V/V
- Gain error: 0.3% max.
- Gain drift: $3.5 \text{ ppm}/^\circ\text{C}$ max.
- SO8 and MiniSO8 package
- AEC-Q100 qualified

Applications

- High-side/low-side current sensing
- Battery management system
- 48 V power distribution
- 48 V power tools
- Motor control
- Automotive

Description

TSC2020 is a precision bidirectional current sense amplifier. It can sense current via a shunt resistor over a wide range of common-mode voltages, from -4 to +100 V, whatever the supply voltage is. It is able to sense very low drop voltages, minimizing measurement error.

TSC2020 is a current sense amplifier that may be used for various functions like precision current measurement, overcurrent protection, current monitoring, and feedback loops. This device fully operates over the supply voltage range of 2.7 to 5.5 V, and over the industrial temperature range of -40 to 125 °C.

1 Block diagram and pin description

Figure 1. Block diagram

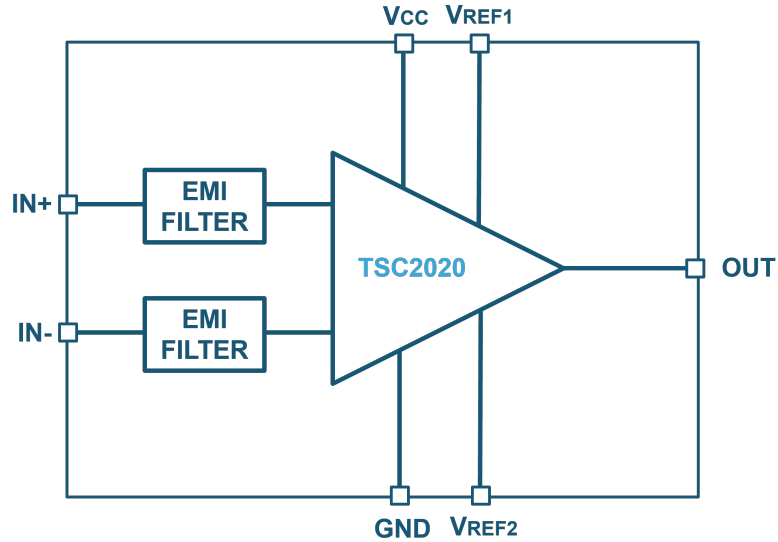

Figure 2. Pin connections (top view)

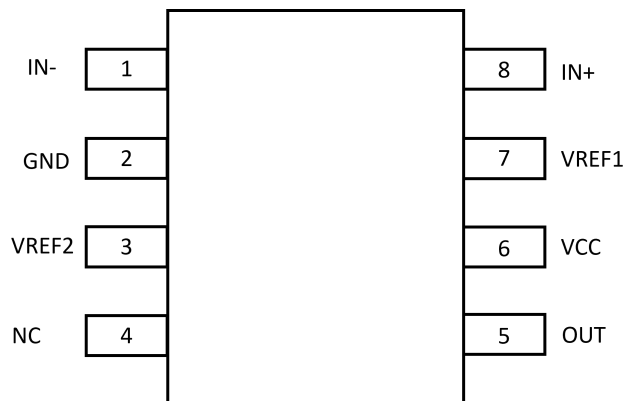

Table 1. Pin description

Pin	Pin name	Description
1	IN-	Negative input
2	GND	Ground
3	VREF2	Reference voltage 2
4	NC	Not connected
5	OUT	Output
6	VCC	Supply voltage
7	VREF1	Reference voltage 1
8	IN+	Positive input

2 Absolute maximum ratings and operation conditions

Table 2. Absolute maximum ratings

Symbol	Parameter	Value	Unit
V_{CC}	Supply voltage ⁽¹⁾	-0.3 to 5.8	V
V_{ICM}	Common-mode voltage on input pins	-5 to 105	V
V_{DIF}	Differential voltage between input pins (IN+, IN-)	±70	V
V_{REF1} , V_{REF2} , V_{OUT}	Voltage present on pins REF1, REF2, and OUT	GND - 0.3 to $V_{CC} + 0.3$	V
I_{IN}	Input current on V_{IN+} , V_{IN-} ⁽²⁾	1.5	mA
T_J	Junction temperature	150	°C
T_{STG}	Storage temperature	-65 to 150	°C
ESD	Human body model (HBM) ⁽³⁾	2000	V
	Charged device model (CDM) ⁽⁴⁾		
	SO8	750	V
	MiniSO8	1000	
R_{THJA}	Thermal resistance junction to ambient ⁽⁵⁾⁽⁶⁾		
	SO8	125	°C/W
	MiniSO8	190	

1. All voltage values, except the differential voltage, are with respect to the network ground terminal.
2. Input voltage can go beyond the supply voltage, but input current must be limited. Using a serial resistor with the input is highly recommended in that case.
3. According to JEDEC standard JESD22-A114F.
4. According to ANSI/ESD STM 5.3.1.
5. Short-circuits can cause excessive heating and destructive dissipation.
6. The RTHs are typical values.

Table 3. Operating conditions

Symbol	Parameter	Value	Unit
V_{CC}	Supply voltage	2.7 to 5.5	V
V_{ICM}	Common-mode voltage on input pins	-4 to +100	V
V_{REF}	Output offset adjustment range	0 to V_{CC}	V
T	Operating free-air temperature range	-40 to 125	°C

3 Electrical characteristics

Table 4. Electrical characteristics - $V_{CC} = 2.7\text{ V}$, $V_{ICM} = 48\text{ V}$, $T = 25\text{ °C}$ (unless otherwise specified).

Symbol	Parameter	Conditions	Min.	Typ.	Max.	Unit
Power supply						
I_{CC}	Current consumption	$V_{ICM} = -4\text{ to }100\text{ V}$ $T_{min} < T < T_{max}$		1.7	2.3 2.3	mA
Input						
$ V_{os} $	Offset voltage (RTI) ⁽¹⁾	$V_{ICM} = 12\text{ V}$, $V_{REF} = 1.35\text{ V}$ $T_{min} < T < T_{max}$			150 200	μV
		$V_{ICM} = 48\text{ V}$, $V_{REF} = 1.35\text{ V}$ $T_{min} < T < T_{max}$			400 500	
$ \Delta V_{os}/\Delta T $	Offset drift vs. temperature	$V_{ICM} = 12\text{ V}$, $T_{min} < T < T_{max}$			0.5	$\mu\text{V}/\text{°C}$
		$V_{ICM} = 48\text{ V}$, $T_{min} < T < T_{max}$			1	
CMR	Common-mode rejection	$V_{ICM} = -4\text{ to }100\text{ V}$, DC mode $T_{min} < T < T_{max}$	100 100	112		dB
I_{IB}	Input bias current	$V_{ICM} = 12\text{ V}$, $V_{sense} = 0$ $T_{min} < T < T_{max}$		100	130 140	μA
		$V_{ICM} = 48\text{ V}$, $V_{sense} = 0$ $T_{min} < T < T_{max}$		200	230 240	
$ V_{sense} $	V_{sense} operating range with $E_g \leq 0.3\%$ ⁽²⁾	TSC2020 $T_{min} < T < T_{max}$			123.8 123.6	mV
Output						
G	Gain			20		V/V
E_g	Gain error	$\Delta V_{OUT} = 100\text{ mV to } (V_{CC} - 100\text{ mV})$ $T_{min} < T < T_{max}$		0.01	0.3 0.35	%
$\Delta E_g/\Delta T$	Gain error drift	$T_{min} < T < T_{max}$			3.5	ppm/°C
NLE	Linearity error	$V_{ICM} = -4\text{ to }100\text{ V}$		0.01		%
$V_{CC} - V_{OH}$	Drop voltage output high	$I_{source} = 0.2\text{ mA}$ $T_{min} < T < T_{max}$		11	25 35	mV
		$I_{source} = 2\text{ mA}$ $T_{min} < T < T_{max}$		115	150 200	
V_{OL}	Output voltage low	$I_{sink} = 0.2\text{ mA}$ $T_{min} < T < T_{max}$		24	40 55	mV
		$I_{sink} = 2\text{ mA}$ $T_{min} < T < T_{max}$		200	240 390	
I_{OUT}	Output current	Sink mode $T_{min} < T < T_{max}$	8 5	12.5	18 24	mA
		Source mode $T_{min} < T < T_{max}$	10 5	14.5	25 30	
Reg Load	Load regulation	$I_{OUT} = -5\text{ to }+5\text{ mA}$		0.2	1.5	$\frac{mV}{mA}$
C_L	Maximum capacitive load	No sustained oscillation		1		nF

Symbol	Parameter	Conditions	Min.	Typ.	Max.	Unit
Offset adjustment						
R _T	V _{REF} gain	Voltage applied on one V _{REF} pin		0.5		V/V
Acc	V _{REF} gain error	One V _{REF} pin connected to V _{CC} the other to GND		0.2		%
Dynamic performances						
BW	Small signal -3 dB bandwidth	R _L = 10 kΩ, C _L = 100 pF	350	650		kHz
		T _{min} < T < T _{max}	350			
SR	Slew rate	C _L = 100 pF, V _{ICM} = 1 V	1.1	1.8		V/μs
		T _{min} < T < T _{max}	1			
E _N	Spectral density (RTI) ⁽¹⁾	f = 1 kHz		63		nV/√Hz

1. RTI stands for "Related to input."

2. V_{sense} = (V_{in+}) – (V_{in-}).

Table 5. Electrical characteristics - $V_{CC} = 5\text{ V}$, $V_{ICM} = 48\text{ V}$, $T = 25\text{ °C}$ (unless otherwise specified).

Symbol	Parameter	Conditions	Min.	Typ.	Max.	Unit
Power supply						
I_{CC}	Current consumption	$V_{ICM} = -4\text{ to }100\text{ V}$ $T_{min} < T < T_{max}$		1.8	2.4 2.4	mA
Input						
$ V_{os} $	Offset voltage (RTI) ⁽¹⁾	$V_{ICM} = 12\text{ V}$, $V_{REF} = 2.5\text{ V}$ $T_{min} < T < T_{max}$			150 200	μV
		$V_{ICM} = 48\text{ V}$, $V_{REF} = 2.5\text{ V}$ $T_{min} < T < T_{max}$			400 500	
$ \Delta V_{os}/\Delta T $	Offset drift vs. temperature	$V_{ICM} = 12\text{ V}$, $T_{min} < T < T_{max}$			0.5	$\mu\text{V}/\text{°C}$
		$V_{ICM} = 48\text{ V}$, $T_{min} < T < T_{max}$			1	
CMR	Common-mode rejection	$V_{ICM} = -4\text{ to }100\text{ V}$, DC mode $T_{min} < T < T_{max}$	100 100	112		dB
SVR	Supply voltage rejection	$V_{CC} = 2.7\text{ to }5.5\text{ V}$ $T_{min} < T < T_{max}$	100 100	118		dB
I_{IB}	Input bias current	$V_{ICM} = 12\text{ V}$, $V_{sense} = 0$ $T_{min} < T < T_{max}$		100	130 140	μA
		$V_{ICM} = 48\text{ V}$, $V_{sense} = 0$ $T_{min} < T < T_{max}$		200	230 240	
V_{sense}	V_{sense} operating range with $E_g \leq 0.3\%$ ⁽²⁾	TSC2020 $T_{min} < T < T_{max}$			238.5 238.2	mV
Output						
G	Gain			20		V/V
E_g	Gain error	$\Delta V_{OUT} = 100\text{ mV to } (V_{CC} - 100\text{ mV})$ $T_{min} < T < T_{max}$		0.01	0.3 0.35	%
$\Delta E_g/\Delta T$	Gain error drift	$T_{min} < T < T_{max}$			3.5	ppm/°C
NLE	Linearity error	$V_{ICM} = -4\text{ to }100\text{ V}$		0.01		%
$V_{CC} - V_{OH}$	Drop voltage output	$I_{source} = 0.2\text{ mA}$ $T_{min} < T < T_{max}$		18	35 45	mV
		$I_{source} = 2\text{ mA}$ $T_{min} < T < T_{max}$		122	155 210	
V_{OL}	Output voltage low	$I_{sink} = 0.2\text{ mA}$ $T_{min} < T < T_{max}$		35	50 70	
		$I_{sink} = 2\text{ mA}$ $T_{min} < T < T_{max}$		217	250 400	
I_{OUT}	Output current	Sink mode $T_{min} < T < T_{max}$	8 5	13.5	20 24	mA
		Source mode $T_{min} < T < T_{max}$	10 5	14.5	25 30	

Symbol	Parameter	Conditions	Min.	Typ.	Max.	Unit
Reg load	Load regulation	$I_{OUT} = -5$ to $+5$ mA		0.2	1.5	$\frac{mV}{mA}$
Offset adjustment						
RT	V_{REF} gain	Voltage applied on one V_{REF} pin		0.5		V/V
Acc	V_{REF} gain error	One V_{REF} pin connected to V_{CC} the other to GND		0.2		%
Dynamic performances						
BW	Small signal -3 dB bandwidth	$R_L = 10$ k Ω , $C_L = 100$ pF	450	700		kHz
		$T_{min} < T < T_{max}$	450			
SR	Slew rate	$C_L = 100$ pF, $V_{ICM} = 1$ V	1.4	2		V/ μ s
		$T_{min} < T < T_{max}$	1.2			
EN	Spectral density (RTI) ⁽¹⁾	$f = 1$ kHz		53		nV/ \sqrt{Hz}

1. RTI stands for "Related to input."

2. $V_{sense} = (V_{in+}) - (V_{in-})$.

4 Typical characteristics

TSC2020 is used for typical characteristics, unless otherwise specified.

Figure 3. Input offset production distribution

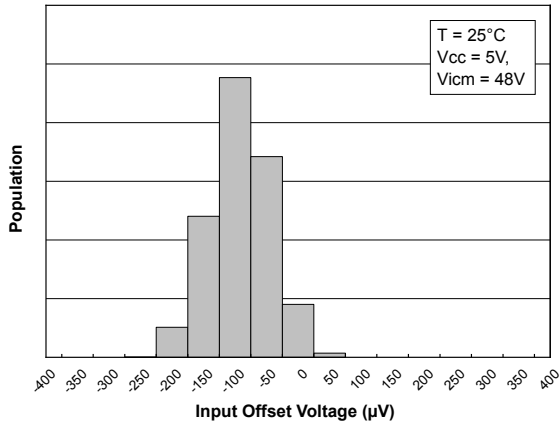

Figure 4. Gain error production distribution

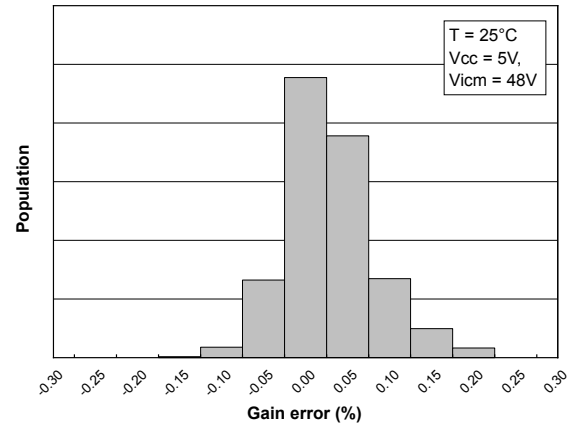

Figure 5. Common-mode rejection ratio production distribution

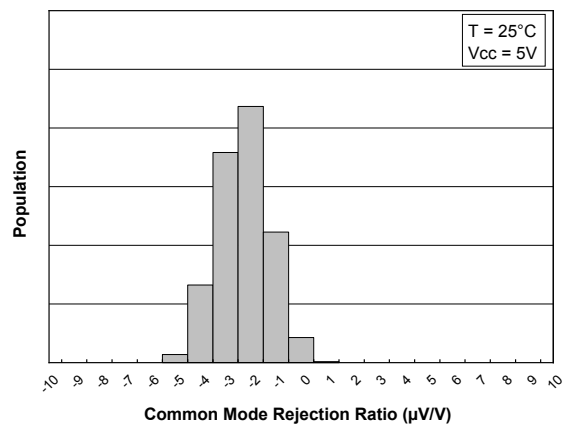

Figure 6. Supply current vs. supply voltage

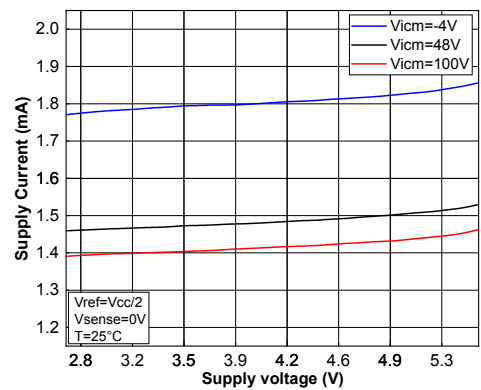

Figure 7. Supply current vs. input common-mode

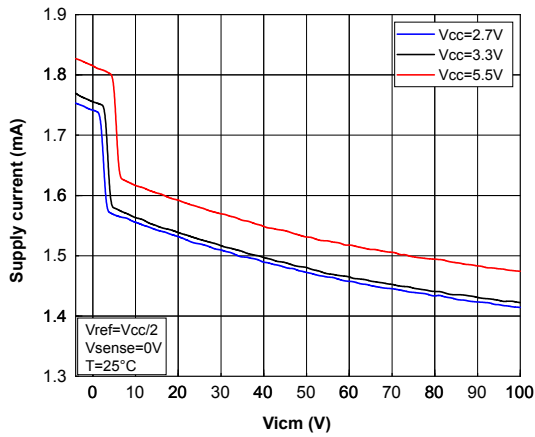

Figure 8. Supply current vs. temperature

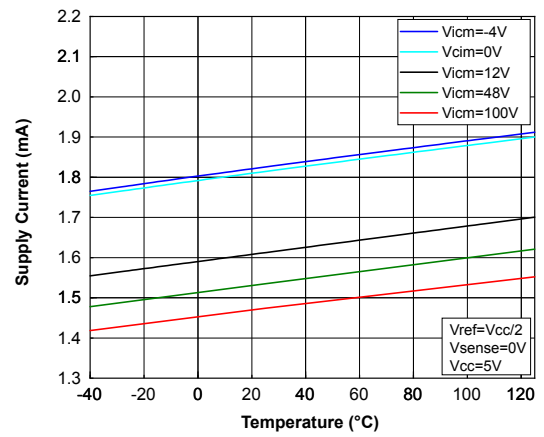

Figure 9. Input bias current vs. input common-mode

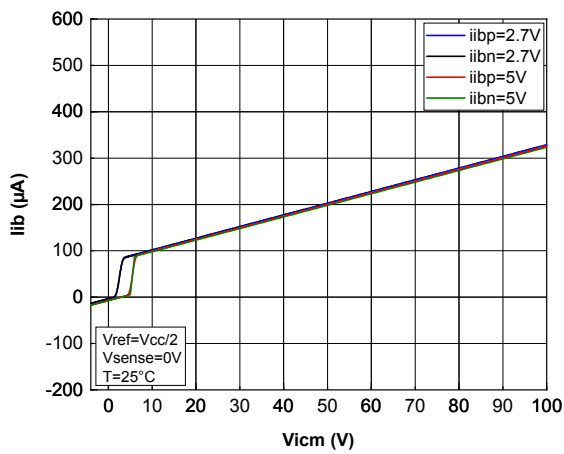

Figure 10. Input bias current vs. temperature

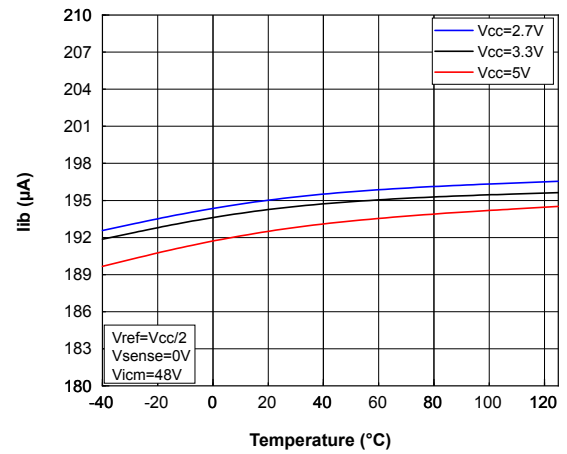

Figure 11. Input bias current vs. temperature $V_{CC} = 0\text{ V}$

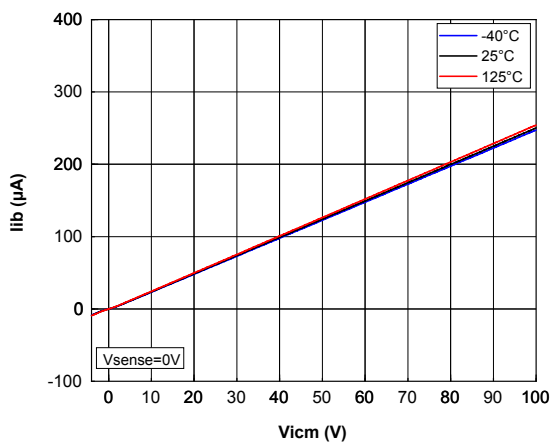

Figure 12. Input bias current vs. Vsense

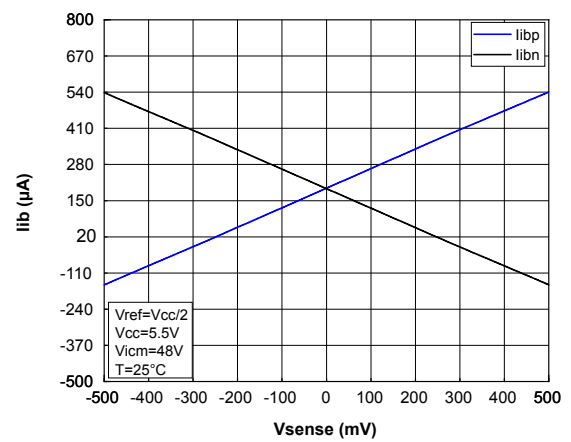

Figure 13. Input offset voltage vs. temperature

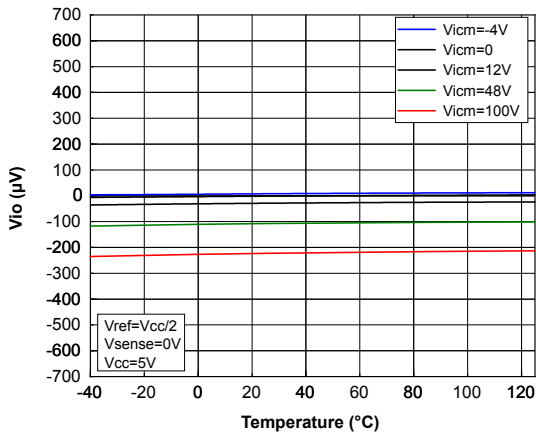

Figure 14. Input offset voltage vs. input common-mode with $V_{CC} = 2.7 V$

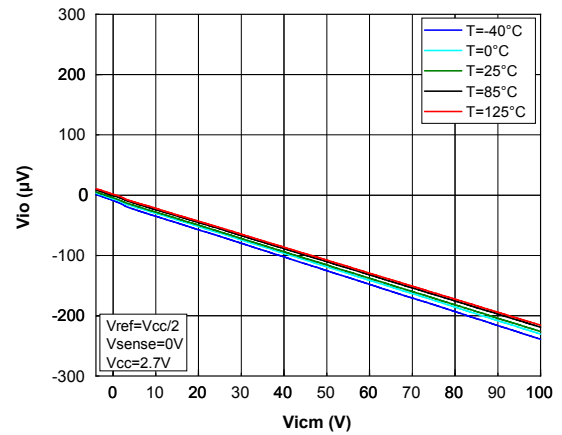

Figure 15. Input offset voltage vs. input common-mode with $V_{CC} = 5.5 V$

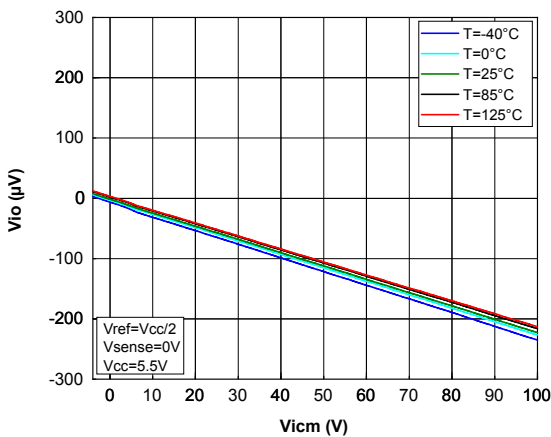

Figure 16. Input offset voltage vs. supply voltage

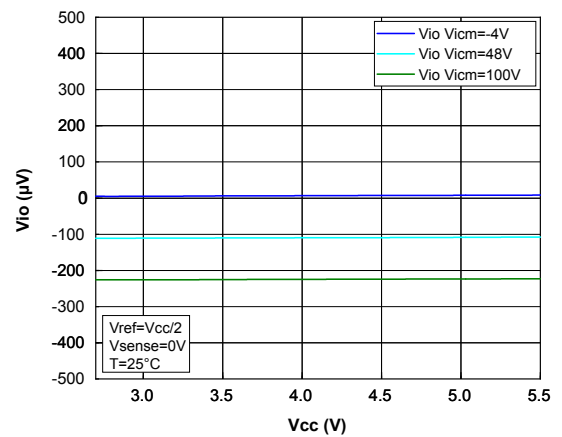

Figure 17. Output current vs. output voltage

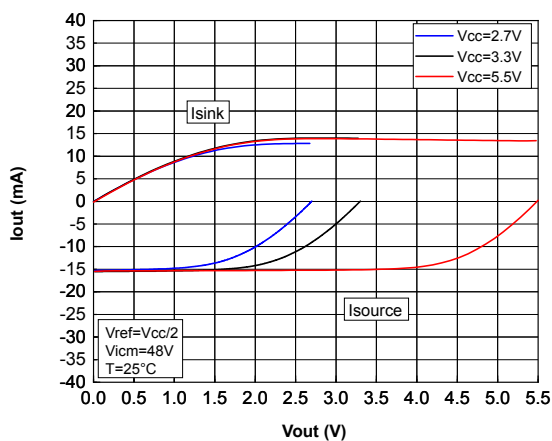

Figure 18. Output current vs. temperature with $V_{CC} = 5.5 V$

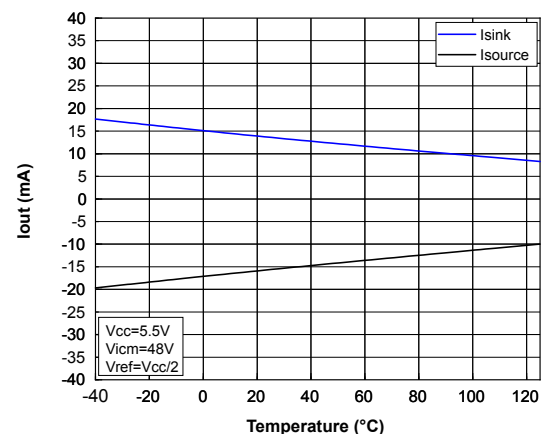

Figure 19. Output current vs. temperature with $V_{CC} = 2.7\text{ V}$

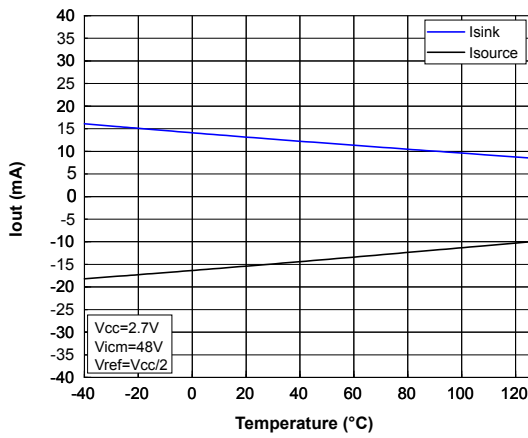

Figure 20. V_{OH} and V_{OL} vs. input common-mode voltage with $V_{CC} = 5.5\text{ V}$

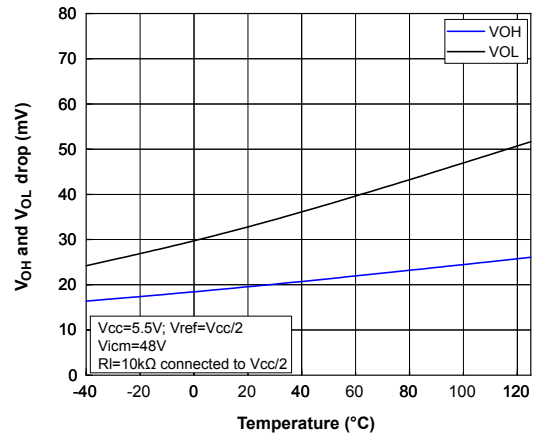

Figure 21. V_{OH} and V_{OL} vs. input common-mode voltage with $V_{CC} = 2.7\text{ V}$

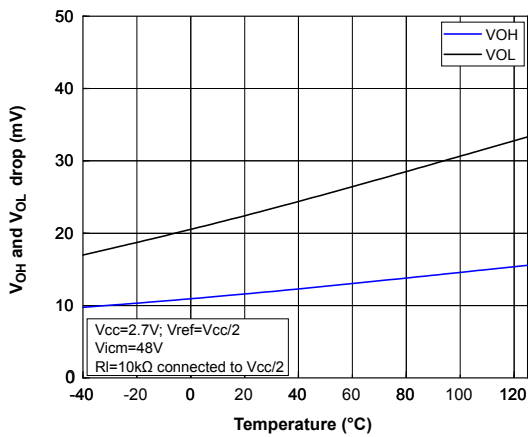

Figure 22. Linearity vs. Vense with $V_{CC} = 5.5\text{ V}$

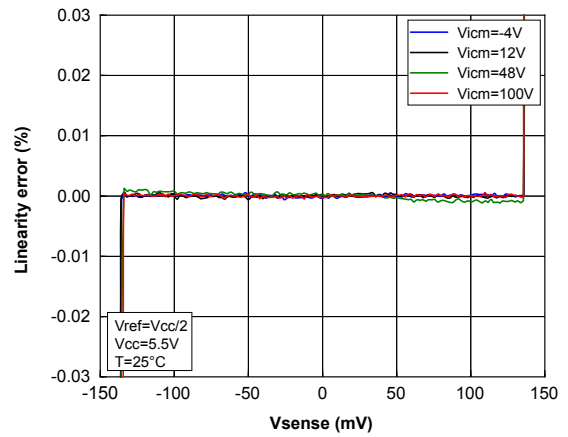

Figure 23. Linearity vs. Vense and temperature

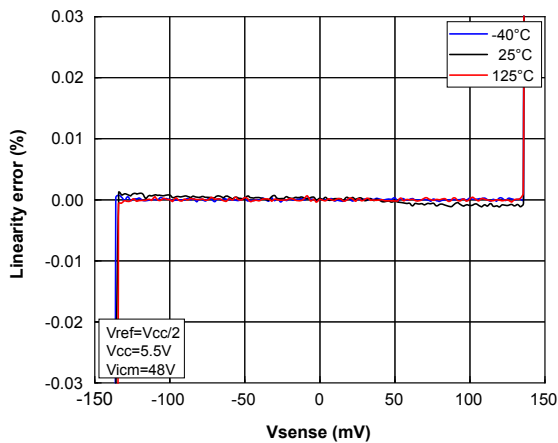

Figure 24. Gain error vs. input common-mode

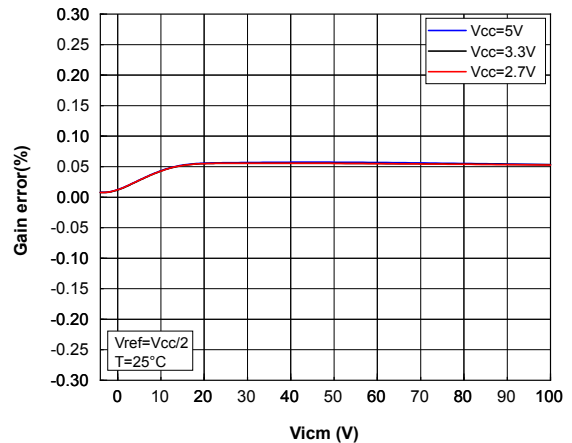

Figure 25. Gain error vs. temperature

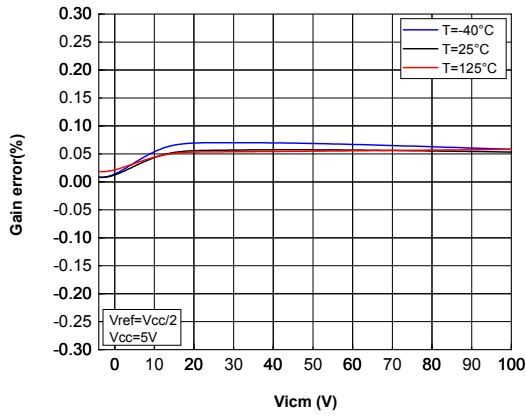

Figure 26. Load regulation with $V_{CC} = 5\text{ V}$

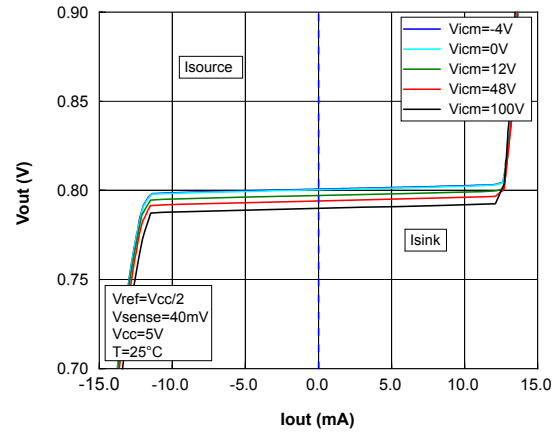

Figure 27. Gain vs. frequency

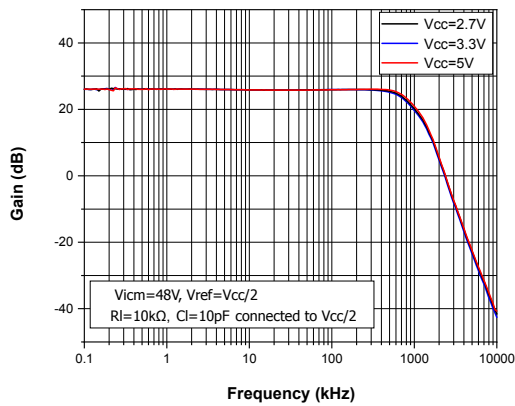

Figure 28. Gain vs. frequency different capacitive load

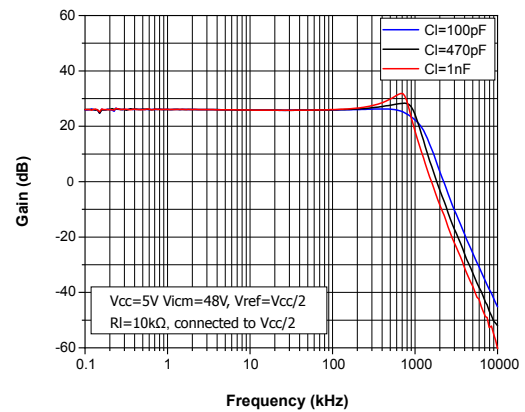

Figure 29. Bandwidth vs. input common-mode

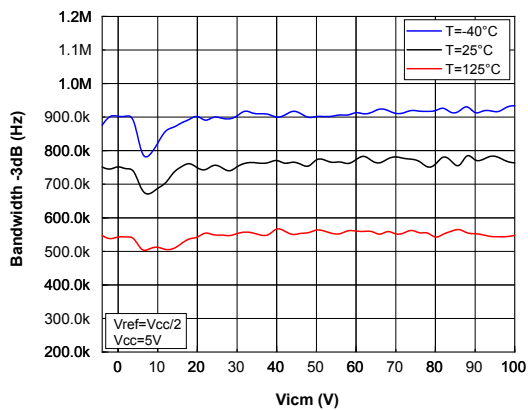

Figure 30. Overshoot vs. capacitive load

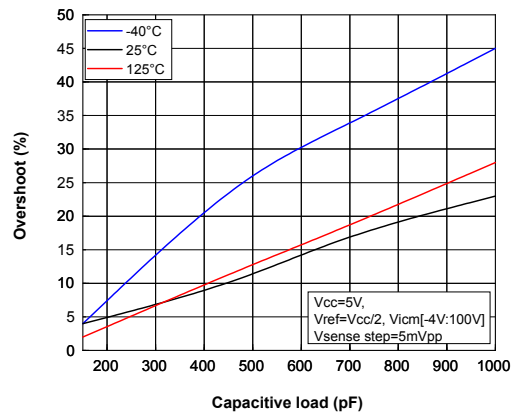

Figure 31. Small signal response with $V_{CC} = 5\text{ V}$

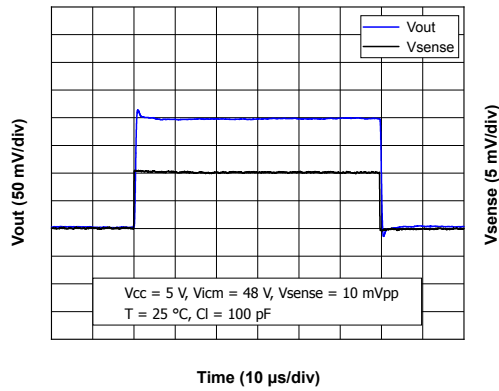

Figure 32. Large signal response with $V_{CC} = 5\text{ V}$

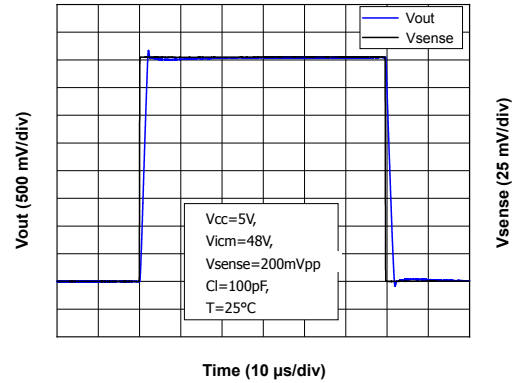

Figure 33. Positive settling time 1%

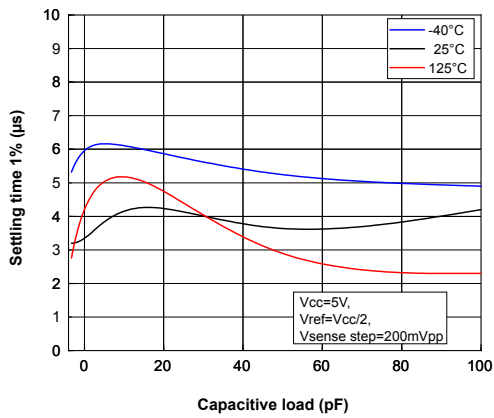

Figure 34. Negative settling time 1%

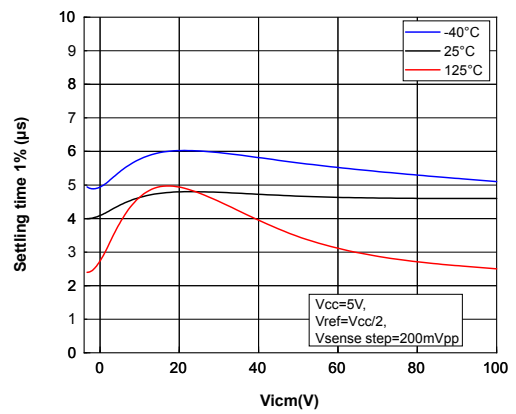

Figure 35. 48 V common-mode positive step response recovery

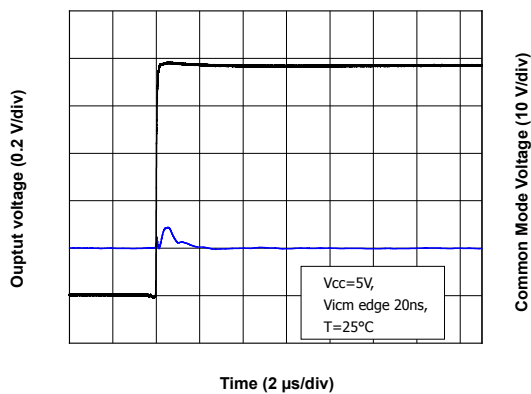

Figure 36. 48 V common-mode negative step response recovery

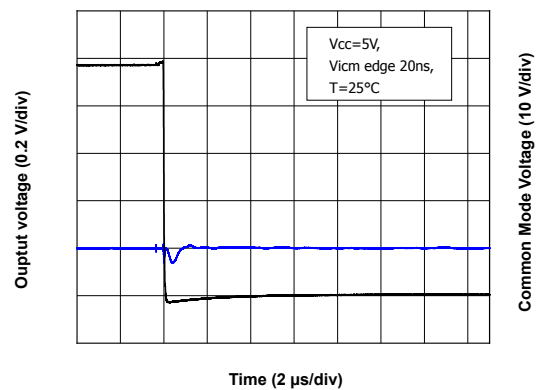

Figure 37. 100 V common-mode positive step response recovery

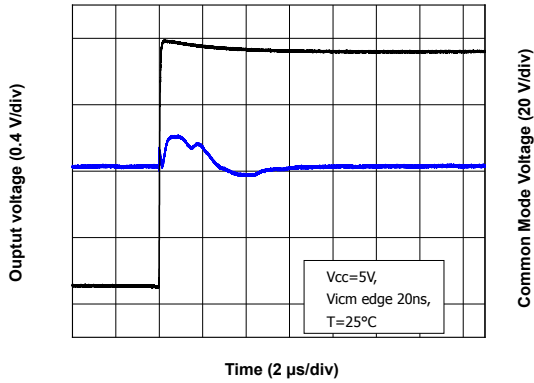

Figure 38. 100 V common-mode negative step response recovery

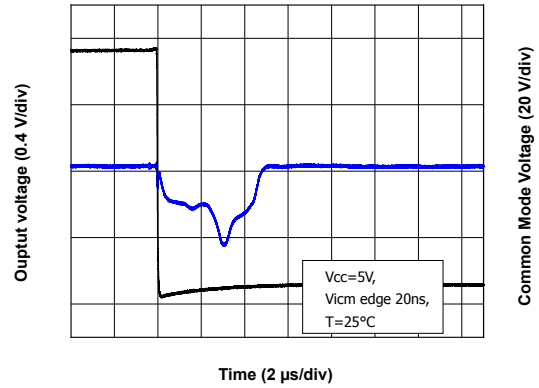

Figure 39. PSRR vs. frequency

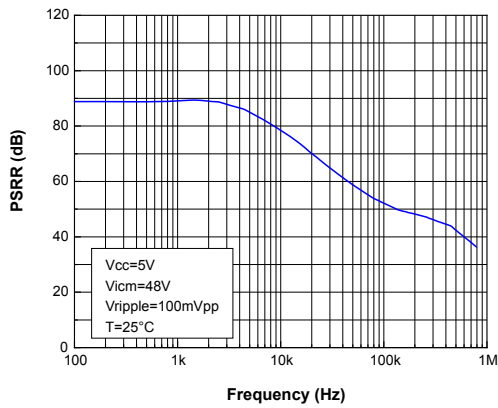

Figure 40. CMRR vs. frequency

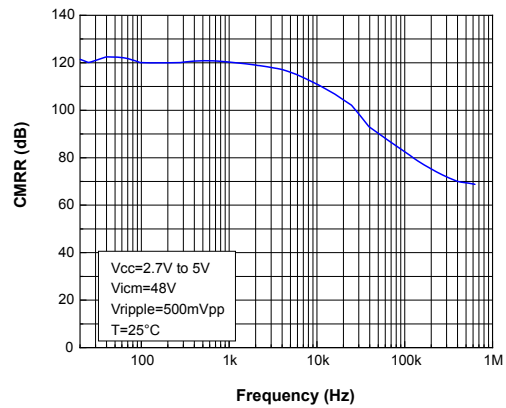

Figure 41. Positive overvoltage recovery

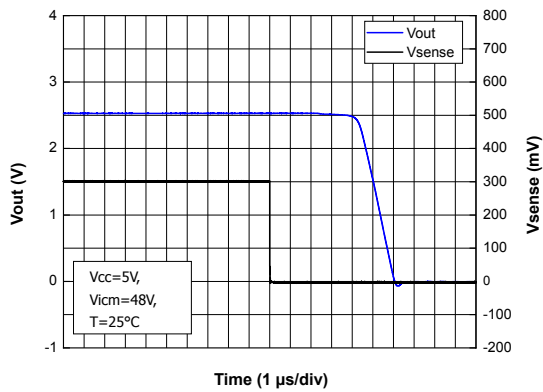

Figure 42. Negative overvoltage recovery

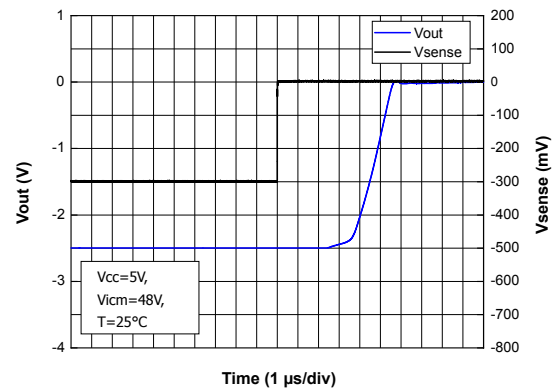

Figure 43. Overvoltage recovery vs. V_{icm} , $V_{CC} = 5\text{ V}$

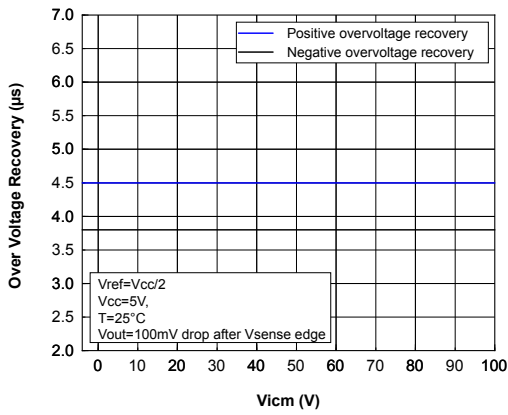

Figure 44. Noise vs. frequency

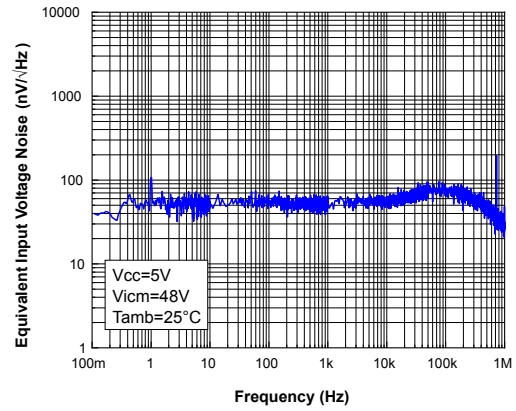

Figure 45. 0.1 Hz to 10 Hz voltage noise

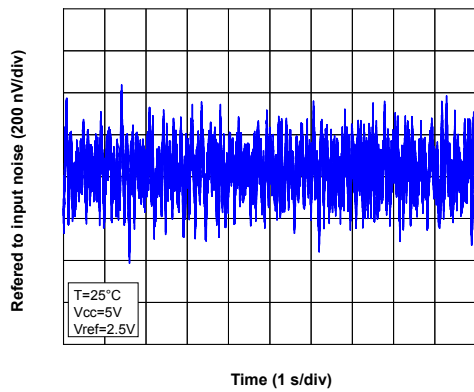

Figure 46. Power up time delay

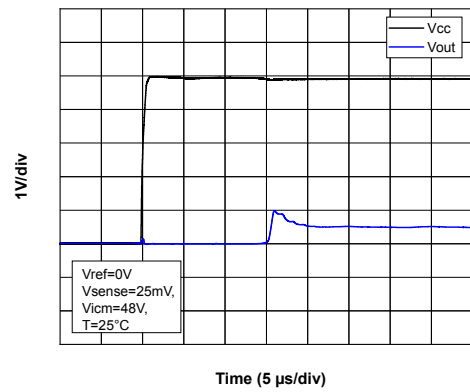
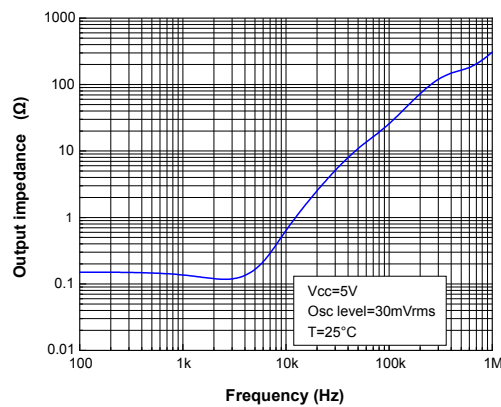

Figure 47. Output impedance vs. frequency



5 **Package information**

In order to meet environmental requirements, ST offers these devices in different grades of **ECOPACK** packages, depending on their level of environmental compliance. ECOPACK specifications, grade definitions and product status are available at: www.st.com. ECOPACK is an ST trademark.

5.1 SO8 package information

Figure 48. SO8 package outline

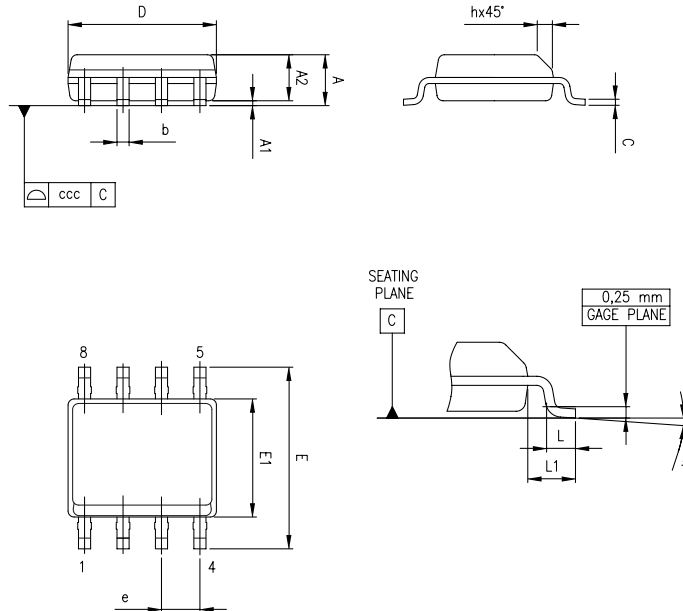
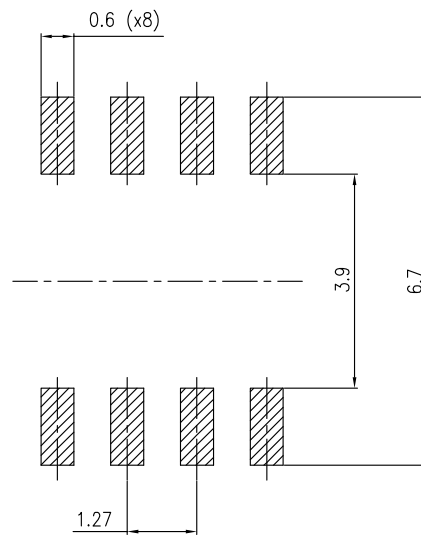

Table 6. SO8 package mechanical data

Ref.	Dimensions					
	Millimeters			Inches		
	Min.	Typ.	Max.	Min.	Typ.	Max.
A			1.75			0.069
A1	0.10		0.25	0.04		0.010
A2	1.25			0.049		
b	0.28	0.40	0.48	0.011	0.016	0.019
c	0.17		0.23	0.007		0.010
D	4.80	4.90	5.00	0.189	0.193	0.197
E	5.80	6.00	6.20	0.228	0.236	0.244
E1	3.80	3.90	4.00	0.150	0.154	0.157
e		1.27			0.050	
h	0.25		0.50	0.010		0.020
L	0.40	0.635	1.27	0.016		0.050
L1		1.04			0.040	
k	1°		8°	1°		8°
ccc			0.10			0.004

Figure 49. SO8 recommended footprint



5.2 MiniSO8 package information

Figure 50. MiniSO8 package outline

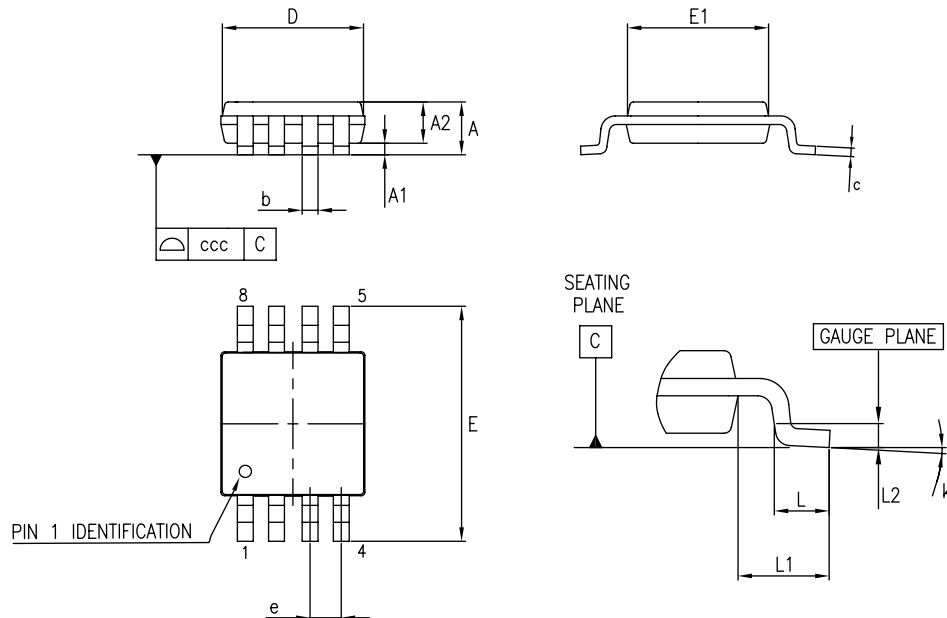
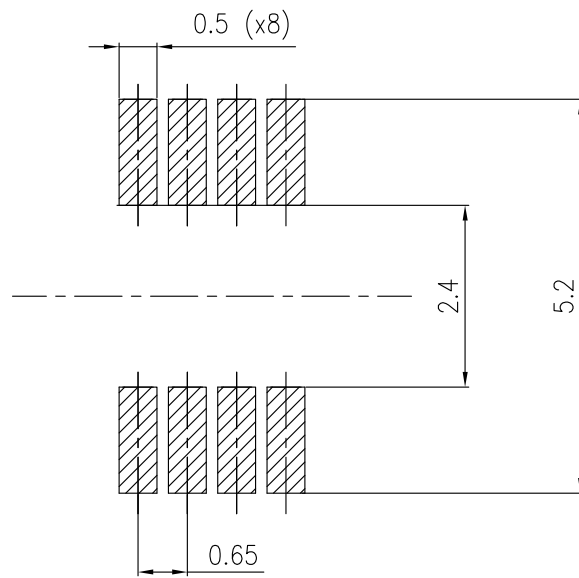

Table 7. MiniSO8 mechanical data

Ref.	Dimensions					
	Millimeters			Inches		
	Min.	Typ.	Max.	Min.	Typ.	Max.
A			1.1			0.043
A1	0		0.15	0		0.006
A2	0.75	0.85	0.95	0.03	0.033	0.037
b	0.22		0.4	0.009		0.016
c	0.08		0.23	0.003		0.009
D	2.8	3	3.2	0.11	0.118	0.126
E	4.65	4.9	5.15	0.183	0.193	0.203
E1	2.8	3	3.1	0.11	0.118	0.122
e		0.65			0.026	
L	0.4	0.6	0.8	0.016	0.024	0.031
L1		0.95			0.037	
L2		0.25			0.01	
k	0°		8°	0°		8°
ccc			0.1			0.004

Figure 51. MiniSO8 recommended footprint



6 Ordering information

Table 8. Order codes

Order code	Gain (V/V)	Package	Packaging	Marking
TSC2020IDT	20	SO8	Tape & Reel	TSC2020
TSC2020IYDT ⁽¹⁾				TSC2020Y
TSC2020IST		MiniSO8		O129
TSC2020IYST ⁽¹⁾				O132

1. Qualified and characterized according to AEC Q100 and Q003 or equivalent, advanced screening according to AEC Q001 & Q002 or equivalent.

Revision history

Table 9. Document revision history

Date	Revision	Changes
22-Sep-2023	1	Initial release.

Contents

1	Block diagram and pin description	2
2	Absolute maximum ratings and operation conditions	3
3	Electrical characteristics	4
4	Typical characteristics	8
5	Package information	16
5.1	SO8 package information	17
5.2	MiniSO8 package information	19
6	Ordering information	21
	Revision history	22

List of tables

Table 1.	Pin description	2
Table 2.	Absolute maximum ratings	3
Table 3.	Operating conditions	3
Table 4.	Electrical characteristics - $V_{CC} = 2.7\text{ V}$, $V_{ICM} = 48\text{ V}$, $T = 25\text{ }^{\circ}\text{C}$ (unless otherwise specified).	4
Table 5.	Electrical characteristics - $V_{CC} = 5\text{ V}$, $V_{ICM} = 48\text{ V}$, $T = 25\text{ }^{\circ}\text{C}$ (unless otherwise specified).	6
Table 6.	SO8 package mechanical data	17
Table 7.	MiniSO8 mechanical data	19
Table 8.	Order codes	21
Table 9.	Document revision history	22

List of figures

Figure 1.	Block diagram	2
Figure 2.	Pin connections (top view)	2
Figure 3.	Input offset production distribution	8
Figure 4.	Gain error production distribution	8
Figure 5.	Common-mode rejection ratio production distribution	8
Figure 6.	Supply current vs. supply voltage	8
Figure 7.	Supply current vs. input common-mode	9
Figure 8.	Supply current vs. temperature	9
Figure 9.	Input bias current vs. input common-mode	9
Figure 10.	Input bias current vs. temperature	9
Figure 11.	Input bias current vs. temperature $V_{CC} = 0\text{ V}$	9
Figure 12.	Input bias current vs. V_{sense}	9
Figure 13.	Input offset voltage vs. temperature	10
Figure 14.	Input offset voltage vs. input common-mode with $V_{CC} = 2.7\text{ V}$	10
Figure 15.	Input offset voltage vs. input common-mode with $V_{CC} = 5.5\text{ V}$	10
Figure 16.	Input offset voltage vs. supply voltage	10
Figure 17.	Output current vs. output voltage	10
Figure 18.	Output current vs. temperature with $V_{CC} = 5.5\text{ V}$	10
Figure 19.	Output current vs. temperature with $V_{CC} = 2.7\text{ V}$	11
Figure 20.	V_{oh} and V_{ol} vs. input common-mode voltage with $V_{CC} = 5.5\text{ V}$	11
Figure 21.	V_{oh} and V_{ol} vs. input common-mode voltage with $V_{CC} = 2.7\text{ V}$	11
Figure 22.	Linearity vs. V_{sense} with $V_{CC} = 5.5\text{ V}$	11
Figure 23.	Linearity vs. V_{sense} and temperature	11
Figure 24.	Gain error vs. input common-mode	11
Figure 25.	Gain error vs. temperature	12
Figure 26.	Load regulation with $V_{CC} = 5\text{ V}$	12
Figure 27.	Gain vs. frequency	12
Figure 28.	Gain vs. frequency different capacitive load	12
Figure 29.	Bandwidth vs. input common-mode	12
Figure 30.	Overshoot vs. capacitive load	12
Figure 31.	Small signal response with $V_{CC} = 5\text{ V}$	13
Figure 32.	Large signal response with $V_{CC} = 5\text{ V}$	13
Figure 33.	Positive settling time 1%	13
Figure 34.	Negative settling time 1%	13
Figure 35.	48 V common-mode positive step response recovery	13
Figure 36.	48 V common-mode negative step response recovery	13
Figure 37.	100 V common-mode positive step response recovery	14
Figure 38.	100 V common-mode negative step response recovery	14
Figure 39.	PSRR vs. frequency	14
Figure 40.	CMRR vs. frequency	14
Figure 41.	Positive overvoltage recovery	14
Figure 42.	Negative overvoltage recovery	14
Figure 43.	Overvoltage recovery vs. V_{icm} , $V_{CC} = 5\text{ V}$	15
Figure 44.	Noise vs. frequency	15
Figure 45.	0.1 Hz to 10 Hz voltage noise	15
Figure 46.	Power up time delay	15
Figure 47.	Output impedance vs. frequency	15
Figure 48.	SO8 package outline	17
Figure 49.	SO8 recommended footprint	18
Figure 50.	MiniSO8 package outline	19
Figure 51.	MiniSO8 recommended footprint	20

IMPORTANT NOTICE – READ CAREFULLY

STMicroelectronics NV and its subsidiaries (“ST”) reserve the right to make changes, corrections, enhancements, modifications, and improvements to ST products and/or to this document at any time without notice. Purchasers should obtain the latest relevant information on ST products before placing orders. ST products are sold pursuant to ST’s terms and conditions of sale in place at the time of order acknowledgment.

Purchasers are solely responsible for the choice, selection, and use of ST products and ST assumes no liability for application assistance or the design of purchasers’ products.

No license, express or implied, to any intellectual property right is granted by ST herein.

Resale of ST products with provisions different from the information set forth herein shall void any warranty granted by ST for such product.

ST and the ST logo are trademarks of ST. For additional information about ST trademarks, refer to www.st.com/trademarks. All other product or service names are the property of their respective owners.

Information in this document supersedes and replaces information previously supplied in any prior versions of this document.

© 2023 STMicroelectronics – All rights reserved