

Multipurpose Boxes with Lids

G2 Series



Multipurpose IP65
ABS



Multipurpose IP65
Polycarbonate

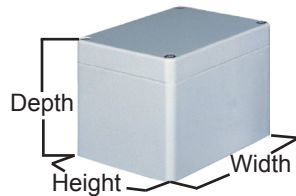

Features:

- The LID and base incorporate a tongue and groove sealing system with a neoprene gasket
- Wall mounting holes and LID fixing screws are outside the sealing area thus preventing the ingress of moisture and dust
- Designed to IP 65 of IEC 529 and nema 4 (dust and hoseproof)
- Internal guide slots for mounting PCB assemblies vertically
- Bosses on internal base allow fixing of PCB's horizontally or connection of terminals, etc into threaded brass inserts
- LID fixing screw are M-4 stainless steel (nonmagnetic) into threaded brass inserts
- Polycarbonate is an engineering thermoplastic that has good electrical insulation characteristic and heat resistance which make them ideal for use in the electrical and electronics industries
- Available with Nickel Acrylic coating on the internal surfaces which improves EMI and RFI shielding of the enclosure

Specifications:

Type : IP65, PC (Polycarbonate boxes sealed to IP65)
 Wall Thickness : 3mm
 Colour : Light Grey
 Operating Temperature : -40°C to +125°C

Dimensions of Boxes

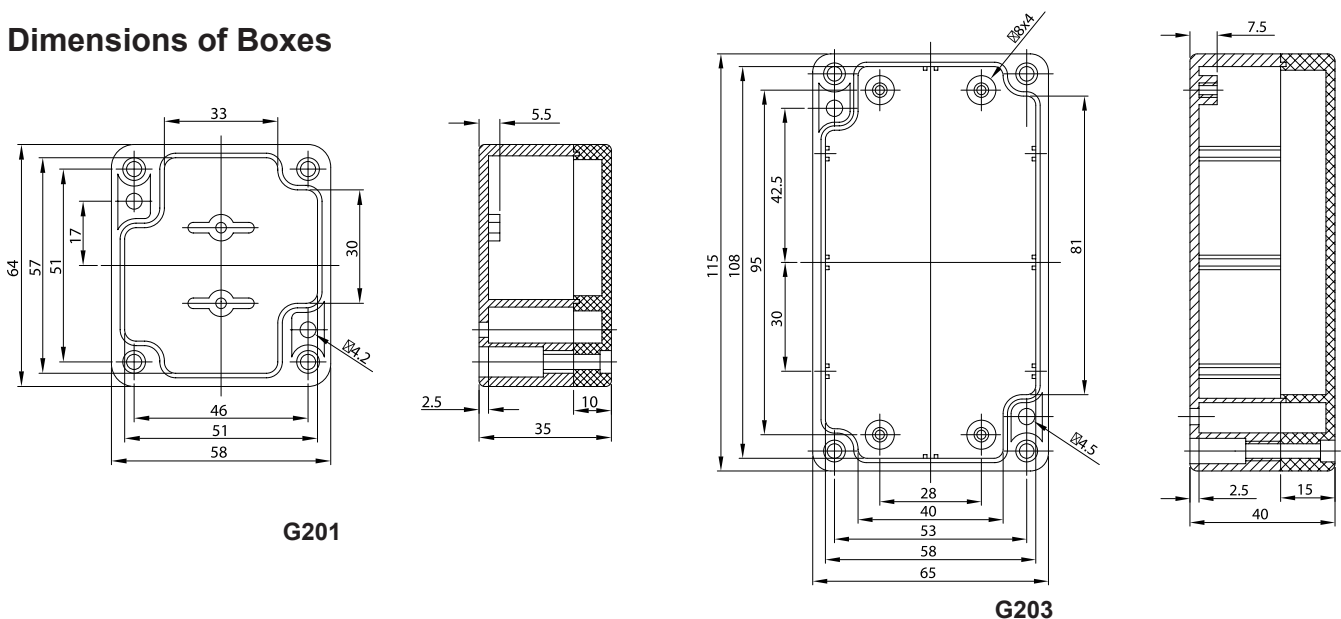

Dimensions : Millimetres

www.element14.com
www.farnell.com
www.newark.com



Multipurpose Boxes with Lids

G2 Series

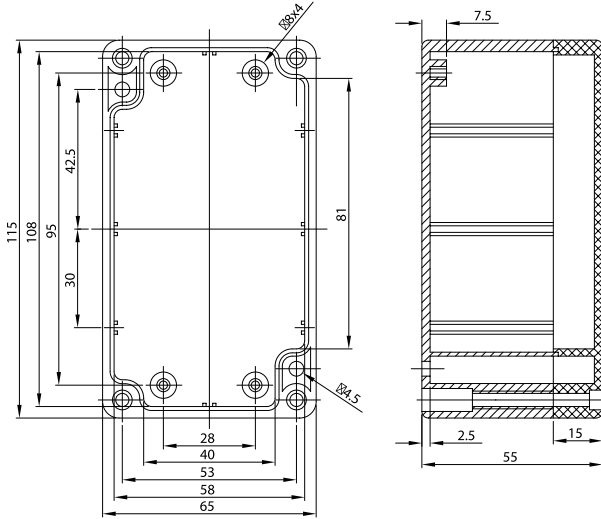

G205

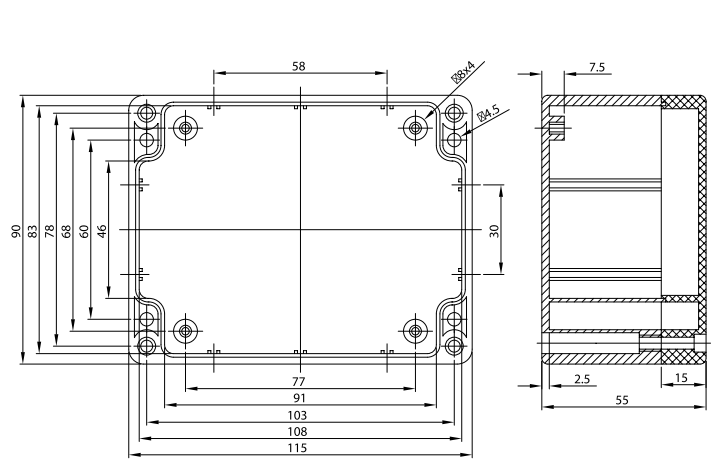

G212

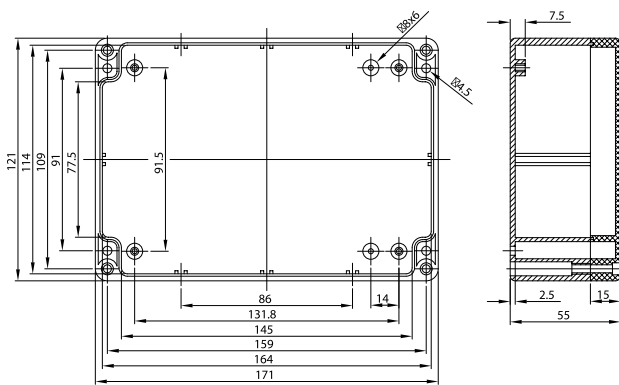

G214

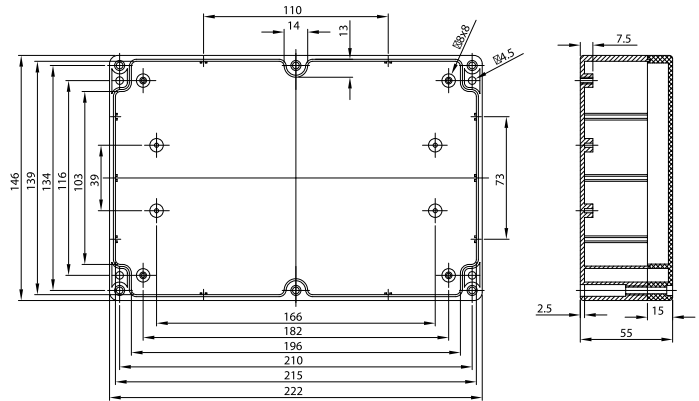

G218

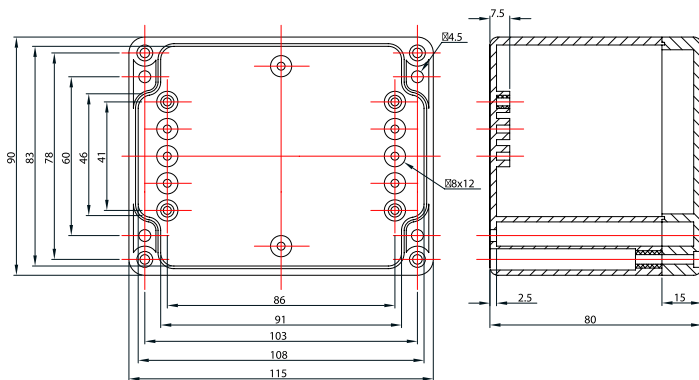

G221

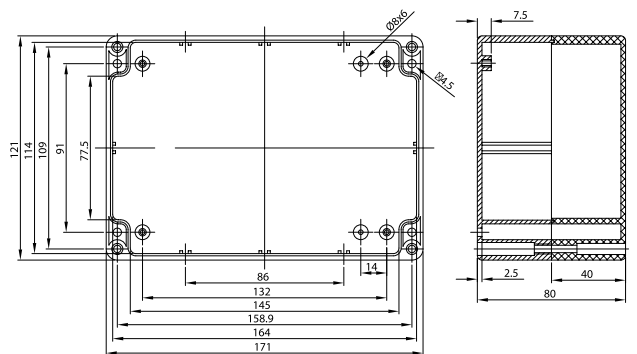

G223

Dimensions : Millimetres

www.element14.com
www.farnell.com
www.newark.com



Multipurpose Boxes with Lids

G2 Series

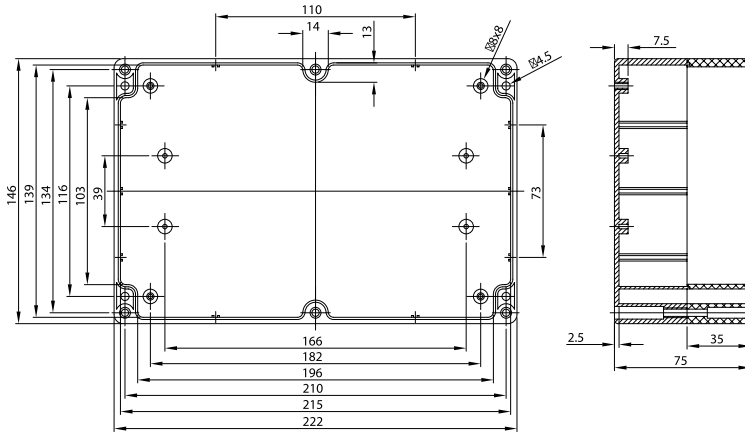

G232

Dimensions : Millimetres

Part Number Table

Description	External Dimensions (W × H × D) mm	Part Number
Sealed Polycarbonate and ABS Enclosures	64 × 58 × 35	G201
	115 × 65 × 40	G203
	115 × 65 × 55	G205
	115 × 90 × 55	G212
	171 × 121 × 55	G214
	222 × 146 × 55	G218
	115 × 90 × 80	G221
	171 × 121 × 80	G223
	222 × 146 × 75	G232

Important Notice : This data sheet and its contents (the "Information") belong to the members of the Premier Farnell group of companies (the "Group") or are licensed to it. No licence is granted for the use of it other than for information purposes in connection with the products to which it relates. No licence of any intellectual property rights is granted. The Information is subject to change without notice and replaces all data sheets previously supplied. The Information supplied is believed to be accurate but the Group assumes no responsibility for its accuracy or completeness, any error in or omission from it or for any use made of it. Users of this data sheet should check for themselves the Information and the suitability of the products for their purpose and not make any assumptions based on information included or omitted. Liability for loss or damage resulting from any reliance on the Information or use of it (including liability resulting from negligence or where the Group was aware of the possibility of such loss or damage arising) is excluded. This will not operate to limit or restrict the Group's liability for death or personal injury resulting from its negligence. Multicomp is the registered trademark of the Group. © Premier Farnell plc 2012.

www.element14.com
www.farnell.com
www.newark.com

