

DESIGNED & DIMENSIONED
IN MILLIMETERS [INCHES]

SS4-XX-X.XX-X-D-X-XX-TR

DO NOT
SCALE FROM
THIS PRINT

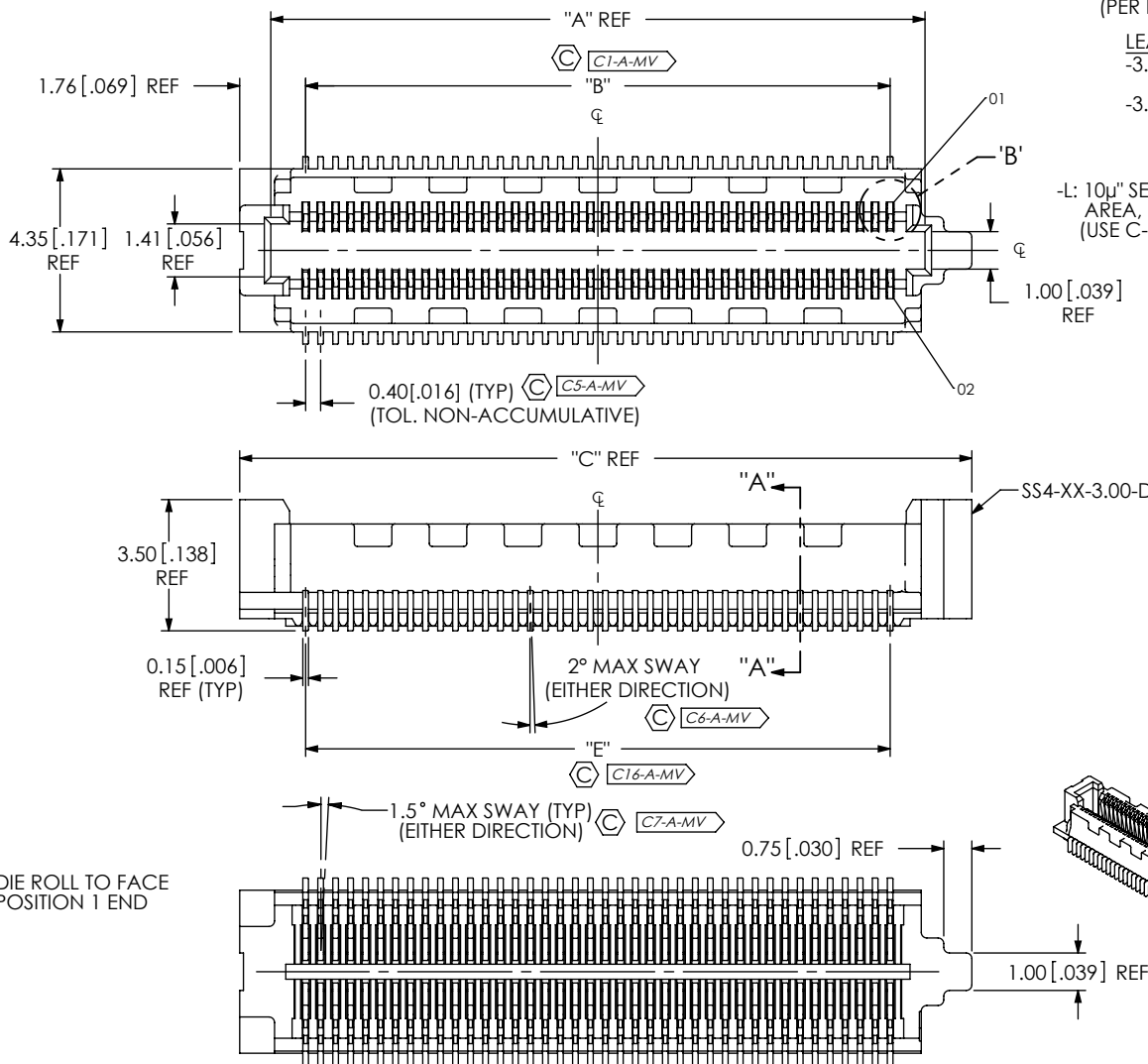

No OF POSITIONS
-10, -15, -20, -30, -40, -50
(PER ROW)

LEAD STYLE
-3.00: SEE FIG 1
(USE C-229-3.00-X)
-3.50: SEE FIG 2, SHT 2
(USE C-229-3.50-X)

PLATING
-L: 10μ" SELECTIVE GOLD IN CONTACT
AREA, MATTE TIN ON TAIL
(USE C-229-X.XX-X)

ROW SPECIFICATION
-D: DOUBLE

PACKAGING
-TR: TAPE AND REEL
PACKAGING
(SEE NOTE 4)

PLACEMENT PAD
-K: KAPTON PAD
(USE K-DOT-.138-.250-.005)
(SEE FIG 4 & 5, SHT 3)
**PA: PICK & PLACE WITH
ALIGNMENT PINS
(SEE FIG 6, SHT 4)
(NOT AVAILABLE IN -15 POS)

OPTIONS
*, **L: LATCHING
(USE WT-40-X.XX-T)
(SEE FIG 3, SHT 2 AND NOTE 3)
(LEAVE BLANK FOR NO OPTION)

* = TOOLED ONLY FOR THE -3.00 LEAD STYLE
** = AVAILABLE FOR EXISTING CUSTOMERS ONLY

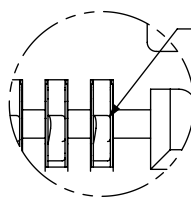
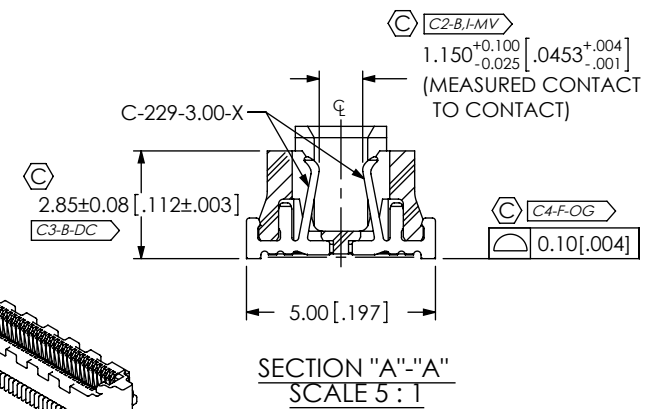

DETAIL 'B'
SCALE 15:1

POS	"A"	"B"	"C"	"E"
-10	5.46 [0.215]	3.60 [0.142]	7.54 [0.297]	3.60 [0.142]
-15	7.46 [0.294]	5.60 [0.220]	9.54 [0.376]	5.60 [0.220]
-20	9.46 [0.372]	7.60 [0.299]	11.54 [0.454]	7.60 [0.299]
-30	13.46 [0.530]	11.60 [0.457]	15.54 [0.612]	11.60 [0.457]
-40	17.46 [0.687]	15.60 [0.614]	19.54 [0.769]	15.60 [0.614]
-50	21.46 [0.845]	19.60 [0.772]	23.54 [0.927]	19.60 [0.772]

FIG 1
SS4-40-3.00-L-D SHOWN

SS4 LEAD STYLE	STACK HEIGHT		
	ST4 LEAD STYLE		
-1.00	-1.00	-1.50	-2.50
-3.00	4.0[.16]	4.5[.18]	5.5[.22]
-3.50	4.5[.18]	5.0[.20]	6.0[.24]

NOTES:

- ⊕ REPRESENTS A CRITICAL DIMENSION.
- MINIMUM PUSHOUT FORCE: 1.11N [.25 LB].
- L: LATCHING OPTION NOT INTENDED FOR ALIGNMENT TO PCB. AUTOMATED PLACEMENT IS RECOMMENDED.
- FOR QUANTITIES UP TO 49 PIECES, NO LEADER, TRAILER, OR REEL WILL BE SUPPLIED. FOR QUANTITIES OF 50-124 PIECES, NO LEADER OR TRAILER WILL BE SUPPLIED.

CPC FREQUENCY THIS SHEET	UNLESS OTHERWISE SPECIFIED, DIMENSIONS ARE IN MILLIMETERS. TOLERANCES ARE: DECIMALS ANGLES .X: ±0.3 [.01] 2° .XX: ±0.13 [.005] .XXX: ±0.051 [.0020]	PROPRIETARY NOTE THIS DOCUMENT CONTAINS INFORMATION CONFIDENTIAL AND PROPRIETARY TO SAMTEC, INC. AND SHALL NOT BE REPRODUCED OR TRANSFERRED TO OTHER DOCUMENTS OR DISCLOSED TO OTHERS OR USED FOR ANY PURPOSE OTHER THAN THAT WHICH IT WAS OBTAINED WITHOUT THE EXPRESSED WRITTEN CONSENT OF SAMTEC, INC.
A C1, C5, C6, C7, C16, C17	DO NOT SCALE DRAWING SHEET SCALE: 2:1	
B C2, C3	MATERIAL: INSULATOR: LCP, UL 94 V0, COLOR: BLACK CONTACT: PHOS BRONZE LATCH: PHOS BRONZE	
C		
F C4		

samtec

520 PARK EAST BLVD, NEW ALBANY, IN 47150
PHONE: 812-944-6733 FAX: 812-948-5047
e-Mail: info@SAMTEC.com code: 55322

DESCRIPTION:
0.4mm [.016] SOCKET STRIP ASSEMBLY

DWG. NO.
SS4-XX-X.XX-X-D-X-XX-TR

BY: CLAY W 4/19/2007 SHEET 1 OF 4

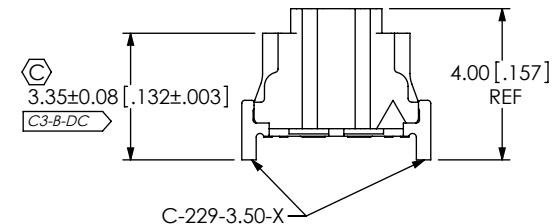
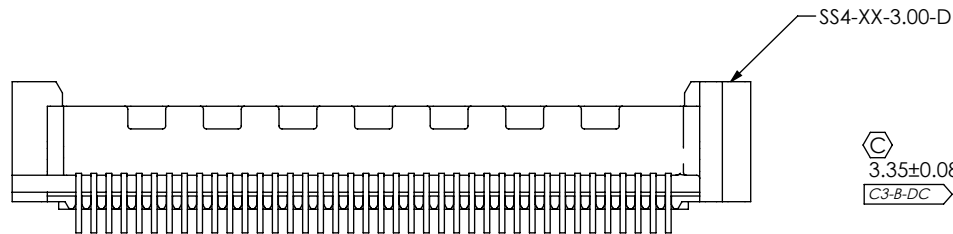

FIG 2
-3.50 BODY HEIGHT
SS4-40-3.50-X-D SHOWN
(DIFFERENT AS SHOWN, OTHERWISE SAME AS FIG 1)

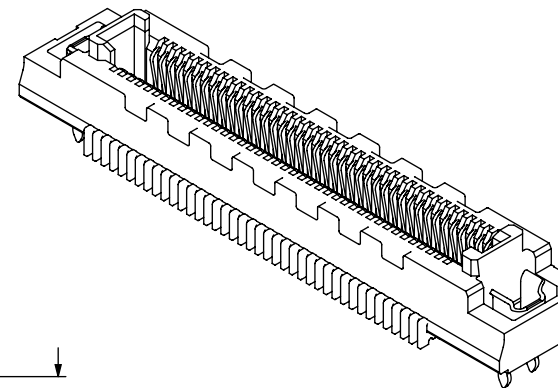
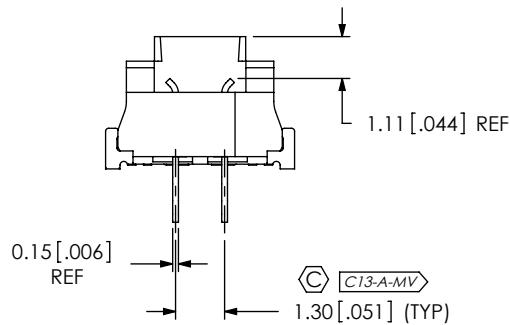
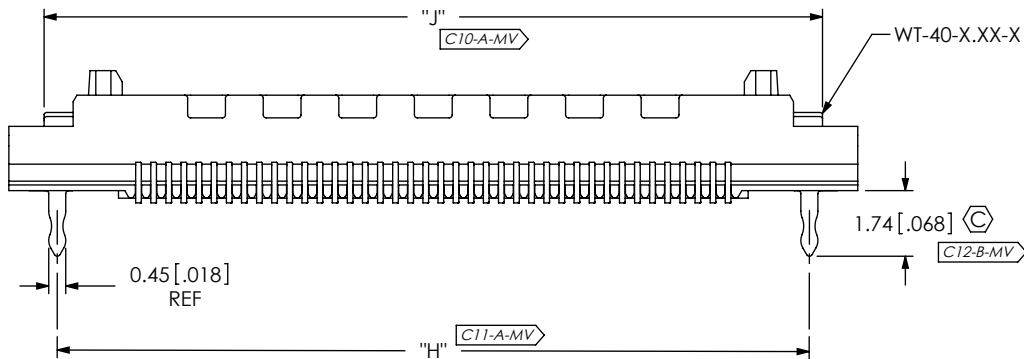
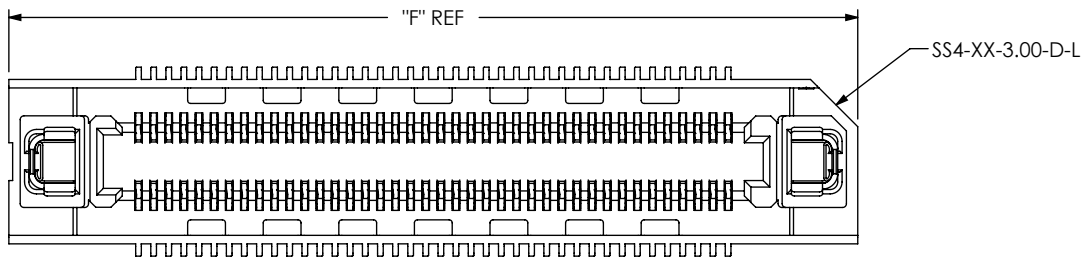

FIG 3
* **-L: LATCHING OPTION
SS4-40-3.00-X-D-L SHOWN
(DIFFERENT AS SHOWN, OTHERWISE SAME AS FIG 1)
* = TOOLED ONLY FOR THE -3.00 LEAD STYLE
** = AVAILABLE FOR EXISTING CUSTOMERS ONLY

POS	"F"	"H"	"J"
-10	10.46 [0.412]	7.90 [0.311]	8.60 [0.339]
-15	12.46 [0.491]	9.90 [0.390]	10.60 [0.417]
-20	14.46 [0.569]	11.90 [0.469]	12.60 [0.496]
-30	18.46 [0.727]	15.90 [0.626]	16.60 [0.654]
-40	22.46 [0.884]	19.90 [0.783]	20.60 [0.811]
-50	26.46 [1.042]	23.90 [0.941]	24.60 [0.969]

LEAD STYLE	LATCH
-3.00	W-40-3.00-T
-3.50	*WT-40-3.50-T

(* = NOT TOOLED)

CPC FREQUENCY THIS SHEET	
A	C10,C11, C12,C13
B	C3
C	
D	

PROPRIETARY NOTE
THIS DOCUMENT CONTAINS INFORMATION CONFIDENTIAL AND PROPRIETARY TO SAMTEC, INC. AND SHALL NOT BE REPRODUCED OR TRANSFERRED TO OTHER DOCUMENTS OR DISCLOSED TO OTHERS OR USED FOR ANY PURPOSE OTHER THAN THAT WHICH IT WAS OBTAINED WITHOUT THE EXPRESSED WRITTEN CONSENT OF SAMTEC, INC.

DO NOT SCALE DRAWING

SHEET SCALE: 5:1

520 PARK EAST BLVD, NEW ALBANY, IN 47150
PHONE: 812-944-6733 FAX: 812-948-5047
e-Mail: info@SAMTEC.com code: 55322

DESCRIPTION:
0.4mm[.016] SOCKET STRIP ASSEMBLY

DWG. NO.
SS4-XX-X.XX-X-D-X-XX-TR

BY: CLAY W 4/19/2007 SHEET 2 OF 4

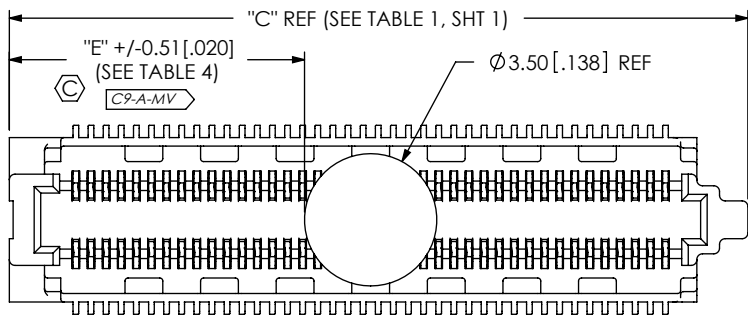
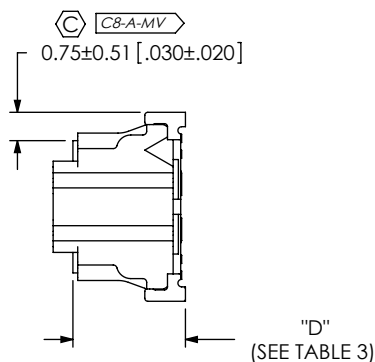

FIG 4
 -K: KAPTON OPTION
 SS4-40-3.00-X-D-K SHOWN
 (DIFFERENT AS SHOWN, OTHERWISE SAME AS FIG 1)



LEAD STYLE	"D"
-3.00	2.98 [.117]
-3.50	3.48 [.137]

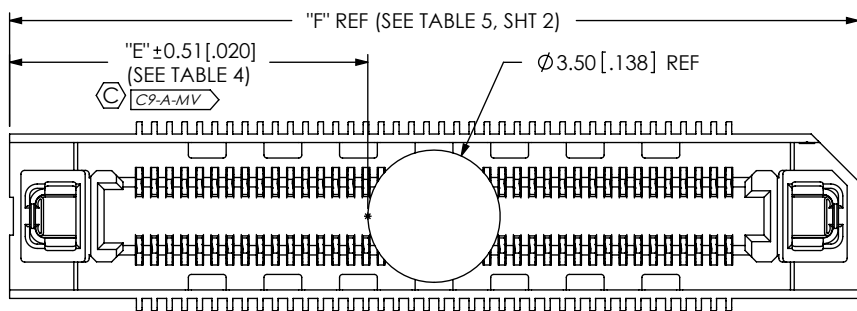
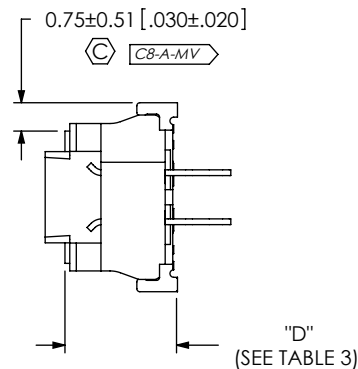

FIG 5
 -K: KAPTON OPTION(W/ -L OPTION)
 SS4-40-3.00-X-D-L-K SHOWN
 (DIFFERENT AS SHOWN, OTHERWISE SAME AS FIG 1)



POS	"E"	"E"
	W/O -L OPTION	W/ -L OPTION
-10	1.48 [0.058]	3.48 [0.137]
-15	2.48 [0.098]	4.48 [0.176]
-20	3.48 [0.137]	5.48 [0.216]
-30	5.48 [0.216]	7.48 [0.294]
-40	7.48 [0.294]	9.48 [0.373]
-50	9.48 [0.373]	11.48 [0.452]

CRITICAL DIMENSION INSPECTION INSTRUCTION TABLE

ASSEMBLY OPERATION	IN-PROCESS INSPECTION
FILL CONTACTS	C1, C2, C3, C5, C6, C7, C16, C17
FILL LATCHES	C10, C11, C12, C13
APPLY KAPTON	C8, C9
APPLY PICK & PLACE PAD	C14

CPC FREQUENCY THIS SHEET	
A	C8, C9
B	
C	
D	

PROPRIETARY NOTE
 THIS DOCUMENT CONTAINS INFORMATION CONFIDENTIAL AND PROPRIETARY TO SAMTEC, INC. AND SHALL NOT BE REPRODUCED OR TRANSFERRED TO OTHER DOCUMENTS OR DISCLOSED TO OTHERS OR USED FOR ANY PURPOSE OTHER THAN THAT WHICH IT WAS OBTAINED WITHOUT THE EXPRESSED WRITTEN CONSENT OF SAMTEC, INC.

DO NOT SCALE DRAWING
 SHEET SCALE: 5:1



520 PARK EAST BLVD, NEW ALBANY, IN 47150
 PHONE: 812-944-6733 FAX: 812-948-5047
 e-Mail: info@SAMTEC.com code: 55322

DESCRIPTION:
 0.4mm[.016] SOCKET STRIP ASSEMBLY
 DWG. NO.
 SS4-XX-X.XX-X-D-X-XX-TR

BY: CLAY W 4/19/2007 SHEET 3 OF 4

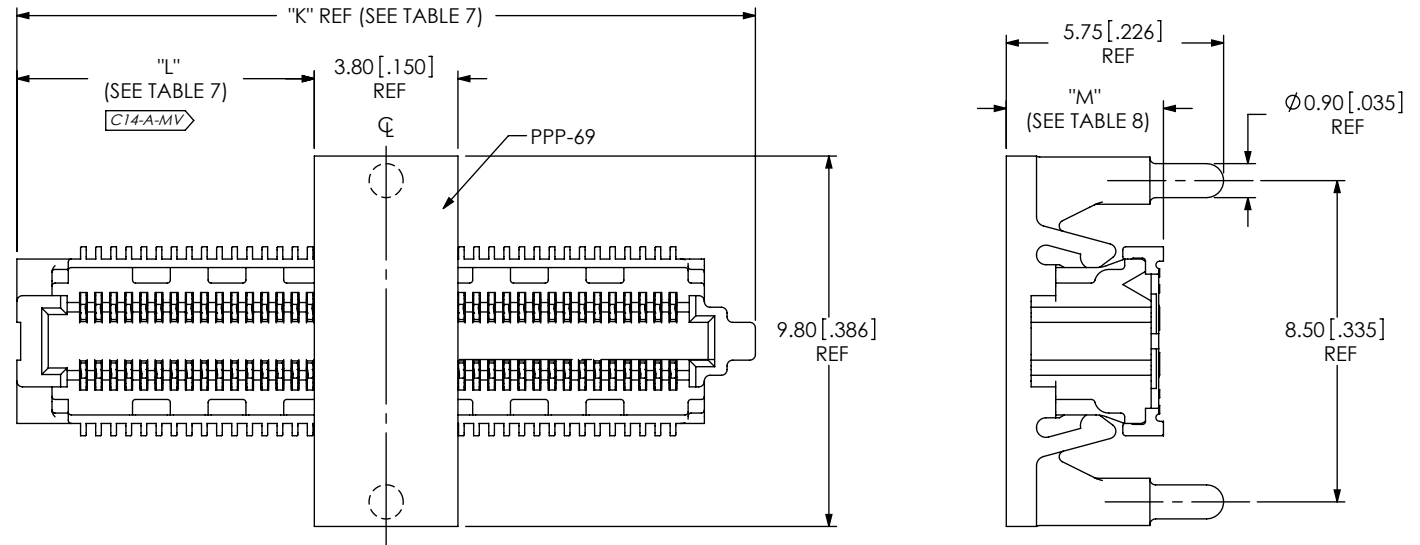

FIG 6
 **-PA: PICK & PLACE PAD WITH ALIGNMENT PINS
 SS4-40-3.00-X-D-PA SHOWN
 (DIFFERENT AS SHOWN, OTHERWISE SAME AS FIG 1)
 (NOT AVAILABLE IN -15 POS)
 ** = AVAILABLE FOR EXISTING CUSTOMERS ONLY

LEAD STYLE	"M"
-3.00	4.16 [.164]
-3.50	4.66 [.183]

POS	"K"	"K"	"L"	"L"
	W/O -L OPTION	W/ -L OPTION	W/O -L OPTION	W/ -L OPTION
-10	7.54 [0.297]	10.46 [0.412]	1.87 [0.074]	3.33 [0.131]
-20	11.54 [0.454]	14.46 [0.569]	3.87 [0.152]	5.33 [0.210]
-30	15.54 [0.612]	18.46 [0.727]	5.87 [0.231]	7.33 [0.289]
-40	19.54 [0.769]	22.46 [0.884]	7.87 [0.310]	9.33 [0.367]
-50	23.54 [0.927]	26.46 [1.042]	9.87 [0.389]	11.33 [0.446]

CPC FREQUENCY THIS SHEET	
A	C14
B	
C	
D	

PROPRIETARY NOTE
 THIS DOCUMENT CONTAINS INFORMATION CONFIDENTIAL AND PROPRIETARY TO SAMTEC, INC. AND SHALL NOT BE REPRODUCED OR TRANSFERRED TO OTHER DOCUMENTS OR DISCLOSED TO OTHERS OR USED FOR ANY PURPOSE OTHER THAN THAT WHICH IT WAS OBTAINED WITHOUT THE EXPRESSED WRITTEN CONSENT OF SAMTEC, INC.

DO NOT SCALE DRAWING

SHEET SCALE: 5:1

samtec

520 PARK EAST BLVD, NEW ALBANY, IN 47150
 PHONE: 812-944-6733 FAX: 812-948-5047
 e-Mail: info@SAMTEC.com code: 55322

DESCRIPTION:
 0.4mm[.016] SOCKET STRIP ASSEMBLY

DWG. NO.
SS4-XX-X.XX-X-D-X-XX-TR

BY: CLAY W 4/19/2007 SHEET 4 OF 4