

NOTES: [AO]

1. Ⓢ REPRESENTS A CRITICAL DIMENSION.
2. MAXIMUM PIN ROTATION: 2°.
3. MINIMUM PUSHOUT FORCE: 1 LB.
4. NOTE DELETED.
5. MINIMUM RETENTION FOR LOCKING CLIPS: 12 OZ.
6. MUST BE MEASURED AT BEND.
7. DUE TO THE HIGH AMOUNT OF INSERTION FORCE NEEDED, THE -LC OPTION IS NOT COMPATIBLE WITH AUTO PLACEMENT. SAMTEC RECOMMENDS MANUAL PLACEMENT FOR ALL ASSEMBLIES WITH THE -LC OPTION.

DO NOT SCALE FROM THIS PRINT

LTMM-1XX-XX-XX-D-XX-XX

No OF POSITIONS
-02 THRU -25

POLARIZED OPTION
XX INDICATES POS TO BE OMMITTED

TERMINAL STYLE
-01: .100[2.54] POST HEIGHT (STANDARD)
-02: .120[3.05] POST HEIGHT (SEE TABLE 1)

PLATING SPECIFICATION
[AO] -G: 20μ" SELECTIVE GOLD IN CONTACT AREA, 3μ" SELECTIVE GOLD ON TAIL
-T: MATTE TIN CONTACT AND TAIL
-S: 30μ" SELECTIVE GOLD IN CONTACT AREA, MATTE TIN ON TAIL
-L: 15μ" SELECTIVE GOLD IN CONTACT AREA, MATTE TIN ON TAIL
-F: 3μ" SELECTIVE GOLD IN CONTACT AREA, MATTE TIN ON TAIL
-H: 30μ" SELECTIVE GOLD IN CONTACT AREA, 3μ" SELECTIVE GOLD ON TAIL
-SM: 30μ" SELECTIVE GOLD IN CONTACT AREA, MATTE TIN ON TAIL
-TM: MATTE TIN ON ENTIRE PIN
-LM: 15μ" SELECTIVE GOLD IN CONTACT AREA, MATTE TIN ON TAIL
-FM: 3μ" SELECTIVE GOLD IN CONTACT AREA, MATTE TIN ON TAIL

OPTION
LEAVE BLANK FOR THROUGH HOLE (SEE FIG 1 & TABLE 1)
[AO] -RA: RIGHT ANGLE (SEE FIG 2, SHT 2 & TABLE 1)
-SM: SURFACE MOUNT (SEE FIG 3, SHT 3 & TABLE 1)
-LC: LOCKING CLIP (SEE NOTE 7) (USE LC-05-TM FOR TH STYLE, SEE FIG 1) (USE LC-07-TM FOR -SM STYLE, SEE FIG 3, SHT 3) (NOT AVAILABLE FOR -RA STYLE)
-P: PICK & PLACE PAD (USE PPP-24, SEE FIG 4, SHT 2) (-SM OPTION ONLY)
-M: METAL PICK AND PLACE PAD (USE MPP-07, SEE FIG 5, SHT 2) (-SM OPTION ONLY)
-K: POLYAMIDE FILM (SEE FIG 6, SHT 3) (-SM OPTION ONLY)
-TR: TAPE AND REEL (SEE FIG 7, SHT 4) (-SM OPTION ONLY)

ROW SPECIFICATION
-D: DOUBLE (USE LTMM-XX-D-LC)

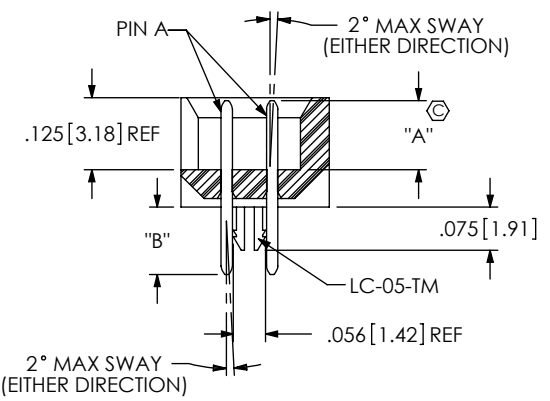
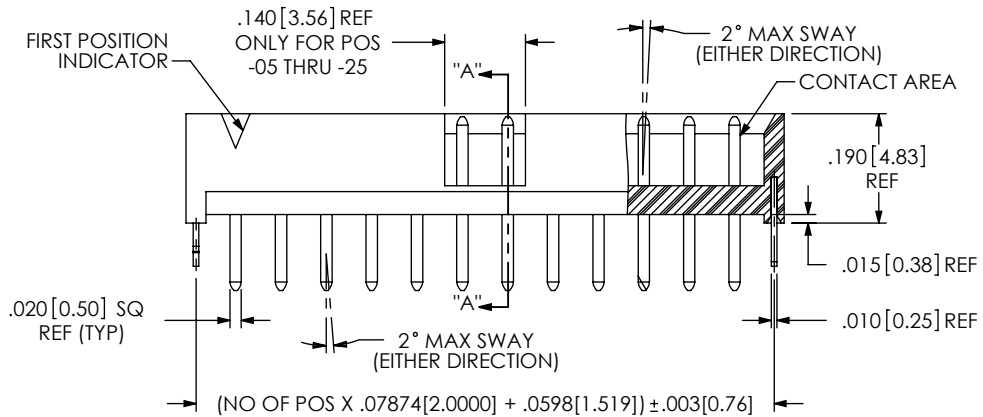
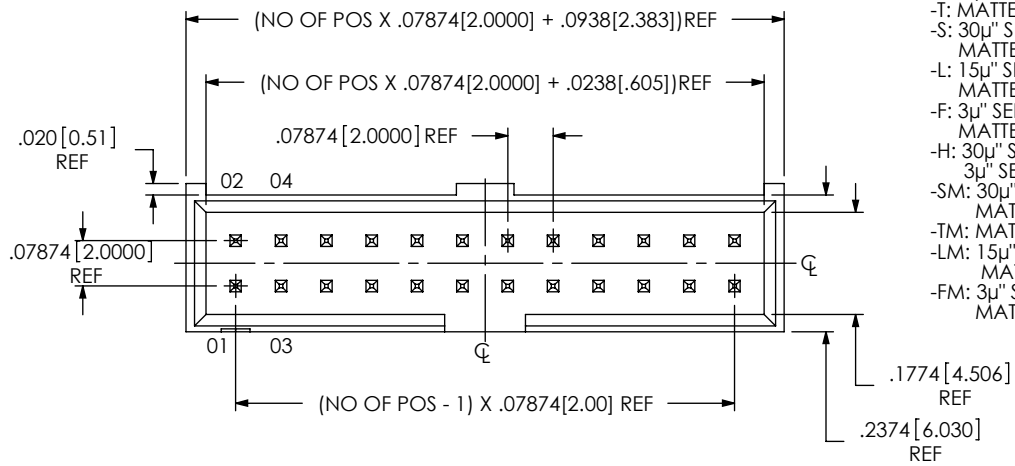

FIG 1 THROUGH HOLE LTMM-112-02-XX-D-LC SHOWN

[AO]

TABLE 1

THROUGH HOLE (SEE FIG 1)	LEAD STYLE	"A"	"B" REF	"C" REF	PIN A	PIN B
	-01	.100 [2.54]	.090 [2.30]	N/A	T-1S13-04-X2	N/A
	-02	.120 [3.05]	.117 [3.00]	N/A	T-1S13-07-X2	N/A
RIGHT ANGLE (SEE FIG 2, SHT 2)	-01	.100 [2.54]	.232 [5.90]	.390 [9.91]	T-1S13-05-X2	T-1S13-06-X2
	-02	.120 [3.05]	.228 [5.80]	.386 [9.80]	T-1S13-19-X2	T-1S13-22-X2
SURFACE MOUNT (SEE FIG 3, SHT 3)	-01	.100 [2.54]	.172 [4.40]	N/A	T-1S13-07-X2	N/A
	-02	.120 [3.05]	.173 [4.40]	N/A	T-1S13-20-X2	N/A

UNLESS OTHERWISE SPECIFIED, DIMENSIONS ARE IN INCHES. TOLERANCES ARE:
DECIMALS ANGLES
.XX: ±.01 [.3] 2°
.XXX: ±.005 [.13]
.XXXX: ±.0020 [.051]

PROPRIETARY NOTE
THIS DOCUMENT CONTAINS INFORMATION CONFIDENTIAL AND PROPRIETARY TO SAMTEC, INC. AND SHALL NOT BE REPRODUCED OR TRANSFERRED TO OTHER DOCUMENTS OR DISCLOSED TO OTHERS OR USED FOR ANY PURPOSE OTHER THAN THAT WHICH IT WAS OBTAINED WITHOUT THE EXPRESSED WRITTEN CONSENT OF SAMTEC, INC.

samtec
520 PARK EAST BLVD, NEW ALBANY, IN 47150
PHONE: 812-944-6733 FAX: 812-948-5047
e-Mail: info@SAMTEC.com code: 55322

MATERIAL: DO NOT SCALE DRAWING SHEET SCALE: 3:1
INSULATOR: LCP, COLOR: BLACK
TERMINAL: PHOSPHER BRONZE

DESCRIPTION: LTMM ASSEMBLY
DWG. NO. LTMM-1XX-XX-XX-D-XX-XX

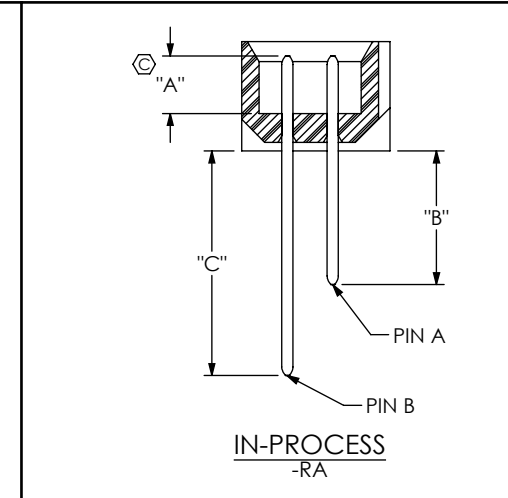
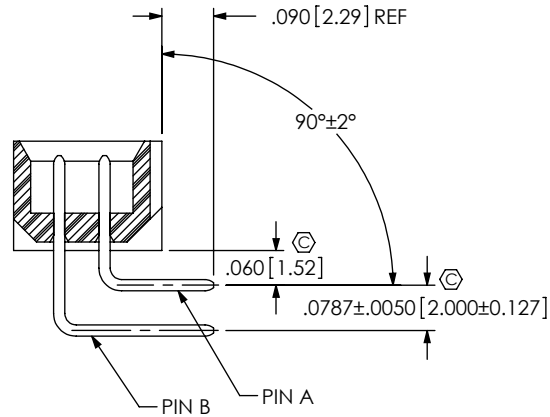
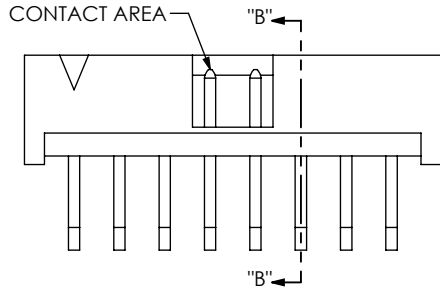
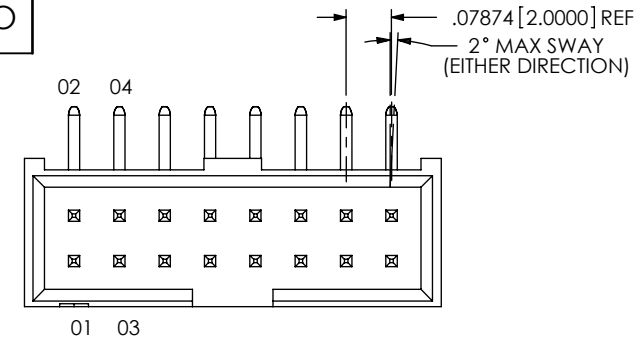

FIG 2

RIGHT ANGLE

LTMM-108-01-XX-D-RA SHOWN

(DIFFERENT AS SHOWN, OTHERWISE SAME AS FIG 1)

AO

NOTE: "R" = USED MEASURED DIMENSION
 "S" = $\{("R"-.250 [6.35]) / 2\} \pm .020 [0.51]$

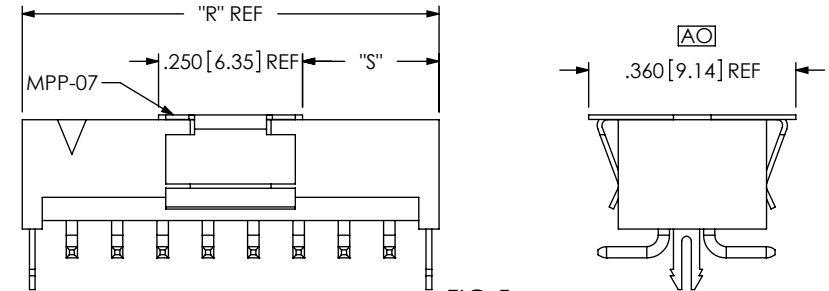

FIG 5

-M: METAL PICK AND PLACE PAD
 LTMM-108-01-XX-D-SM-LC-M SHOWN
 FOR SURFACE MOUNT OPTIONS ONLY

(DIFFERENT AS SHOWN, OTHERWISE SAME AS FIG 3)

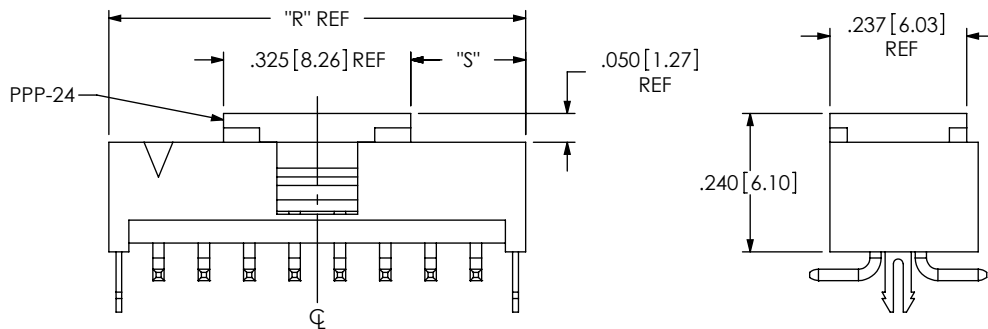

FIG 4

-P: PICK AND PLACE PAD

LTMM-108-01-XX-D-SM-LC-P SHOWN

FOR SURFACE MOUNT OPTIONS ONLY
 (DIFFERENT AS SHOWN, OTHERWISE SAME AS FIG 3)

NOTE: "R" = USED MEASURED DIMENSION
 "S" = $\{("R"-.325 [8.26]) / 2\} \pm .020 [.51]$

PROPRIETARY NOTE

THIS DOCUMENT CONTAINS INFORMATION CONFIDENTIAL AND PROPRIETARY TO SAMTEC, INC. AND SHALL NOT BE REPRODUCED OR TRANSFERRED TO OTHER DOCUMENTS OR DISCLOSED TO OTHERS OR USED FOR ANY PURPOSE OTHER THAN THAT WHICH IT WAS OBTAINED WITHOUT THE EXPRESSED WRITTEN CONSENT OF SAMTEC, INC.

DO NOT SCALE DRAWING

SHEET SCALE: 3:1



520 PARK EAST BLVD, NEW ALBANY, IN 47150
 PHONE: 812-944-6733 FAX: 812-948-5047
 e-Mail: info@SAMTEC.com code: 55322

DESCRIPTION:

LTMM ASSEMBLY

DWG. NO.

LTMM-1XX-XX-XX-D-XX-XX

BY: BRYAN T 05/28/1992 SHEET 2 OF 4

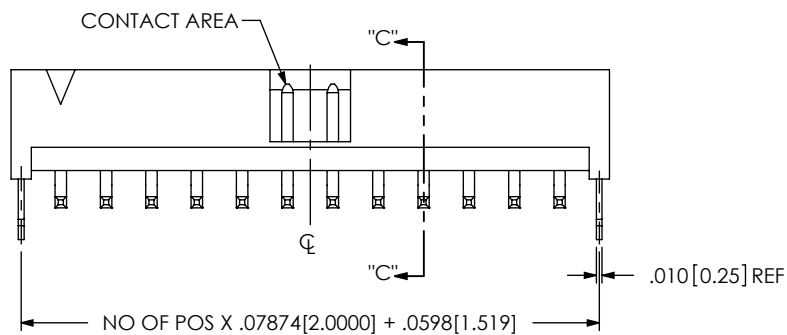
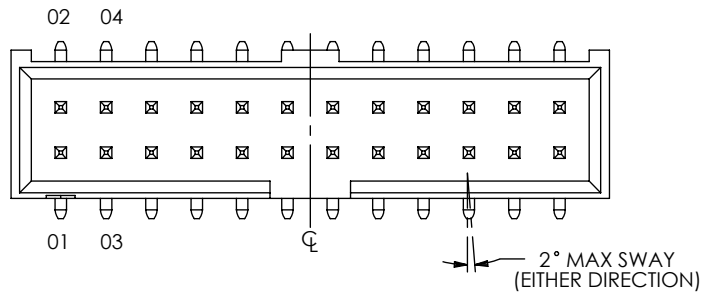
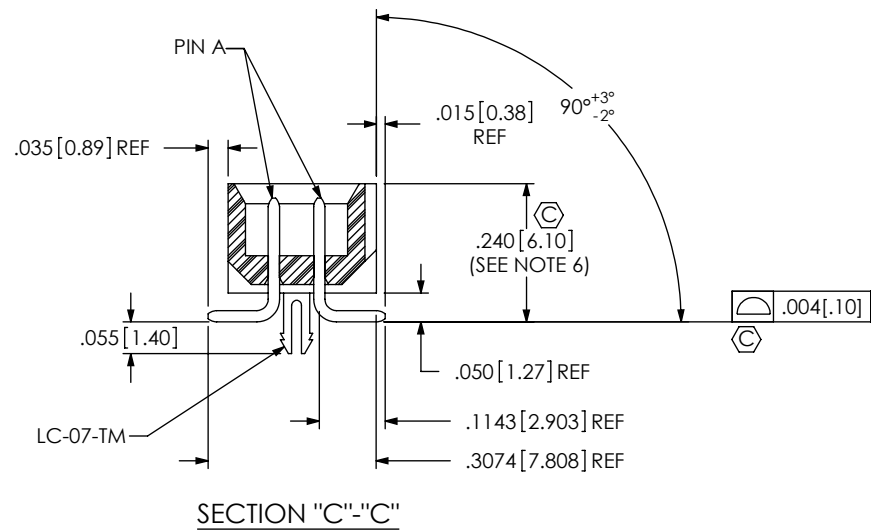
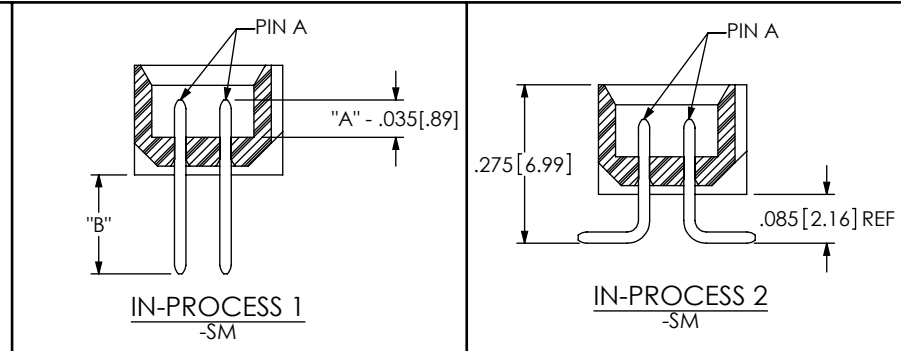

FIG 3 AO
SURFACE MOUNT
LTMM-108-01-XX-D-SM-LC SHOWN
(DIFFERENT AS SHOWN, OTHERWISE SAME AS FIG 1)



SECTION "C"-"C"

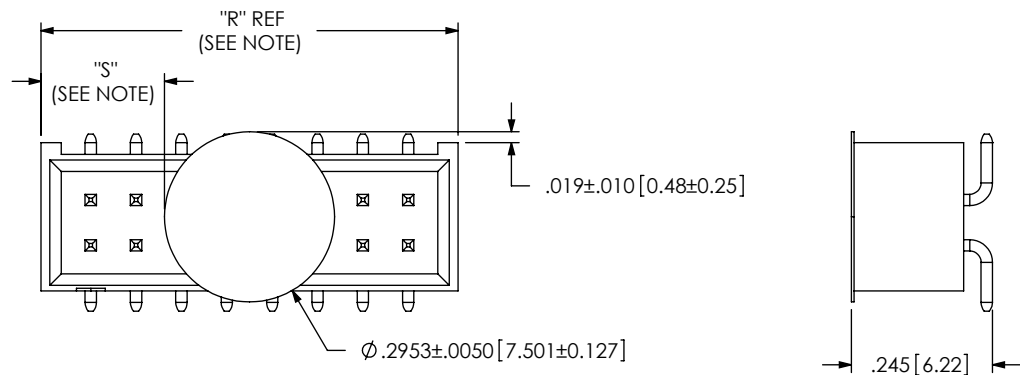

FIG 6 AO
-K OPTION (POLYAMIDE FILM)
LTMM-108-01-XX-D-SM-K SHOWN
FOR SURFACE MOUNT OPTIONS ONLY
(DIFFERENT AS SHOWN, OTHERWISE SAME AS FIG 3)

NOTE: "R" = USED MEASURED DIMENSION
"S" = {("R"-.2953 [7.500]) / 2} ±.020 [.51]

PROPRIETARY NOTE
THIS DOCUMENT CONTAINS INFORMATION
CONFIDENTIAL AND PROPRIETARY TO
SAMTEC, INC. AND SHALL NOT BE REPRODUCED
OR TRANSFERRED TO OTHER DOCUMENTS OR
DISCLOSED TO OTHERS OR USED FOR ANY
PURPOSE OTHER THAN THAT WHICH IT WAS
OBTAINED WITHOUT THE EXPRESSED WRITTEN
CONSENT OF SAMTEC, INC.

DO NOT SCALE DRAWING

SHEET SCALE: 3:1

samtec

520 PARK EAST BLVD, NEW ALBANY, IN 47150
PHONE: 812-944-6733 FAX: 812-948-5047
e-Mail: info@SAMTEC.com code: 55322

DESCRIPTION:
LTMM ASSEMBLY

DWG. NO.
LTMM-1XX-XX-XX-D-XX-XX

BY: BRYAN T 05/28/1992 SHEET 3 OF 4

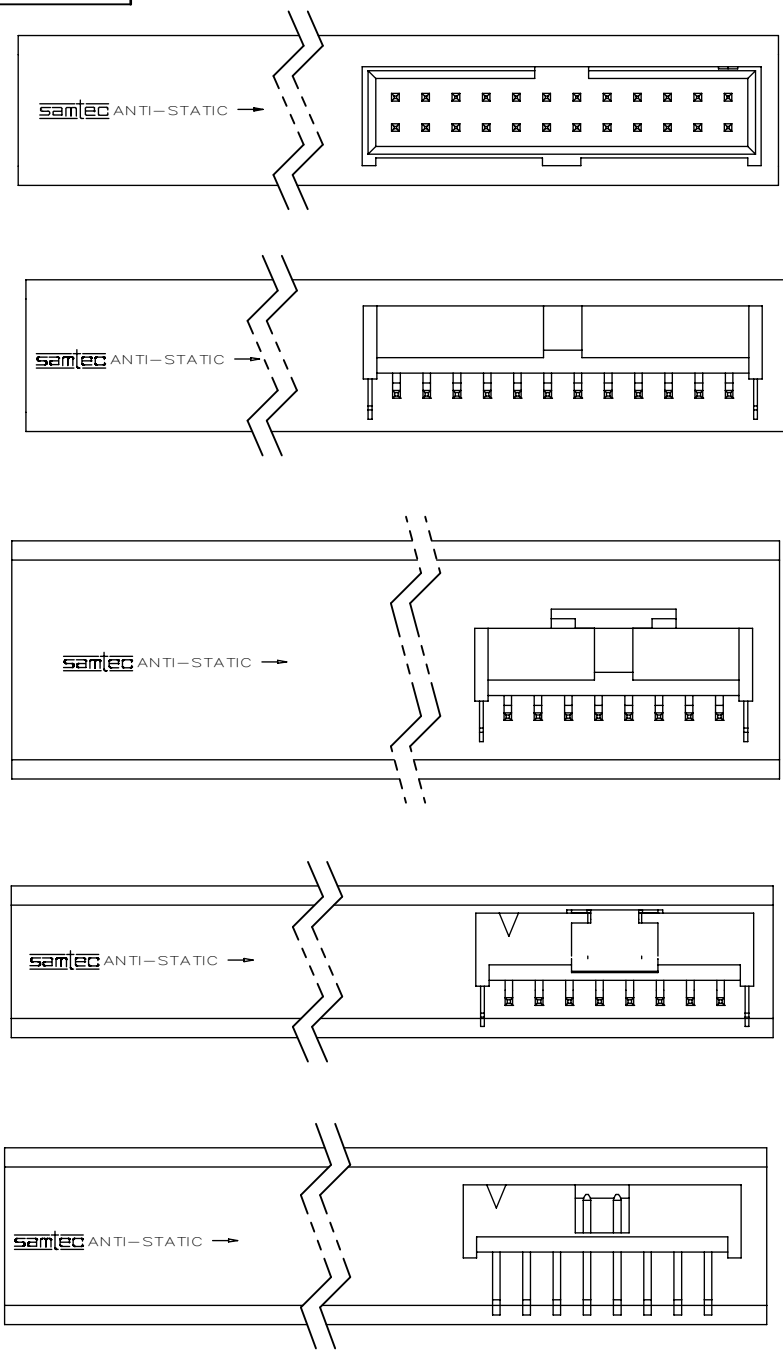

FIG 8
TUBE PACKAGING VIEW

AO

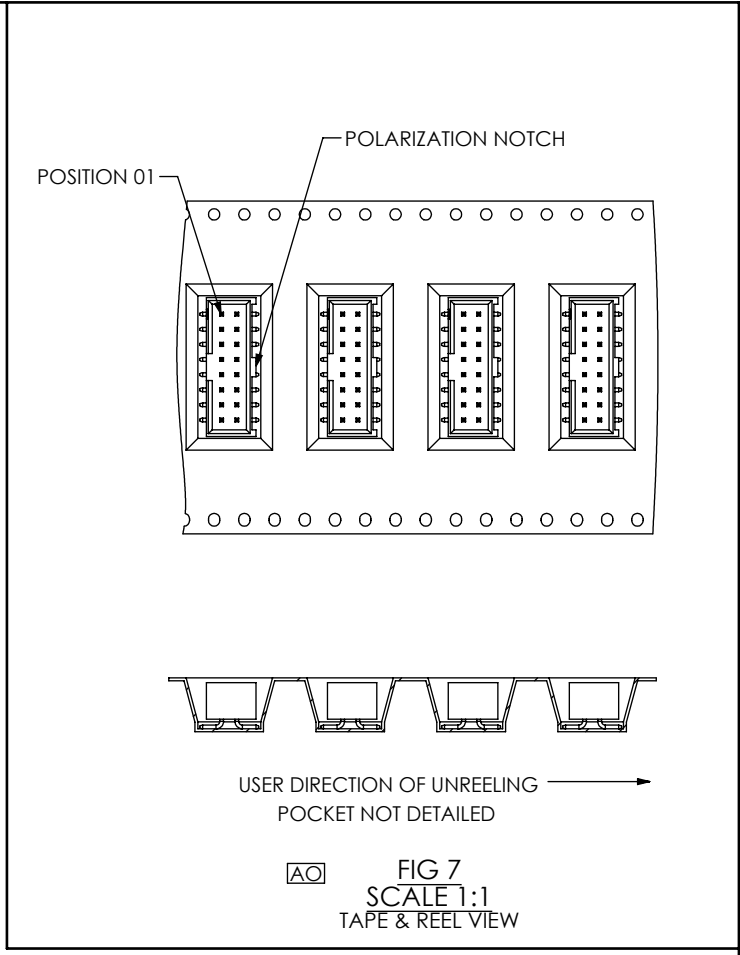
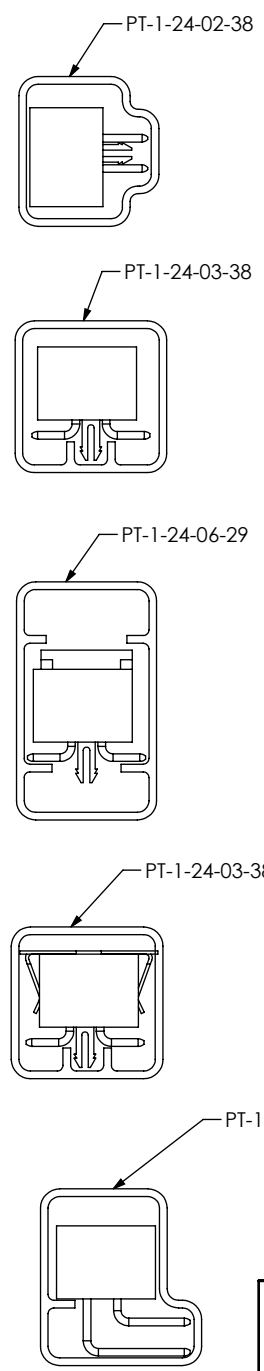

FIG 7
SCALE 1:1
TAPE & REEL VIEW

AO

TABLE 2		
OPTIONS	PACKAGING TUBE	PLUG
STANDARD, -LC	PT-1-24-02-38	TP-03
-SM, -SM-LC, -SM-M	PT-1-24-03-38	TP-03
-SM-LC-P, -SM-P	PT-1-24-06-29	TP-07
-RA	PT-1-24-01-45	TP-03

PROPRIETARY NOTE
THIS DOCUMENT CONTAINS INFORMATION CONFIDENTIAL AND PROPRIETARY TO SAMTEC, INC. AND SHALL NOT BE REPRODUCED OR TRANSFERRED TO OTHER DOCUMENTS OR DISCLOSED TO OTHERS OR USED FOR ANY PURPOSE OTHER THAN THAT WHICH IT WAS OBTAINED WITHOUT THE EXPRESSED WRITTEN CONSENT OF SAMTEC, INC.

DO NOT SCALE DRAWING

SHEET SCALE: 2:1

samtec
520 PARK EAST BLVD, NEW ALBANY, IN 47150
PHONE: 812-944-6733 FAX: 812-948-5047
e-Mail: info@SAMTEC.com code: 55322

DESCRIPTION:
LTMM ASSEMBLY

DWG. NO.
LTMM-1XX-XX-XX-D-XX-XX

BY: BRYAN T 05/28/1992 SHEET 4 OF 4