

- SFM-1XX-XX-XXX-D-XXX
- NO. OF POSITIONS
 ALL POSITIONS AVAILABLE
 -02 THRU -50
 USE BODY: (SFM-XX-D-XX-X)
- LEAD STYLE
- 01: THROUGH HOLE
 USE CONTACT: (C-44-01-XXX)
 (SEE FIG. 1, SHT. 1)
 - 02: SURFACE MOUNT
 USE CONTACT: (C-44-02-XXX)
 (SEE FIG. 2, SHT. 1)
 - 03: STRAIGHT MODIFIED
 USE CONTACT: (C-44-03-XXX)
 (SEE FIG. 1, SHT. 1)
 - L1: THROUGH HOLE (LOW INSERTION)
 USE CONTACT: (C-61-01-XXX)
 (SEE FIG. 1, SHT. 1)
 - L2: SURFACE MOUNT (LOW INSERTION)
 USE CONTACT: (C-61-02-XXX)
 (SEE FIG. 2, SHT. 1)
 - L3: STRAIGHT MODIFIED (LOW INSERTION)
 USE CONTACT: (C-61-03-XXX)
 (SEE FIG. 1, SHT. 1)
 - T1: THROUGH HOLE (PHOS BRONZE)
 USE CONTACT: (C-119-01-XXX)
 (SEE FIG. 1, SHT. 1)
 - T2: SURFACE MOUNT (PHOS BRONZE)
 USE CONTACT: (C-119-02-XXX)
 (SEE FIG. 2, SHT. 1)
- OPTIONS
 (LEAVE BLANK FOR STANDARD AND USE SFM-XX-D)
 -N: NO POLARIZATION NOTCH (USE SFM-XX-D-XX-N)
 -A: ALIGNMENT FIN (USE SFM-XX-D-A-X)
 (SEE FIGURE 6, SHT. 2)
 -LC: LOCKING CLIP (SEE FIGURE 7 & NOTE 8)
 (USE (2) LC-05-TM & SFM-XX-D-LC-X)
 (AVAILABLE ON ALL LEADS)
 -P: PICK AND PLACE PAD (SEE FIG. 6, SHT. 2)
 -TR: TAPE & REEL (SEE FIG. 4, SHT. 3)
 -K: POLYIMIDE FILM PAD (.005 [0.13] THICKNESS WITH SILICONE ADHESIVE)
 (SEE FIG. 3) (USE K-500-300)
 -SN: SOLDER NAIL FOR .062 BOARD (SFM-XX-D-SN AND WT-27-01-T)
 (AVAILABLE WITH LEAD STYLE -02, -L2 & -T2)
 (NOT AVAILABLE WITH OPTIONS -A & -LC)
 -SN2: SOLDER NAIL FOR .093 BOARD (SFM-XX-D-SN AND WT-27-02-T)
 (AVAILABLE WITH LEAD STYLE -02, -L2 & -T2)
 (NOT AVAILABLE WITH OPTIONS -A & -LC)
- BODY SPECIFICATION
 -D: DOUBLE ROW
- PLATING SPECIFICATION
 -S: SELECTIVE, 30 Au / 50 Ni MIN ON CONTACT, MATTE TIN TAIL
 -F: FLASH SELECTIVE, 3 Au / 50 Ni MIN ON CONTACT, MATTE TIN TAIL
 -H: HEAVY GOLD, 30 Au / 50 Ni MIN, 3 Au / 50 Ni MIN ON TAIL
 -L: LIGHT SELECTIVE, 10 Au / 50 Ni MIN ON CONTACT, MATTE TIN TAIL
 -STL: SELECTIVE, 30 Au / 50 Ni MIN ON CONTACT, TIN/LEAD (90/10+/-5%) ON TAIL (ONLY AVAILABLE ON -02 OR -L2 LEADSTYLES)
 -SM: SELECTIVE, 30 Au / 50 Ni MIN ON CONTACT, MATTE TIN TAIL
 -FM: FLASH SELECTIVE, 3 Au / 50 Ni MIN ON CONTACT, MATTE TIN TAIL
 -LM: LIGHT SELECTIVE, 10 Au / 50 Ni MIN ON CONTACT, MATTE TIN TAIL

TABLE 1

| SUFFIX | TAIL LENGTH "A" | TAIL WIDTH "B" |
|--------|-----------------|----------------|
| -X1 | .120 [3.05] | .020 [.51] |
| -X3 | .075 [1.91] | .016 [.41] |

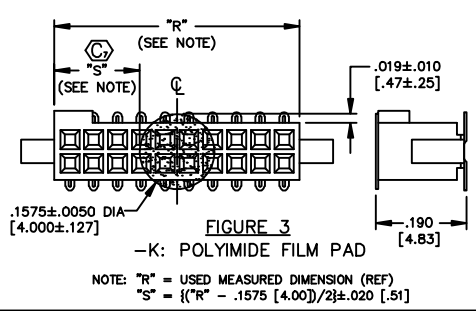
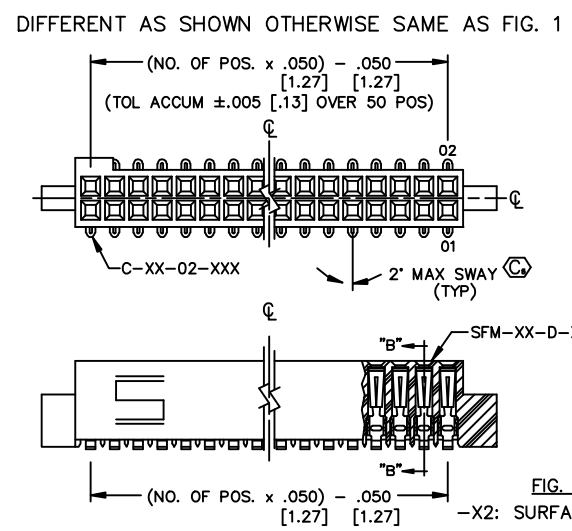

- * = NOT RELEASED
 ** = NOT RELEASED FOR SALE
- NOTES:
 1. MIN. PUSHOUT FORCE: .5 lb.
 2. COPLANARITY: .004-PIN .05 THRU 26
 .006-POS 27 THRU 50
 3. (C) REPRESENTS CRITICAL DIMENSION
 4. TUBE ALL POSITIONS. PARTS TO BE TUBED WITH NOTCH GOING WITH THE ARROW.
 5. PINS CAN BE ORIENTED IN ANY DIRECTION; BOTH ROWS MUST FACE SAME WAY.
 6. SEE NOTCH FOR PROPER ORIENTATION.
 7. .003 [.08] MAXIMUM PIN HEIGHT VARIATION BETWEEN ANY TWO PINS.

PROPRIETARY NOTE
 THIS DOCUMENT CONTAINS INFORMATION CONFIDENTIAL AND PROPRIETARY TO SAMTEC INC. AND SHALL NOT BE REPRODUCED OR TRANSMITTED TO OTHER DOCUMENTS OR DISCLOSED TO OTHERS OR USED FOR ANY PURPOSE OTHER THAN THAT FOR WHICH IT WAS OBTAINED WITHOUT THE EXPRESSED WRITTEN CONSENT OF SAMTEC INC.

MATERIAL:
 INSULATOR:
 LCP: UL 94 VO
 COLOR: BLACK
 CONTACT MATERIAL:
 TIGER EYE = 80Cu
 TIGER EYE LITE = PHOSPHOR BRONZE

EXISPROD\ASSEMBLY\050 SFM-ASM1
samtec
 520 PARK EAST BLVD. NEW ALBANY, INDIANA 47150
 PHONE (812) 944-6733 P.O. BOX 1147
 CODE 55322