

DO NOT SCALE FROM THIS PRINT

No OF POSITIONS
-05, -10, -15, -20, -25, -30

STYLE
**S: SINGLE ENDED
-D: DOUBLE ENDED
-R: REVERSE STIFFENER

STRIP LENGTH
-2: .079 [2.00]
* -4: .157 [4.00]
-6: .236 [6.00]

LENGTH
-XX: "XX" INCHES ±.125 [3.18] INCH
(-S STYLE 2.500 [63.50] MIN)
(-D & -R STYLE 2.000 [50.80] MIN)

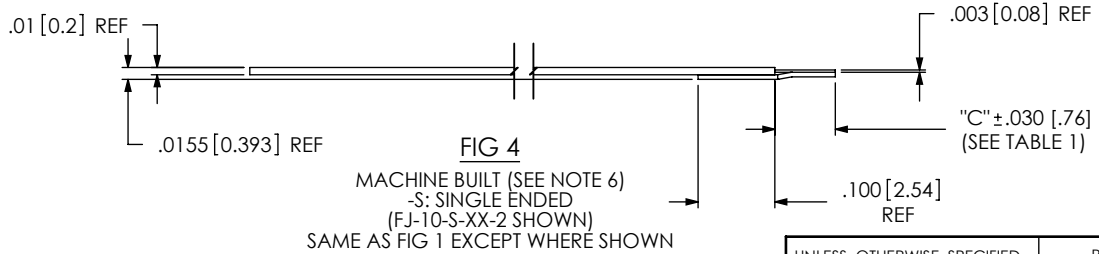
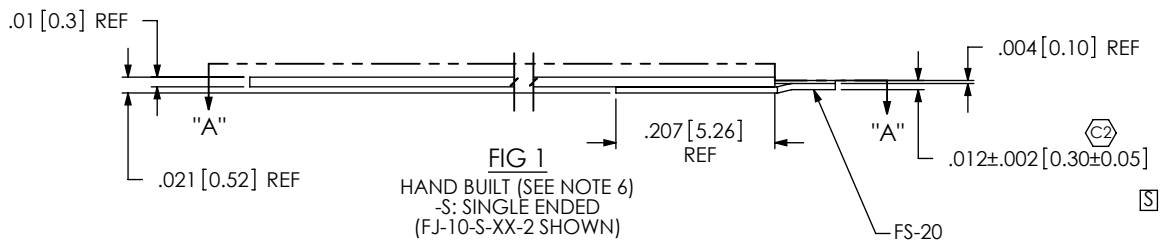
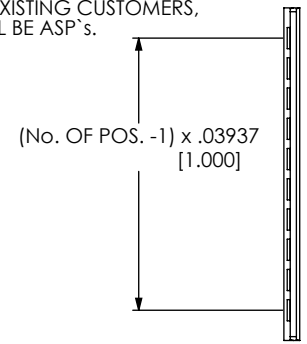
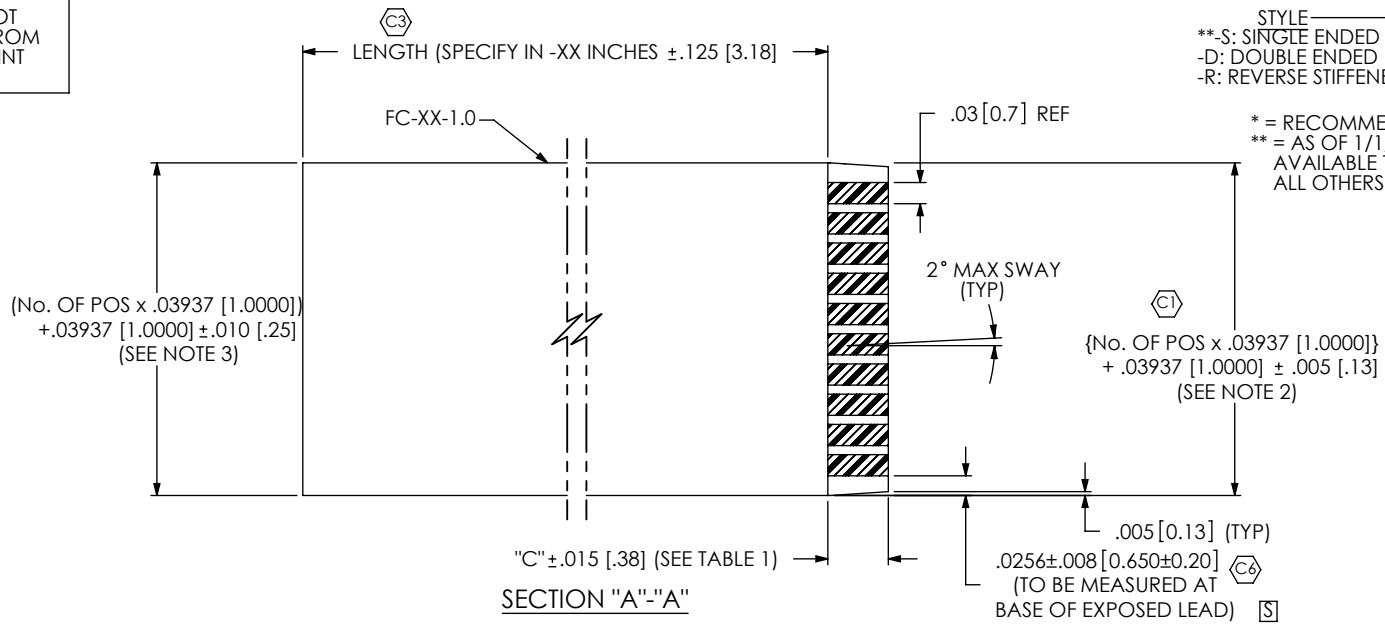

STRIP LENGTH	"C"
-2	.079 [2.00]
-4	.157 [4.00]
-6	.236 [6.00]

- NOTES:
1. REPRESENTS A CRITICAL DIMENSION.
 2. MEASURE WHERE STIFFENER AND CABLE ARE ATTACHED.
 3. MEASURED ALONG LENGTH OF CABLE, EXCEPT WHERE STIFFENER IS ATTACHED TO CABLE.
 4. NOTE DELETED.
 5. STIFFENER IS TRIMMED TO CORRECT WIDTH.
 6. HAND BUILT PARTS USE A BLUE STIFFENER., MACHINE BUILT PARTS USE A BLACK STIFFENER.

UNLESS OTHERWISE SPECIFIED, DIMENSIONS ARE IN INCHES. TOLERANCES ARE:
DECIMALS ANGLES
.XX: ±.01 [.25] 2°
.XXX: ±.005 [.13]
.XXXX: ±.0020 [.050]

PROPRIETARY NOTE
THIS DOCUMENT CONTAINS INFORMATION CONFIDENTIAL AND PROPRIETARY TO SAMTEC, INC. AND SHALL NOT BE REPRODUCED OR TRANSFERRED TO OTHER DOCUMENTS OR DISCLOSED TO OTHERS OR USED FOR ANY PURPOSE OTHER THAN THAT WHICH IT WAS OBTAINED WITHOUT THE EXPRESSED WRITTEN CONSENT OF SAMTEC, INC.

520 PARK EAST BLVD, NEW ALBANY, IN 47150
PHONE: 812-944-6733 FAX: 812-948-5047
e-Mail: info@SAMTEC.com code: 55322

DO NOT SCALE DRAWING SHEET SCALE: 4:1

MATERIAL: CONDUCTORS: TIN PLATED COPPER
SURFACE FINISH EITHER BRIGHT ACID TIN (99.9% SN)
OR MATTE TIN (95.5% SN, 3.5% AG, 1% CU)
INSULATION: POLYESTER
STIFFENER: POLYESTER

F:\DWG\MISC\MKTG\FJ-XX-X-XX-X-MKT.SLDDRW

DESCRIPTION:
.03937 [1.0000] FLEX CABLE JUMPER

DWG. NO.
FJ-XX-X-XX-X

BY: KEVIN B 3/29/99 SHEET 1 OF 2

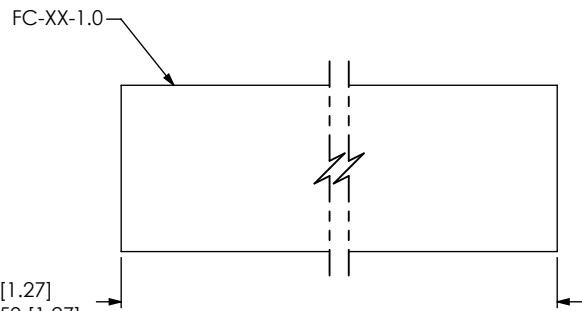

FOR -S: ("XX" LENGTH + .591 [15.16]) ±.050 [1.27]
 FOR -D & -R: ("XX" LENGTH + 1.181 [30.00]) ±.050 [1.27]

IN-PROCESS 1

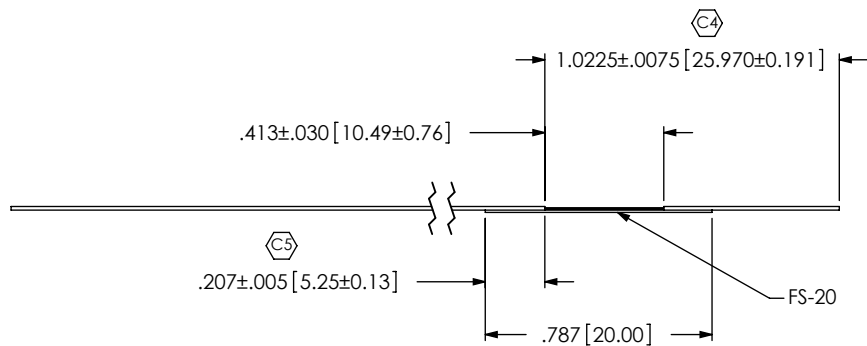
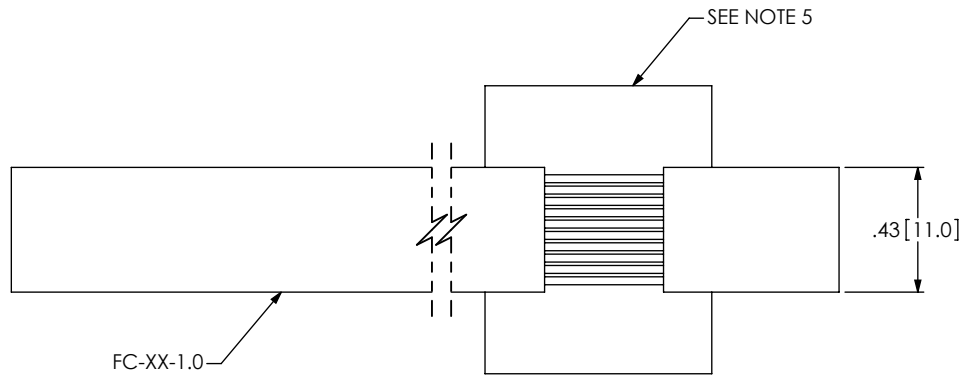

IN-PROCESS 2
 (TYP ON BOTH ENDS FOR -D & -R STYLES)

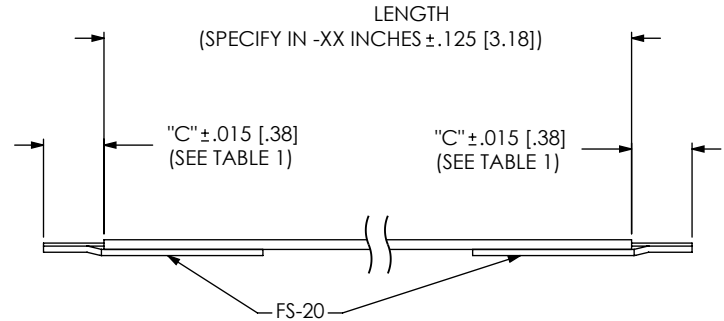

FIG. 2

-D: DOUBLE ENDED
 (SAME AS FIG. 1, UNLESS STATED)

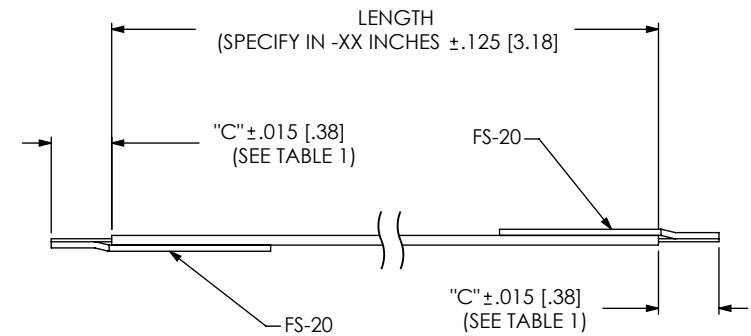

FIG 3

-R: REVERSE STIFFENER
 (SAME AS FIG 1, UNLESS STATED)

PROPRIETARY NOTE
 THIS DOCUMENT CONTAINS INFORMATION
 CONFIDENTIAL AND PROPRIETARY TO
 SAMTEC, INC. AND SHALL NOT BE REPRODUCED
 OR TRANSFERRED TO OTHER DOCUMENTS OR
 DISCLOSED TO OTHERS OR USED FOR ANY
 PURPOSE OTHER THAN THAT WHICH IT WAS
 OBTAINED WITHOUT THE EXPRESSED WRITTEN
 CONSENT OF SAMTEC, INC.

DO NOT SCALE DRAWING

SHEET SCALE: 3:1



520 PARK EAST BLVD, NEW ALBANY, IN 47150
 PHONE: 812-944-6733 FAX: 812-948-5047
 e-Mail: info@SAMTEC.com code: 55322

DESCRIPTION:
 .03937 [1.0000] FLEX CABLE JUMPER

DWG. NO.
 FJ-XX-X-XX-X

BY: KEVIN B 3/29/99 SHEET 2 OF 2