

REV BP

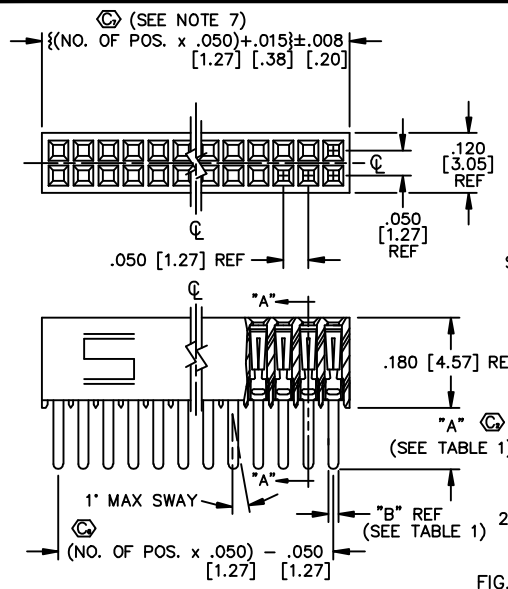

FIG. 1
-X1: THROUGH HOLE

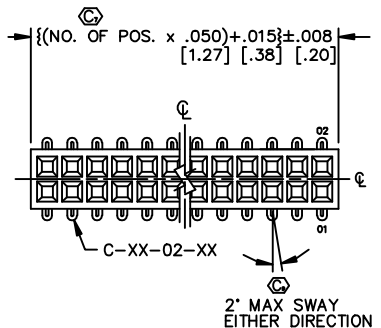
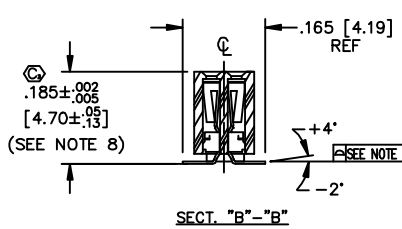
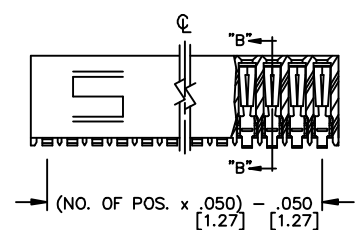

FIG. 2
-X2: SURFACE MOUNT
DIFFERENT AS SHOWN,
OTHERWISE SAME AS FIG. 1.



SECT. "B"- "B"

UNLESS OTHERWISE NOTED TOLERANCES ARE:
 ONE PLACE DECIMALS ±.1 [.3] THREE PLACE DECIMALS ±.005 [.13] ANGLES ± 2°
 TWO PLACE DECIMALS ±.01 [.3] FOUR PLACE DECIMALS ±.0020 [.051]

TABLE 1

SUFFIX	TAIL LENGTH "A"	TAIL WIDTH "B"
-X1	.120 [3.05]	.020 [.51]
-X3	.075 [1.91]	.016 [.41]

SFMC-1XX-XX-XX-D-XX

- NO. OF POSITIONS
 ALL POSITIONS AVAILABLE
 -02 THRU -30
 USE BODY: (SFMC-50-D)
- LEAD STYLE
- 01: THROUGH HOLE (SEE FIGURE 1)
USE CONTACT: (C-44-01-XX)
 - 02: SURFACE MOUNT (SEE FIGURE 2)
USE CONTACT: (C-44-02-XX)
 - 03: STRAIGHT MODIFIED (SEE FIGURE 1)
USE CONTACT: (C-44-03-XX)
 - L1: THROUGH HOLE (LOW INSERTION) (SEE FIGURE 1)
USE CONTACT: (C-81-01-XX)
 - L2: SURFACE MOUNT (LOW INSERTION) (SEE FIGURE 2)
USE CONTACT: (C-81-02-XX)
 - L3: STRAIGHT MODIFIED (LOW INSERTION) (SEE FIGURE 1)
USE CONTACT: (C-81-03-XX)
 - T1: THROUGH HOLE (PHOS BRONZE) (SEE FIGURE 1)
USE CONTACT: (C-119-01-XX)
 - T2: SURFACE MOUNT (PHOS BRONZE) (SEE FIGURE 2)
USE CONTACT: (C-119-02-XX)

- OPTIONS
 (LEAVE BLANK FOR STANDARD)
 -P: PICK AND PLACE PAD (SEE FIGURE 3, SHT 2)
 USE PPP-02 (5 POSITIONS MINIMUM)
 -TR: TAPE & REEL (SEE FIG 4, SHT 2)
 -K: POLYAMIDE FILM PAD (.005 [.13]
 THICKNESS WITH SILICONE ADHESIVE)
 (SEE FIG 4) (USE K-500-300)
 (4 POS MIN)
- BODY SPECIFICATION
 -D: DOUBLE ROW
- PLATING SPECIFICATION
 -S: SELECTIVE, 30 Au / 50 NI MIN ON CONTACT, MATTE TIN TAIL
 -F: FLASH SELECTIVE, 3 Au / 50 NI MIN ON CONTACT, MATTE TIN TAIL
 -H: HEAVY GOLD, 30 Au / 50 NI MIN ON CONTACT, 3 Au / 50 NI MIN ON TAIL
 (ONLY AVAILABLE ON -02, -L2, & -T2 LEAD STYLES)
 -FM: FLASH SELECTIVE, 3 Au / 50 NI MIN ON CONTACT, MATTE TIN TAIL
 -SM: SELECTIVE, 30 Au / 50 NI MIN ON CONTACT, MATTE TIN TAIL
 -L: LIGHT SELECTIVE, 10 Au / 50 NI MIN ON CONTACT, MATTE TIN TAIL

TABLE 2 (SEE NOTE 6)

LEAD STYLE & OPTION	PACKAGING TUBE	PLUG
-X1, -X3, -X3-R	PT-1-24-15-09	TP-24-02
-X2	PT-1-24-14-09	TP-24-02
-X2-K	PT-1-24-14-09	TP-24-02
-X2-P	PT-1-24-01-38	TP-24
-X1-K	PT-1-24-15-09	TP-24-02
-X1-P, -X3-P	PT-1-24-01-09	TP-24

- NOTES:
1. MIN. PUSHOUT FORCE: 5 lb.
 2. COPLANARITY: .004 [.10] = POS 02 THRU 26
.006 [.16] = POS 27 THRU 30
 3. (C) REPRESENTS CRITICAL DIMENSION.
 4. USE SFMC-50-D BODY.
 5. NOTE DELETED.
 6. PACKAGE ONLY POSITIONS -04 THRU -30 IN TUBES;
LAYER PACKAGE POSITIONS -02 THRU -03.
 7. CUT FLASH TO BE .010 MAX WITH NO FLASH EXTENDING BELOW
LEADS OR IN HOLES OF BODY.
 8. MAX HEIGHT VARIATION BETWEEN ANY TWO PINS TO BE .005 [0.05].
 9. PINS CAN BE ORIENTED IN ANY DIRECTION; BOTH ROWS MUST FACE SAME WAY.

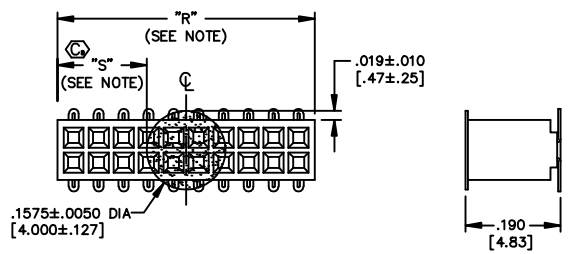

FIGURE 4
-K: POLYAMIDE FILM PAD
(4 POS MIN)
NOTE: "R" = USED MEASURED DIMENSION (REF)
"S" = {"R" - .1575 [4.00]}/2 ±.020 [.51]

PROPRIETARY NOTE
 THIS DOCUMENT CONTAINS INFORMATION
 CONFIDENTIAL AND PROPRIETARY TO
 SAMTEC INC. AND SHALL NOT BE
 REPRODUCED OR TRANSMITTED TO
 OTHER DOCUMENTS OR DISCLOSED TO
 OTHERS OR USED FOR ANY PURPOSE
 OTHER THAN THAT FOR WHICH IT WAS
 OBTAINED WITHOUT THE EXPRESSED
 WRITTEN CONSENT OF SAMTEC INC.

MATERIAL:
 BODY:
 LCP, UL 94 VO
 COLOR: BLACK

CONTACTS:
 C-44 & C-66:
 #25 BeCu, 1/2 HARD
 AGE HARDENED
 C-119
 PHOS BRONZE 521

samtec

520 PARK EAST BLVD. NEW ALBANY, INDIANA 47150
 PHONE (812) 944-6733 P.O. BOX 1147
 CODE 55322

MADE BY:
 BRATCHER 10-5-94

EXISPROD\ASSEMBLY\050
 SFMC-ASM

SFMC-1XX-XX-XX-D-XX
 SHEET 1 OF 2

REV BP

DIMENSIONS ARE IN INCHES		UNLESS OTHERWISE NOTED	TOLERANCES ARE:	TITLE: .050 X .050	DWG NO:
ONE PLACE DECIMALS ± .1 [3]	THREE PLACE DECIMALS ± .005 [.13]	ANGLES	± 2°	CUTTABLE SOCKET STRIP	SFMC-1XX-XX-XX-D-XX
TWO PLACE DECIMALS ± .01 [.3]	FOUR PLACE DECIMALS ± .0020 [.051]			DOUBLE ROW ASSEMBLY	SHEET 2 OF 2

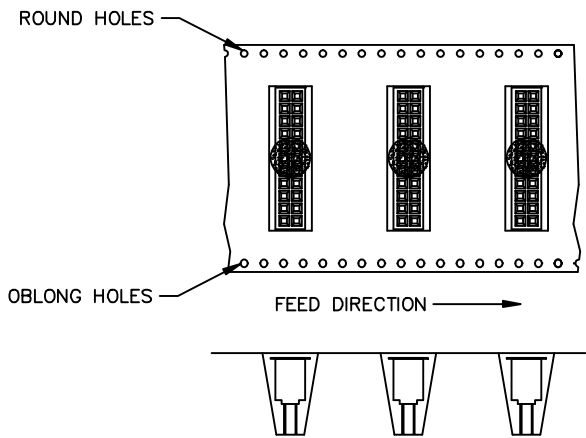

-TR TAPE AND REEL THROUGH HOLE
SCALE: .5x

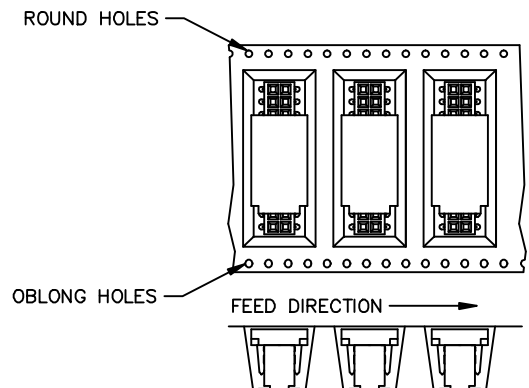
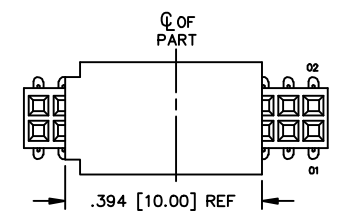

FIG. 4
-TR TAPE AND REEL SURFACE MOUNT
SCALE: .5x

PROPRIETARY NOTE
THIS DOCUMENT CONTAINS INFORMATION CONFIDENTIAL AND PROPRIETARY TO SAMTEC INC. AND SHALL NOT BE REPRODUCED OR TRANSMITTED TO OTHER DOCUMENTS OR DISCLOSED TO OTHERS OR USED FOR ANY PURPOSE OTHER THAN THAT FOR WHICH IT WAS OBTAINED WITHOUT THE EXPRESSED WRITTEN CONSENT OF SAMTEC INC.

POS	"A"
ODD	$\{(No\ OF\ POS\ x\ .050\ [1.27]) / 2\} - .1895\ [4.813]$
EVEN	$\{(No\ OF\ POS\ x\ .050\ [1.27]) / 2\} - .2145\ [5.448]$



5 POSITION MINIMUM
FIGURE 3
-P OPTION
(PAD TO BE POSITIONED AS SHOWN)

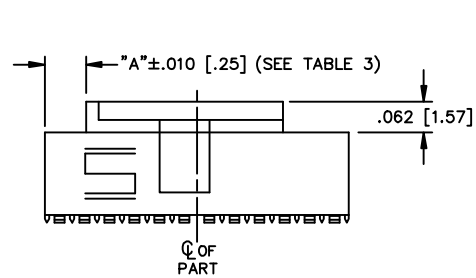

EXISPROD\ASSEMBLY\050
SFMCASM2

samtec

520 PARK EAST BLVD. NEW ALBANY, INDIANA 47150
PHONE (812) 944-6733 P.O. BOX 1147
CODE 55322

MADE BY: BRATCHER 10-5-94

SFMC-1XX-XX-XX-D-XX
SHEET 2 OF 2