

-----Original Message-----

From: Richard Cornell [<mailto:Richard.Cornell@samtec.com>]

Sent: Wednesday, March 04, 2009 7:15 AM

To: CustEN

Subject: Samtec Engineering Change Notification - Drawings Attached

<<Cad.zip>> This is to notify you of a packaging tube change, to a new tube for better fit for the part.

ECN Number: 105714

Part #: SQT-1XX-XX-X-X-XXX-XX

Date of Change: 03/02/09ECN Changes:

SHT 2, PACKAGING VIEW, TABLE 2: CHGTUBE FOR LEAD STYLE -03-6 FROM "PT-1-24-04-56" TO "PT-1-24-01-08"; ADD TUBE VIEW FOR STYLE -03-06.

For inquiries concerning this notification please contact the Customer Service ECN group at customerserviceECN@samtec.com

PROPRIETARY NOTE:

The enclosed documents contain information confidential and proprietary to Samtec, Inc. and shall not be reproduced or transferred to other documents or disclosed to others without the expressed written consent of Samtec, Inc.

DIMENSIONS ARE IN INCHES UNLESS OTHERWISE NOTED		TOLERANCES ARE:
ONE PLACE DECIMALS ± .1[2.5]	THREE PLACE DECIMALS ± .005[.127]	ANGLES ± 2°
TWO PLACE DECIMALS ± .01[.25]	FOUR PLACE DECIMALS ± .0020[.051]	

TITLE: 2MM SOCKET STRIP ASSEMBLY

DWG NO: SQT-1XX-XX-X-X-XXX-XX
SHEET 1 OF 2

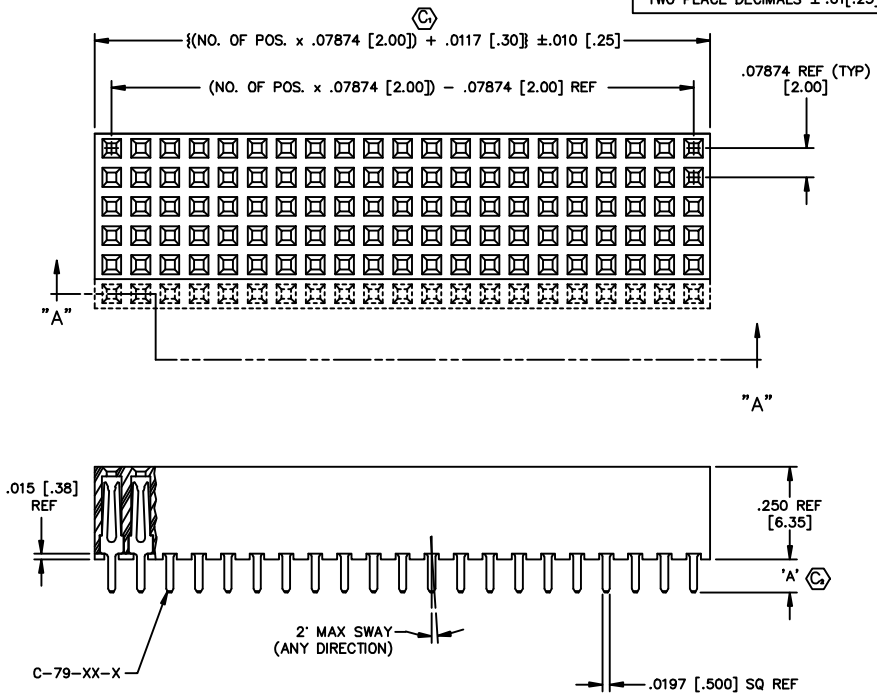

SQT-1XX-XX-X-X-XXX-XX

POSITION SPECIFICATION
-02 THRU -50 (PER ROW)

LEAD STYLE SPEC
SEE TABLE 1

PLATING SPECIFICATION
-F: FLASH SELECTIVE GOLD
-L: LIGHT SELECTIVE GOLD
-G: GOLD
-S: SELECTIVE GOLD
-H: HEAVY GOLD

OPTION
** -MW: METAL WASHER (SEE FIG. 3) (AVAILABLE ON LEAD STYLES -01 & -03 ONLY) (SHT. 2)

POLARIZATION OPTION
-XXX INDICATES POSITION- SEE FIG. 2 (USE PK-07-N)

ROW SPECIFICATION
-5: FIVE ROW (USE SQT-62-5)
-6: SIX ROW (USE SQT-62-6)

** -MW OPTION, DO NOT DESIGN IN. SAMTEC WILL ONLY SUPPORT EXISTING BUSINESS 2/06/02.

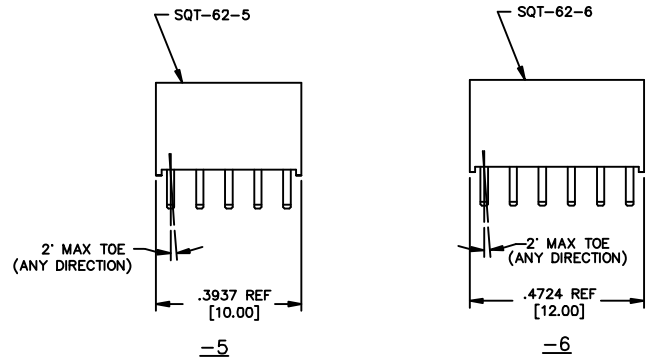

- NOTE:
1. MINIMUM CONTACT RETENTION: .5 lb PER PIN.
 2. CUT FLASH TO BE .020 [.50] MAX.
 3. TOE TO BE 2' MAX.
 4. HEIGHT VARIANCE, PIN TO PIN: .005 [.13] MAX.
 5. Ⓢ REPRESENTS A CRITICAL DIMENSION.
 6. STOCK 62 POSITION ASSEMBLY, -01 LEAD STYLE ONLY. TO BE CUT TO POSITION FOR CUSTOMER.

FIG. 1

TABLE 1

LEAD STYLE	'A'	CONTACT
-01	.090 [2.29]	C-79-01-X
-02	.600 [15.24]	C-79-02-X
-03	.208 [5.28]	C-79-53-X

DO NOT SCALE FROM THIS PRINT



FIG. 2
POLARIZATION OPTION LOCATION
INSERT PK-07 INTO SPECIFIED POSITION AND BREAK OFF TAB

PROPRIETARY NOTE
THIS DOCUMENT CONTAINS INFORMATION CONFIDENTIAL AND PROPRIETARY TO SAMTEC INC. AND SHALL NOT BE REPRODUCED OR TRANSMITTED TO OTHER DOCUMENTS OR DISCLOSED TO OTHERS OR USED FOR ANY PURPOSE OTHER THAN THAT FOR WHICH IT WAS OBTAINED WITHOUT THE EXPRESSED WRITTEN CONSENT OF SAMTEC INC.

MATERIAL:
INSULATOR:
LIQUID CRYSTAL POLYMER
COLOR: BLACK

CONTACT:
PHOSPHOR BRONZE

samtec

520 PARK EAST BLVD. NEW ALBANY, INDIANA 47150
PHONE (812) 944-6733 P.O. BOX 1147
CODE 55322

MADE BY:
BRATCHER 7-24-95

SQT-1XX-XX-X-X-XXX-XX
SHEET 1 OF 2

REV. M

UNLESS OTHERWISE NOTED TOLERANCES ARE:
 DIMENSIONS ARE IN INCHES
 ONE PLACE DECIMALS ± .1[2.5] THREE PLACE DECIMALS ± .005[.127] ANGLES ± 2°
 TWO PLACE DECIMALS ± .01[.25] FOUR PLACE DECIMALS ± .0020[.051]

TITLE:
 2MM SOCKET
 STRIP ASSEMBLY

DWG NO:
 SQT-1XX-XX-X-X-XXX-XX
 SHEET 2 OF 2

PACKAGING VIEW FOR 5 ROW

NOTE:
 THESE VIEWS ARE FOR PLUG ORIENTATION.

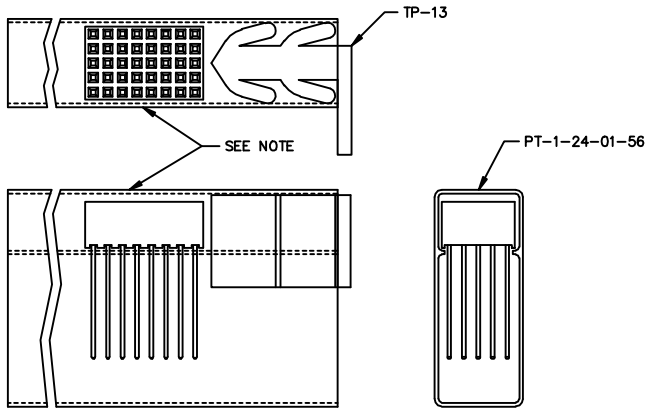
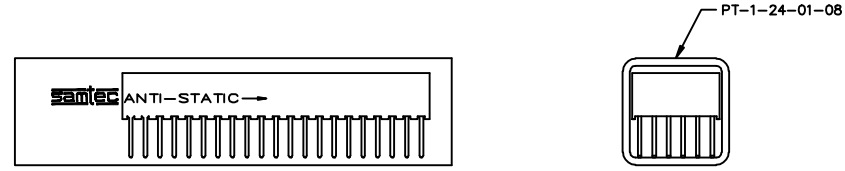

TABLE 2		
LEAD STYLE	PACKAGING TUBE	PLUG
-03-5	PT-1-24-01-08	TP-13
-02-5	PT-1-24-01-56	TP-31
-01-5, -02-5, -03-5	-02 THRU -14	LAYER PACKAGED
-01-6	PT-1-24-01-52	TP-07
-02-6	PT-1-24-03-28	TP-13
-03-6	PT-1-24-01-08	TP-13
-01-5	PT-1-24-09F-109	TP-07



PACKAGING VIEW FOR LEAD STYLE -03 6 ROW

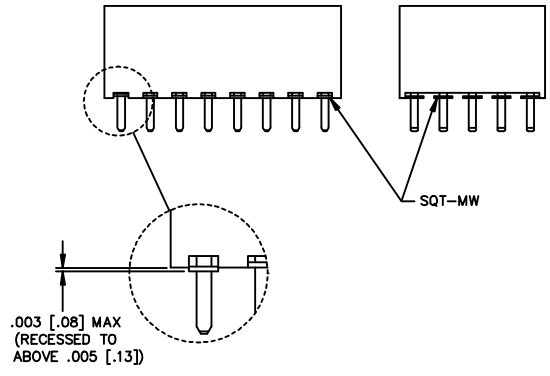

FIG. 3
 -MW: METAL WASHER
 (ONE PER POSITION)
 (AVAILABLE ON LEAD STYLES
 -01 & -03 ONLY)

** -MW OPTION, DO NOT DESIGN IN. SAMTEC WILL ONLY SUPPORT EXISTING BUSINESS 2/06/02.

DO NOT SCALE FROM THIS PRINT

PROPRIETARY NOTE
 THIS DOCUMENT CONTAINS INFORMATION CONFIDENTIAL AND PROPRIETARY TO SAMTEC INC. AND SHALL NOT BE REPRODUCED OR TRANSFERRED TO OTHER DOCUMENTS OR DISCLOSED TO OTHERS OR USED FOR ANY PURPOSE OTHER THAN THAT FOR WHICH IT WAS OBTAINED WITHOUT THE EXPRESSED WRITTEN CONSENT OF SAMTEC INC.

EXISPROD ASSEMBLY\2MM SQT\MKT2

samtec

520 PARK EAST BLVD. NEW ALBANY, INDIANA 47150
 PHONE (812) 944-6733 P.O. BOX 1147
 CODE 55322

MADE BY: BRATCHER 7-24-95

SQT-1XX-XX-X-X-XXX-XX
 SHEET 2 OF 2

PLOT SCALE: 1=.2