

DO NOT SCALE FROM THIS PRINT

TABLE 1

LEAD STYLE	TERMINAL	MAX "A" ("B" IS .000 [.00] MIN)	"C" OVERALL PIN LENGTH
-02	T-1S13-02-XXX-2	.309 [7.85]	.377 [9.6]
-03	T-1S13-03-XXX-2	.467 [11.86]	.535 [13.6]
-04	T-1S13-06-XXX-2	.487 [12.37]	.555 [14.1]
-06	T-1S13-10-XXX-2	.605 [15.37]	.673 [17.1]
-07	T-1S13-11-XXX-2	.683 [17.35]	.751 [19.1]
-09	T-1S13-13-XXX-2	.388 [9.86]	.456 [11.6]

NOTES:

- MAX. PIN ROTATION IN BODY: 2°
- PUSHOUT FORCE SHALL BE 1 LB MIN.
- Ⓢ REPRESENTS A CRITICAL DIMENSION
- ALL DIMENSIONS IN BRACKETS [ ] TO BE MILLIMETERS.
- HEIGHT VARIATION BETWEEN ANY TWO PINS SHALL BE .010 MAX
- TUBE POSITIONS -04 THROUGH -36 ONLY; BULK PACKAGE -02 & -03. TUBE PLUG MUST BE ALLIGNED WITH INSULATOR. (SEE DETAIL ON PAGE 2)
- MOLDED OR STAKED ALIGNMENT PIN AT SAMTEC'S DISCRETION.
- SPACE OPTION FROM .170 TO .209 REQUIRES AN ADDITIONAL REPRESS.
- NOTE DELETED.
- M OPTION AVAILABLE ON -D ROW ONLY. -P OPTION AVAILABLE ON POSITIONS 4-36 ONLY. -P OPTION AVAILABLE ON 4-36 POSITION ONLY.
- DUE TO THE HIGH AMOUNT OF INSERTION FORCE NEEDED, THE -LC OPTION IS NOT COMPATIBLE WITH AUTO PLACEMENT. SAMTEC RECOMMENDS MANUAL PLACEMENT FOR ALL ASSEMBLIES WITH THE -LC OPTION.
- S-A FOR EXISTING BUSINESS ONLY, NEW DESIGNS WILL BE AN SP.
- MAX CUT FLASH: .020 [0.51]
- ORDERS WILL BE PACKAGED ACCORDING TO THE SAMTEC PACKAGING EFFICIENCY STANDARDS (SPES) FOUND ON WWW.SAMTEC.COM
- ATTACH LABEL TO EACH REEL

TW-XX-XX-XXX-X-XXX-SM-XXX-XX-X-XX

**PACKAGING**  
 -BLANK: TUBES (SEE NOTE 6)  
 -TR: TAPE & REEL (SEE NOTE 14 & 15)  
 (-07 LEAD STYLE NOT AVAILABLE IN T & R)  
 (SEE SHEET 3 FOR -S-TR OPTION ORIENTATION VIEW)  
 (.475 MAX "A" WHEN COMBINED WITH -P OPTION)  
 -FR: FULL REEL QTY TAPE & REEL (SEE NOTE 14 & 15)  
 (-07 LEAD STYLE NOT AVAILABLE IN T & R)  
 (SEE SHEET 3 FOR -S-TR OPTION ORIENTATION VIEW)  
 (.475 MAX "A" WHEN COMBINED WITH -P OPTION)

**PICK & PLACE OPTION**  
 -P: PICK & PLACE PAD (SEE NOTE 10)  
 (-D ROW: USE PPP-10)  
 (-S ROW: USE PPP-11)  
 NOTE: "B" = .075 [1.91] MIN FOR THIS OPTION (SEE FIG 6)  
 -M: PICK & PLACE PAD (SEE NOTE 10)  
 (-D ROW: USE PPP-10)  
 NOTE: "B" MUST BE .075 OR GREATER FOR THIS OPTION.  
 (SEE FIG 5)

**OPTION 1**  
 -LC: LOCKING CLIP (SEE FIG 2, SHEET 2)(SEE NOTE 11)  
 (-D ROW: USE 2TS-XX-D)  
 (-S ROW: USE 2TS-XX-SV)  
 (.190 MIN BOARD SPACE)  
 \*-A: MOLDED ALIGNMENT PIN (SEE FIG 3, SHEET 2 & NOTE 7)  
 (AVAILABLE IN 2-36 POSITIONS)  
 (2 POSITIONS WILL ONLY HAVE ONE ALIGNMENT PIN)  
 (-D ROW: USE 2TS-XX-DV-A)  
 (-S ROW: USE 2TS-XX-SV-A)  
 (\*=SEE NOTE 12)  
 (BOTTOM BODY ONLY, USE TMM-50-X FOR TOP)  
 STAKED ALIGNMENT PIN (SEE FIG 4, SHEET 2 & NOTE 7)  
 (-D ROW ONLY: USE TMM-50-D, 4 POS MIN)  
 (.190 MIN BOARD SPACE FOR BOTH)

**OPTION 2**  
 -XXX: POLARIZED POSITION  
 (SPECIFY OMITTED PIN)

**SURFACE MOUNT**  
**SPACE OPTION**  
 (SEE NOTE 8)  
 XXX="A" (SEE TABLE 1, .170 [4.32] MIN)

**No. OF POSITIONS**  
 EXPRESSED IN # OF POS  
 (-02 THRU -36)  
 "XX"= No Of POS x .07874 [2.00]

**LEAD STYLE**  
 (SEE TABLE 1)

**PLATING**  
 -G: 20µ" GOLD IN CONTACT AREA, 3µ" GOLD ON TAIL  
 (USE T-1S13-XX-G-2)  
 -T: MATTE TIN CONTACT AND TAIL (USE T-1S13-XX-T-2)  
 -S: 30µ" GOLD IN CONTACT AREA, MATTE TIN ON TAIL  
 (USE T-1S13-XX-S-2)  
 -E: 50µ" GOLD IN CONTACT AREA, 3µ" GOLD ON TAIL  
 (USE T-1S13-XX-E-2)  
 -L: 10µ" GOLD IN CONTACT AREA, MATTE TIN ON TAIL  
 (USE T-1S13-XX-L-2)  
 -F: 3µ" GOLD IN CONTACT AREA, MATTE TIN ON TAIL  
 (USE T-1S13-XX-F-2)  
 -P: 2µ" - 5µ" GOLD IN CONTACT AREA, MATTE TIN ON TAIL  
 (USE T-1S13-XX-P-2)  
 -TL: TIN/LEAD (90%/10 +/-5%) CONTACT AND TAIL  
 (USE T-1S13-XX-TL-2)  
 -STL: 30µ" GOLD IN CONTACT AREA, TIN/LEAD (90%/10 +/-5%) TAIL  
 -LTL: 10µ" GOLD IN CONTACT AREA, (90%/10 +/-5%) TAIL  
 (USE T-1S13-XX-LTL-2)  
 -H: 30µ" GOLD IN CONTACT AREA, 3µ" GOLD ON TAIL  
 (USE T-1S13-XX-H-2)  
 -SM: 30µ" GOLD IN CONTACT AREA, MATTE TIN ON TAIL  
 (USE T-1S13-XX-S-2)  
 -TM: MATTE TIN CONTACT AND TAIL (USE T-1S13-XX-T-2)  
 -LM: 10µ" GOLD IN CONTACT AREA, MATTE TIN ON TAIL  
 (USE T-1S13-XX-L-2)  
 -FM: 3µ" GOLD IN CONTACT AREA, MATTE TIN ON TAIL  
 (USE T-1S13-XX-F-2)

**ROW OPTION**  
 -S: SINGLE ROW (USE TMM-50-S)  
 -D: DOUBLE ROW (USE TMM-50-D)

TABLE 2 (SEE NOTE 6)

LEAD STYLE	OPTIONS	TUBE	PLUGS
-02, -04, -07, -09	-D, -D-LC, -D-A	PT-TW001-D-SM	TP-38
-03	-D, -D-LC, -D-A	PT-TW001-D-SM	TP-38
ALL	-S, -S-LC, -S-A	PT-TW002-S-SM	TP-38
-02,-09	-D-A-P, -D-LC-P, -D-P, -D-LC-M, -D-A-M, -D-M	PT-TW001-D-SM	TP-38
-03,-04	-D-A-P, -D-LC-P, -D-P, -D-LC-M, -D-A-M, -D-M	PT-TW001-D-SM	TP-38
-07	-D-A-P, -D-LC-P, -D-P, -D-LC-M, -D-A-M, -D-M	PT-TW001-D-SM	TP-38
-02,-09	-S-LC-P, *-S-A-P	PT-TW002-S-SM	TP-38
-03,-04	-S-LC-P, *-S-A-P, -S-P	PT-TW002-S-SM	TP-38
-07	-S-LC-P, *-S-A-P, -S-P	PT-TW002-S-SM	TP-38
-06	-D-LC	PT-TW001-D-SM	TP-38
-06	NONE, -A, -D	PT-TW001-D-SM	TP-38
-06	-D-A-P, -D-LC-P, -D-P, -D-LC-M, -D-A-M	PT-TW001-D-SM	TP-38
-06	-S-LC-P, -S-A-P, -S-P	PT-TW002-S-SM	TP-38
-06	-D-M	PT-1-24-16-29	TP-38

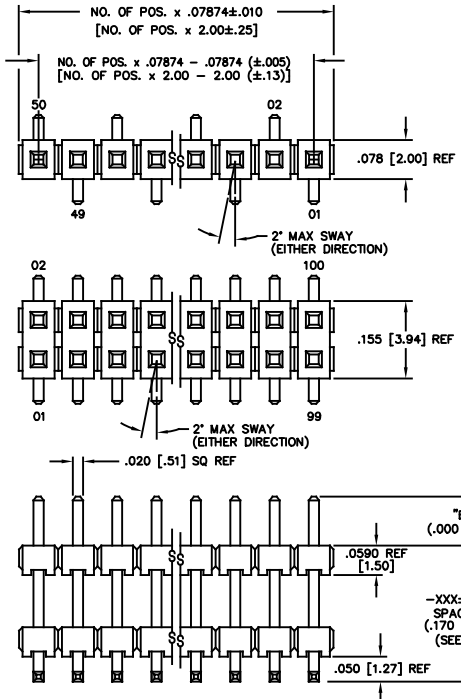
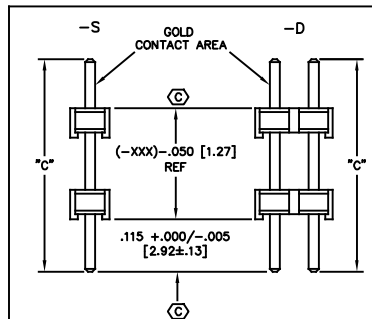

FIG 1



**PATENT NUMBERS**  
 5713755 / 5961339

IN-PROCESS

**\*PROPRIETARY NOTE\***  
 This document contains confidential and proprietary information and is intended for internal use only. It is not to be distributed, copied, or used in any way without the express written consent of Samtec, Inc.

MATERIAL: INSULATOR: LIQUID CRYSTAL POLYMER COLOR: BLACK	TERMINALS: PHOSPHOR BRONZE	DESIGN/ASSEMBLY/DM TW-SM
<b>samtec</b>		
520 PARK EAST BLVD. NEW ALBANY, INDIANA 47150 PHONE (812) 944-6733 P.O. BOX 1147 CODE 55322		
MADE BY: BRYANT 3-8-93		TW-XX-XX-XXX-X-XXX-SM-XXX-XX-X-XX