

DO NOT SCALE FROM THIS PRINT

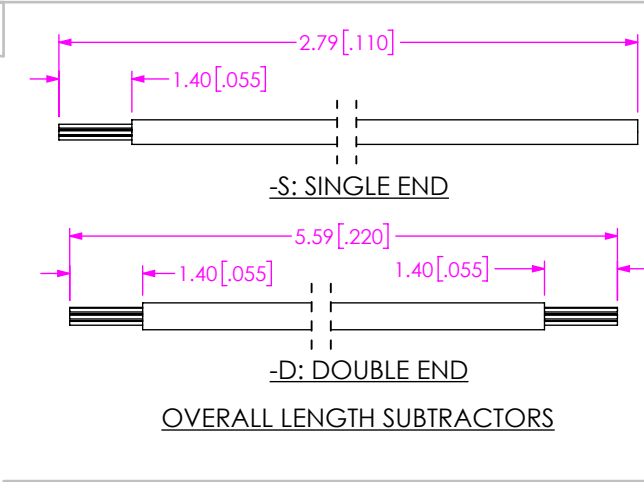

**S1SSX-XX-XXX-XX-XX.XX-X-XXX**

**FEP CABLE OPTION**  
 -T: FEP INSULATION  
 LEAVE BLANK FOR PVC  
 (SEE NOTE 8)

**No OF POSITIONS**  
 -02, -03, -05, -07, -10, -15, -20  
 (PER ROW) AVAILABLE AS STANDARD  
 -02 THRU -20 AVAILABLE AS ASO

**WIRE GAUGE (AWG)**  
 -28, -30

**COLOR CODE**  
 -C: COLOR CODE WIRE  
 (SEE TABLE 3, SHEET 2)  
 LEAVE BLANK FOR STANDARD WIRE  
 (SEE TABLE 1)  
 NOT AVAILABLE FOR TEFLON OPTION,  
 TEFLON CABLE ONLY AVAILABLE IN BLUE

**OPTION**  
**DOUBLE**  
 (MUST BE USED ON -D END OPTION ONLY  
 & APPLIES TO END 2 HOUSING)  
 -NUS: NO LATCH, "N" UP, STRAIGHT  
 -NDS: NO LATCH, "N" DOWN, STRAIGHT

**END OPTION**  
 -S: SINGLE END  
 -D: DOUBLE END

**ASSEMBLED LENGTH**  
 (SPECIFY IN INCHES)  
 01.80 IN MINIMUM

**PLATING SPECIFICATION**  
 \*-T: TIN PLATING  
 -GF: 3u" MIN Au/50u" Ni  
 IN CONTACT AND TAIL

\* = EXISTING CUSTOMERS ONLY

**DESIGNED & DIMENSIONED  
 IN MILLIMETERS [INCHES]**

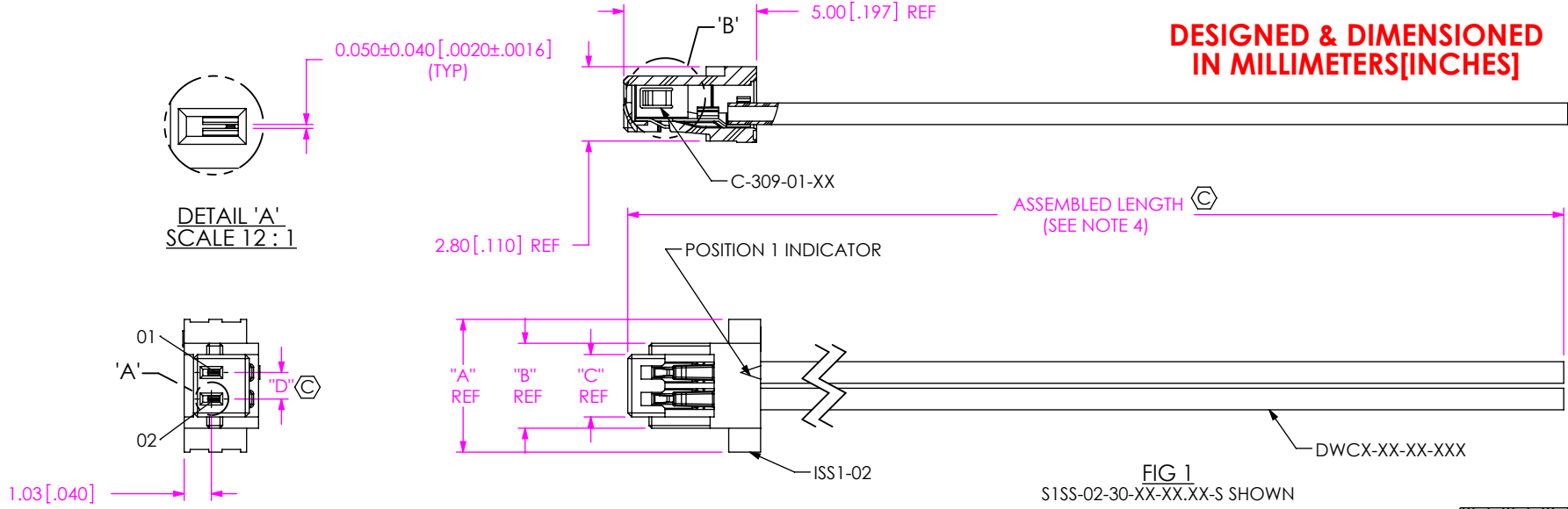

**TABLE 1**

WIRE GAUGE	WIRE PART NUMBER
-28	DWC-28-10-300
-30	DWC-30-10-300
-28	DWCT-28-01-TC
-30	DWCT-30-01-TC

NOTES:

1. Ⓢ REPRESENTS A CRITICAL DIMENSION.
2. MINIMUM PUSHOUT FORCE: SIGNAL: 6.6N[1.5 LB]
3. PARTS TO BE PACKAGED IN BAG.
4. FOR ASSEMBLED LENGTHS LESS THAN 13.00 IN, TOLERANCE SHALL BE ± .125[3.18], FOR OTHER LENGTHS, TOLERANCE SHALL BE ± 2%.
5. REFER TO CRIMP SPECIFICATIONS FOR CRIMP AND STRIP DIMENSIONS, TOLERANCES, TOOLING, AND ITS REQUIREMENTS.
6. CONTACT MUST BE INSERTED UNTIL RETENTION FEATURE LOCKS IN PLACE.
7. ALL FINISHED GOODS ARE TO BE ELECTRICALLY TESTED INCLUDING HI-POT TEST AT 1000 VOLTS DC. AFTER FINAL ELECTRICAL TEST, LABEL EACH ASSEMBLY WITH (1) ET STAMP ON THE BODY.
8. SINGLE ENDED ASSEMBLIES USING THE FEP OPTION ARE FOR CRIMP APPLICATIONS ONLY.

**UNLESS OTHERWISE SPECIFIED, DIMENSIONS ARE IN MILLIMETERS.**

TOLERANCES ARE:

DECIMALS	ANGLES
X.X: ±0.3 [.01]	2°
X.XX: ±0.13 [.005]	
X.XXX: ±0.051 [.0020]	

**PROPRIETARY NOTE**  
 THIS DOCUMENT CONTAINS CONFIDENTIAL AND PROPRIETARY INFORMATION AND ALL DESIGN, MANUFACTURING, REPRODUCTION, USE, PATENT RIGHTS AND SALES RIGHTS ARE EXPRESSLY RESERVED BY SAMTEC, INC. THIS DOCUMENT SHALL NOT BE DISCLOSED, IN WHOLE OR PART, TO ANY UNAUTHORIZED PERSON OR ENTITY NOR REPRODUCED, TRANSFERRED OR INCORPORATED IN ANY OTHER PROJECT IN ANY MANNER WITHOUT THE EXPRESS WRITTEN CONSENT OF SAMTEC, INC.

**MATERIAL:** DO NOT SCALE DRAWING SHEET SCALE: 6:1  
 INSULATOR: PPA UL 94-V0, COLOR: BLACK  
 CONTACT: PHOS BRONZE

**samtec**

520 PARK EAST BLVD, NEW ALBANY, IN 47150  
 PHONE: 812-944-6733 FAX: 812-948-5047  
 e-Mail: info@SAMTEC.com code 53322

DESCRIPTION:  
 1MM CABLE ASSEMBLY

DWG. NO.  
**S1SSX-XX-XXX-XX-XX.XX-X-XXX**

BY: VICKY Z 04/13/2010 SHEET 1 OF 2

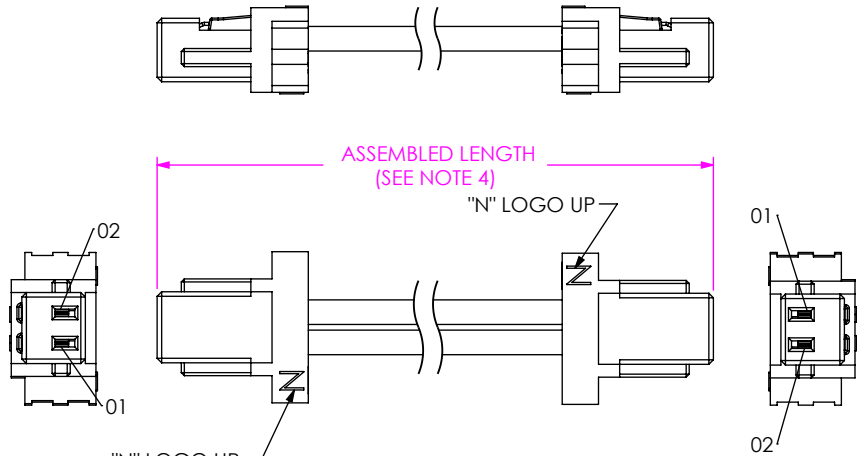

**FIG 2**  
S1SS-02-30-XX-XX.XX-D-NUS SHOWN  
(SAME AS FIG 1, EXCEPT AS SHOWN)

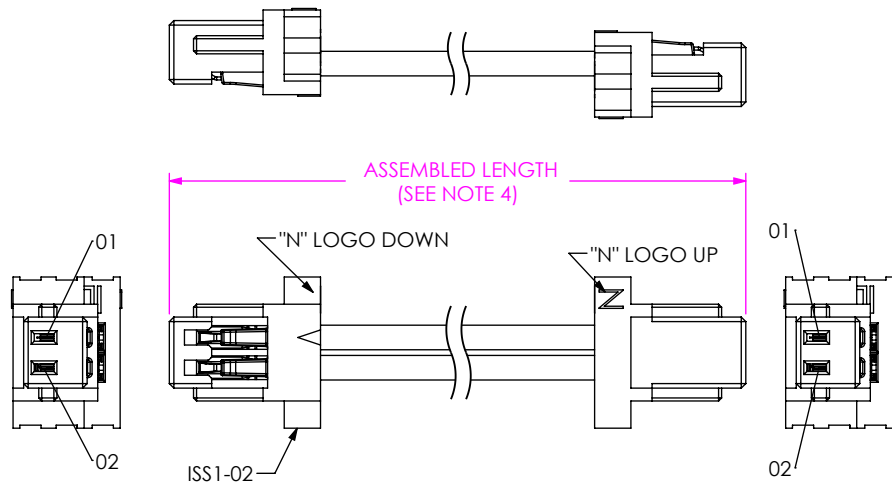

**FIG 3**  
S1SS-02-30-XX-XX.XX-D-NDS SHOWN  
(SAME AS FIG 1, EXCEPT AS SHOWN)

No. OF POS	"A"	"B"	"C"	"D"
-02	5.00 [0.197]	3.200 [0.1260]	2.350 [0.0925]	1.000 [0.0394]
-03	6.00 [0.236]	4.200 [0.1654]	3.350 [0.1319]	2.000 [0.0787]
-04	7.00 [0.276]	5.200 [0.2047]	4.350 [0.1713]	3.000 [0.1181]
-05	8.00 [0.315]	6.200 [0.2441]	5.350 [0.2106]	4.000 [0.1575]
-06	9.00 [0.354]	7.200 [0.2835]	6.350 [0.2500]	5.000 [0.1969]
-07	10.00 [0.394]	8.200 [0.3228]	7.350 [0.2894]	6.000 [0.2362]
-08	11.00 [0.433]	9.200 [0.3622]	8.350 [0.3287]	7.000 [0.2756]
-09	12.00 [0.472]	10.200 [0.4016]	9.350 [0.3681]	8.000 [0.3150]
-10	13.00 [0.512]	11.200 [0.4409]	10.350 [0.4075]	9.000 [0.3543]
-11	14.00 [0.551]	12.200 [0.4803]	11.350 [0.4469]	10.000 [0.3937]
-12	15.00 [0.591]	13.200 [0.5197]	12.350 [0.4862]	11.000 [0.4331]
-13	16.00 [0.630]	14.200 [0.5591]	13.350 [0.5256]	12.000 [0.4724]
-14	17.00 [0.669]	15.200 [0.5984]	14.350 [0.5650]	13.000 [0.5118]
-15	18.00 [0.709]	16.200 [0.6378]	15.350 [0.6043]	14.000 [0.5512]
-16	19.00 [0.748]	17.200 [0.6772]	16.350 [0.6437]	15.000 [0.5906]
-17	20.00 [0.787]	18.200 [0.7165]	17.350 [0.6831]	16.000 [0.6299]
-18	21.00 [0.827]	19.200 [0.7559]	18.350 [0.7224]	17.000 [0.6693]
-19	22.00 [0.866]	20.200 [0.7953]	19.350 [0.7618]	18.000 [0.7087]
-20	23.00 [0.906]	21.200 [0.8346]	20.350 [0.8012]	19.000 [0.7480]

S1SX COLOR CODED WIRE SEQUENCE										
PIN#	COLOR									
	BROWN	RED	ORANGE	YELLOW	GREEN	BLUE	VIOLET	GRAY	WHITE	BLACK
1	2	3	4	5	6	7	8	9	10	
11	12	13	14	15	16	17	18	19	20	
28 AWG WIRE	DWC-28-01-300	DWC-28-02-300	DWC-28-03-300	DWC-28-04-300	DWC-28-05-300	DWC-28-13-300	DWC-28-07-300	DWC-28-08-300	DWC-28-09-300	DWC-28-10-300
30 AWG WIRE	DWC-30-01-300	DWC-30-02-300	DWC-30-03-300	DWC-30-04-300	DWC-30-05-300	DWC-30-13-300	DWC-30-07-300	DWC-30-08-300	DWC-30-09-300	DWC-30-10-300

**PROPRIETARY NOTE**  
THIS DOCUMENT CONTAINS CONFIDENTIAL AND PROPRIETARY INFORMATION AND ALL DESIGN, MANUFACTURING, REPRODUCTION, USE, PATENT RIGHTS AND SALES RIGHTS ARE EXPRESSLY RESERVED BY SAMTEC, INC. THIS DOCUMENT SHALL NOT BE DISCLOSED, IN WHOLE OR PART, TO ANY UNAUTHORIZED PERSON OR ENTITY NOR REPRODUCED, TRANSFERRED OR INCORPORATED IN ANY OTHER PROJECT IN ANY MANNER WITHOUT THE EXPRESS WRITTEN CONSENT OF SAMTEC, INC.

DO NOT SCALE DRAWING

SHEET SCALE: 4:1



520 PARK EAST BLVD, NEW ALBANY, IN 47150  
PHONE: 812-944-6733 FAX: 812-948-5047  
e-Mail info@SAMTEC.com code 55322

DESCRIPTION:  
1MM CABLE ASSEMBLY

DWG. NO.  
**S1SSX-XX-XXX-XX-XX.XX-X-XXX**

BY: VICKY Z 04/13/2010 SHEET 2 OF 2