

DESIGNED & DIMENSIONED  
IN MILLIMETERS[INCHES]

PATENT PENDING

DO NOT  
SCALE FROM  
THIS PRINT

**TABLE 1**

No OF POS	N	N-1
-02	04	03
-03	06	05
-04	08	07
-05	10	09
-06	12	11
-07	14	13
-08	16	15
-09	18	17
-10	20	19
** -11	22	21
** -12	24	23
** -13	26	25
** -14	28	27
** -15	30	29
** -16	32	31
** -17	34	33
** -18	36	35
** -19	38	37
** -20	40	39

(\*\* = NOT RELEASED FOR PRODUCTION)

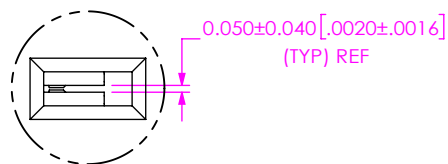

DETAIL 'A'  
SCALE 18 : 1

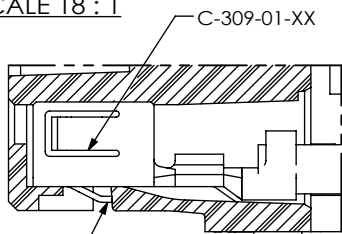

DETAIL 'B'  
SCALE 8 : 1

SEE NOTE 6

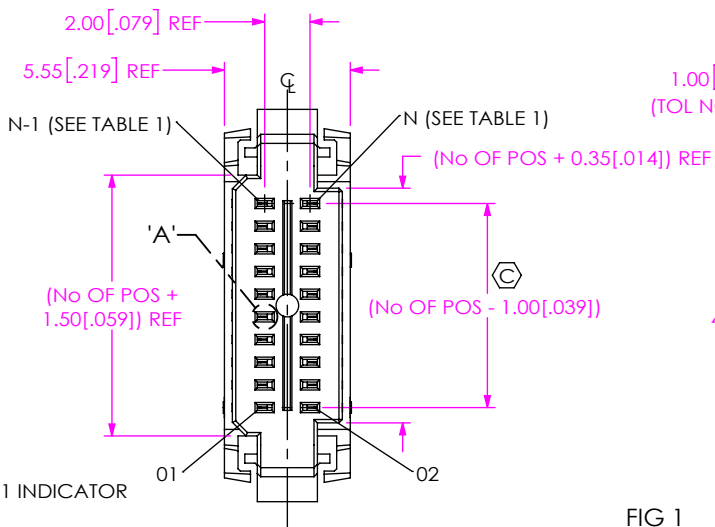
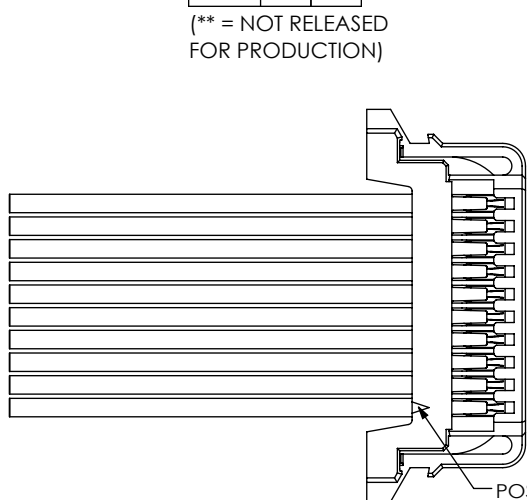

S1SDX-XX-XXX-XX-XX.XX-LX

FEP CABLE OPTION  
-T: FEP INSULATION  
(ONLY AVAILABLE IN 28 AWG)  
LEAVE BLANK FOR PVC  
(SEE NOTE 8)

No OF POSITIONS (PER ROW)  
-02 THRU -10  
\*\*-11 THRU \*\*-20

WIRE GAUGE (AWG)  
-28, -30

COLOR CODE  
-C COLOR CODE WIRE  
(SEE TABLE 4, SHT 2)  
LEAVE BLANK FOR STANDARD WIRE  
(SEE TABLE 2, SHT 2)  
(NOT AVAILABLE WITH S1SDT)

(\*\* = NOT RELEASED FOR PRODUCTION)

PINOUT  
(LEAVE BLANK FOR SINGLE END ASSEMBLY)  
-1: "N" INDICATOR DOWN, CROSSED  
PIN 1 TO PIN 1 (SEE FIG 2, SHT 2)  
-2: "N" INDICATOR DOWN, STRAIGHT  
PIN 1 TO PIN 2 (SEE FIG 3, SHT 2)  
-3: "N" INDICATOR UP, CROSSED  
PIN 1 TO PIN N (SEE FIG 4, SHT 3)  
-4: "N" INDICATOR UP, STRAIGHT  
PIN 1 TO PIN N-1 (SEE FIG 5, SHT 3)

LATCH OPTION  
-L: PLASTIC LATCH

ASSEMBLED LENGTH  
(SPECIFY IN INCHES) 01.80 IN MINIMUM

PLATING SPECIFICATION  
-T: BRIGHT ACID TIN TIN CONTACT AND TAIL  
-GF: 3μ" GOLD CONTACT AND TAIL

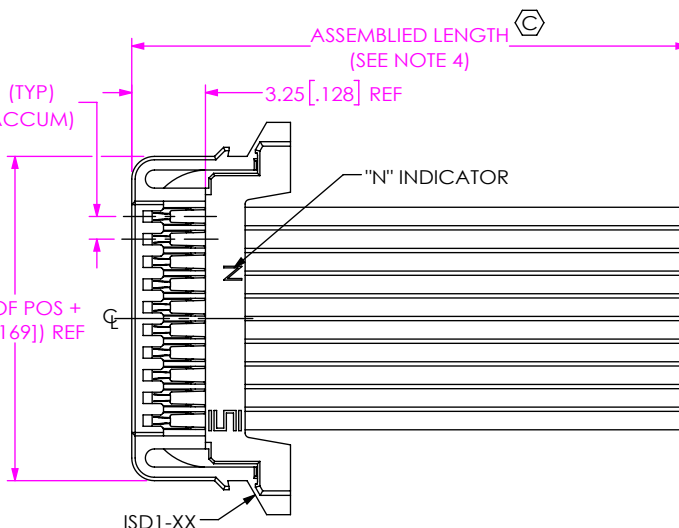
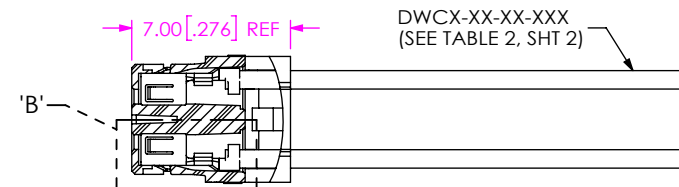

FIG 1

S1SD-10-XXX-XX-XX.XX-L SHOWN

NOTES:

- ⊕ REPRESENTS A CRITICAL DIMENSION.
- MINIMUM PUSHOUT FORCE: SIGNAL: 4.445N[1.0 LB].
- PARTS TO BE PACKAGED IN BAG.
- FOR ASSEMBLED LENGTHS LESS THAN 12.0[305], TOLERANCE SHALL BE ± 3.18[.125], FOR OTHER LENGTHS, TOLERANCE SHALL BE ± 2%.
- REFER TO CRIMP SPECIFICATIONS FOR CRIMP AND STRIP DIMENSIONS, TOLERANCES, TOOLING, AND ITS REQUIREMENTS.
- CONTACT MUST BE INSERTED UNTIL RETENTION FEATURE LOCKS IN PLACE.
- ALL FINISHED GOODS ARE TO BE ELECTRICALLY TESTED INCLUDING HI-POT TEST AT 1000 VOLTS DC. AFTER FINAL ELECTRICAL TEST, LABEL WITH 1 ET STAMP ON THE BODY.
- ASSEMBLIES USING THE FEP OPTION ARE FOR CRIMP APPLICATIONS ONLY.
- REFER TO CRIMP SPECIFICATIONS PRINT FOR STRIP AND CRIMP DIMENSIONS, TOLERANCES, TOOLING, AND ITS REQUIREMENTS.
- CUT LENGTH IS ASSEMBLY LENGTH MINUS OVERALL LENGTH SUBTRACTOR.
- TABLE 3 IS DELETED AND REPLACED WITH EQUATIONS.

UNLESS OTHERWISE SPECIFIED,  
DIMENSIONS ARE IN MILLIMETERS.  
TOLERANCES ARE:  
DECIMALS ANGLES  
X.X: ±0.3 [01] 2°  
X.XX: ±0.13 [005]  
X.XXX: ±0.051 [0020]

PROPRIETARY NOTE  
THIS DOCUMENT CONTAINS CONFIDENTIAL AND PROPRIETARY INFORMATION AND ALL DESIGN, MANUFACTURING, REPRODUCTION, USE, PATENT RIGHTS AND SALES RIGHTS ARE EXPRESSLY RESERVED BY SAMTEC, INC. THIS DOCUMENT SHALL NOT BE DISCLOSED, IN WHOLE OR PART, TO ANY UNAUTHORIZED PERSON OR ENTITY NOR REPRODUCED, TRANSFERRED OR INCORPORATED IN ANY OTHER PROJECT IN ANY MANNER WITHOUT THE EXPRESS WRITTEN CONSENT OF SAMTEC, INC.

MATERIAL: DO NOT SCALE DRAWING SHEET SCALE: 3:1  
INSULATOR: NYLON UL94V-2, COLOR: WHITE  
CONTACT: PHOS BRONZE

F:\DWG\MISC\MKTG\S1SDX-XX-XXX-XX-XX.XX-LX-MKT.SLDDRW



520 PARK EAST BLVD, NEW ALBANY, IN 47150  
PHONE: 812-944-6733 FAX: 812-948-5047  
e-Mail: info@SAMTEC.com code 55322

DESCRIPTION:  
1MM S1SD CABLE ASSEMBLY  
DWG. NO.  
S1SDX-XX-XXX-XX-XX.XX-LX  
BY: VICKY Z 06/22/2013 SHEET 1 OF 3

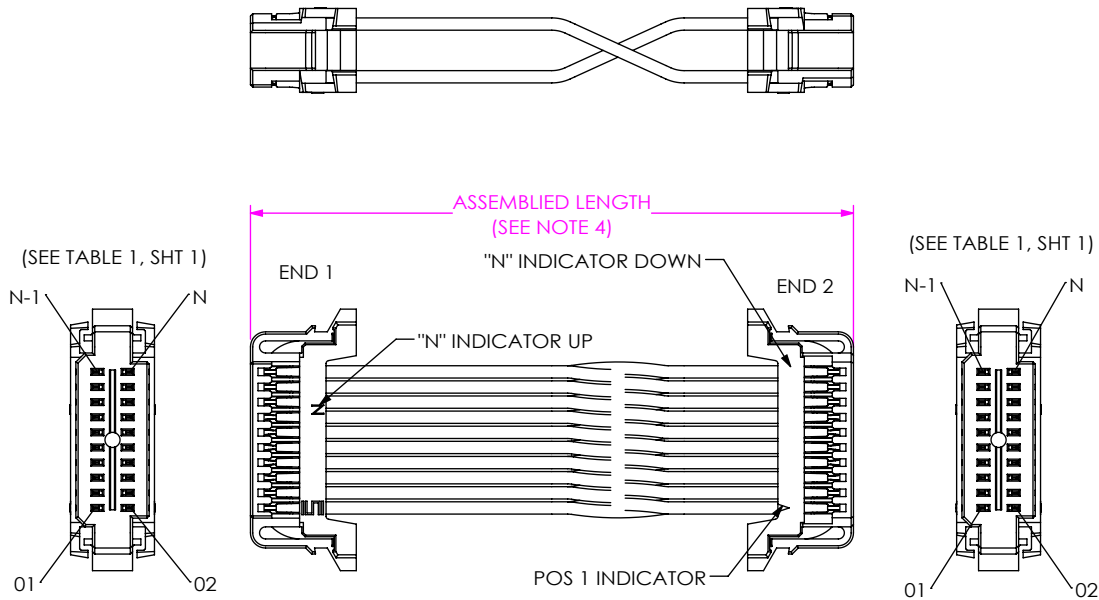

**FIG 2**  
S1SD-10-XXX-XX-XX.XX-L1 SHOWN  
(DIFFERENT AS SHOWN, OTHERWISE SAME AS FIG 1)

TABLE 2		
WIRE GAUGE	INSULATION	WIRE PART NUMBER
-28	PVC	DWC-28-10-300
	FEP	DWCT-28-01-TC
-30	PVC	DWC-30-10-300

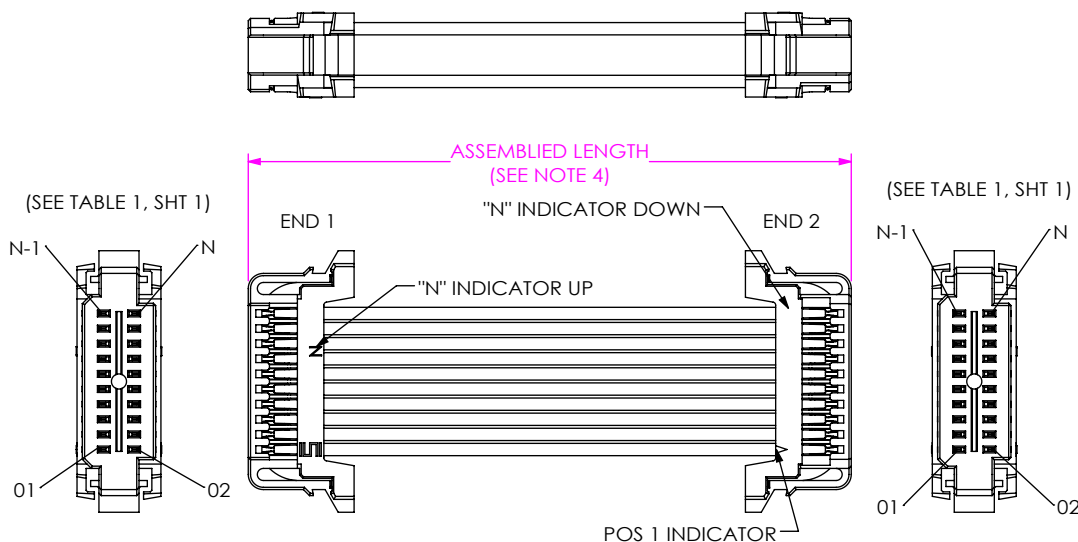

**FIG 3**  
S1SD-10-XXX-XX-XX.XX-L2 SHOWN  
(DIFFERENT AS SHOWN, OTHERWISE SAME AS FIG 1)

TABLE 4										
S1SD COLOR CODED WIRE SEQUENCE										
PIN#	COLOR									
	BROWN	RED	ORANGE	YELLOW	GREEN	BLUE	VIOLET	GRAY	WHITE	BLACK
	1	2	3	4	5	6	7	8	9	10
	11	12	13	14	15	16	17	18	19	20
	21	22	23	24	25	26	27	28	29	30
	31	32	33	34	35	36	37	38	39	40
28 AWG WIRE	DWC-28-01-300	DWC-28-02-300	DWC-28-03-300	DWC-28-04-300	DWC-28-05-300	DWC-28-13-300	DWC-28-07-300	DWC-28-08-300	DWC-28-09-300	DWC-28-10-300
30 AWG WIRE	DWC-30-01-300	DWC-30-02-300	DWC-30-03-300	DWC-30-04-300	DWC-30-05-300	DWC-30-13-300	DWC-30-07-300	DWC-30-08-300	DWC-30-09-300	DWC-30-10-300

**PROPRIETARY NOTE**  
THIS DOCUMENT CONTAINS CONFIDENTIAL AND PROPRIETARY INFORMATION AND ALL DESIGN, MANUFACTURING, REPRODUCTION, USE, PATENT RIGHTS AND SALES RIGHTS ARE EXPRESSLY RESERVED BY SAMTEC, INC. THIS DOCUMENT SHALL NOT BE DISCLOSED, IN WHOLE OR PART, TO ANY UNAUTHORIZED PERSON OR ENTITY NOR REPRODUCED, TRANSFERRED OR INCORPORATED IN ANY OTHER PROJECT IN ANY MANNER WITHOUT THE EXPRESS WRITTEN CONSENT OF SAMTEC, INC.



520 PARK EAST BLVD, NEW ALBANY, IN 47150  
PHONE: 812-944-6733 FAX: 812-948-5047  
e-Mail info@SAMTEC.com code 55322

DO NOT SCALE DRAWING

SHEET SCALE: 2:1

DESCRIPTION:  
1MM S1SD CABLE ASSEMBLY

DWG. NO.  
S1SDX-XX-XXX-XX-XX.XX-LX

BY: VICKY Z 06/22/2013 SHEET 2 OF 3

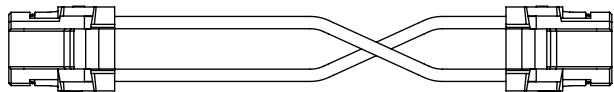

(SEE TABLE 1, SHT 1)

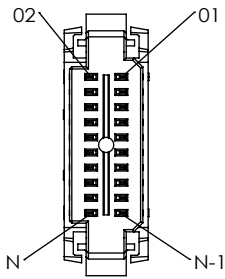
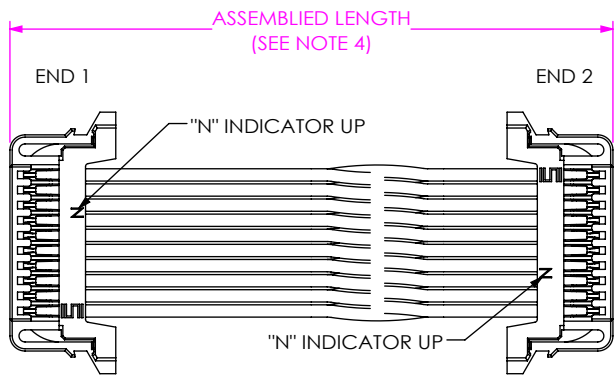
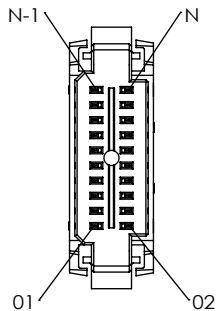

(SEE TABLE 1, SHT 1)

**FIG 4**  
S1SD-10-XXX-XX-XX.XX-L3 SHOWN  
(DIFFERENT AS SHOWN, OTHERWISE SAME AS FIG 1)

CABLE CUT IN-PROCESS

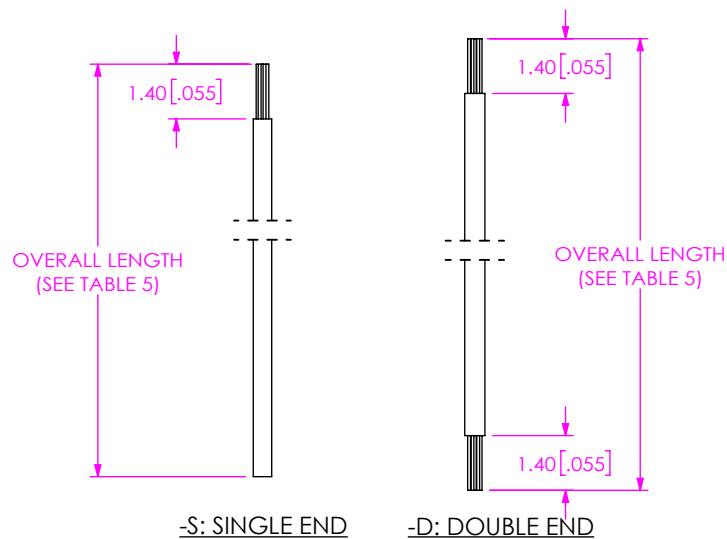

**-S: SINGLE END**      **-D: DOUBLE END**

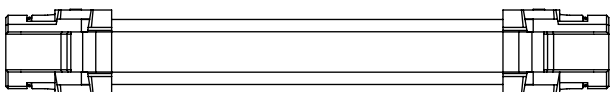

(SEE TABLE 1, SHT 1)

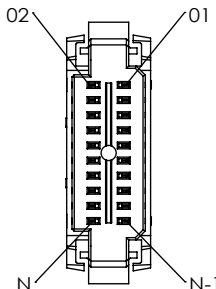
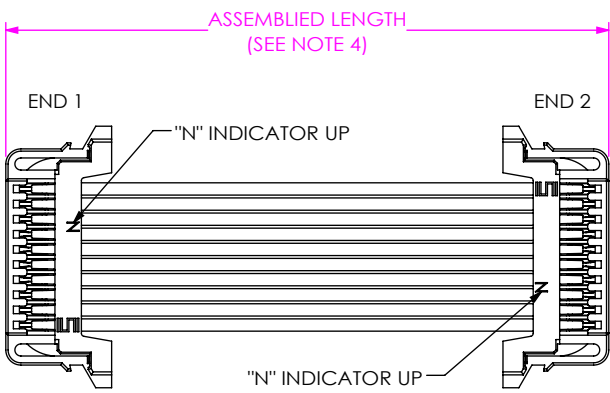
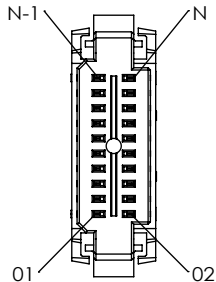

(SEE TABLE 1, SHT 1)

**FIG 5**  
S1SD-10-XXX-XX-XX.XX-L4 SHOWN  
(DIFFERENT AS SHOWN, OTHERWISE SAME AS FIG 1)

TABLE 5 ( OVERALL LENGTH SUBTRACTORS ) (SEE NOTE 10)	
	LENGTH
-S: SINGLE END	2.79 [.110]
-D: DOUBLE END	5.59 [.220]

**PROPRIETARY NOTE**  
THIS DOCUMENT CONTAINS CONFIDENTIAL AND PROPRIETARY INFORMATION AND ALL DESIGN, MANUFACTURING, REPRODUCTION, USE, PATENT RIGHTS AND SALES RIGHTS ARE EXPRESSLY RESERVED BY SAMTEC, INC. THIS DOCUMENT SHALL NOT BE DISCLOSED, IN WHOLE OR PART, TO ANY UNAUTHORIZED PERSON OR ENTITY NOR REPRODUCED, TRANSFERRED OR INCORPORATED IN ANY OTHER PROJECT IN ANY MANNER WITHOUT THE EXPRESS WRITTEN CONSENT OF SAMTEC, INC.



520 PARK EAST BLVD, NEW ALBANY, IN 47150  
PHONE: 812-944-6733 FAX: 812-948-5047  
e-Mail info@SAMTEC.com code 55322

DO NOT SCALE DRAWING

SHEET SCALE: 2:1

DESCRIPTION: 1MM S1SD CABLE ASSEMBLY

DWG. NO. S1SDX-XX-XXX-XX-XX.XX-LX

BY: VICKY Z 06/22/2013 SHEET 3 OF 3