

DO NOT SCALE FROM THIS PRINT

DESIGNED & DIMENSIONED IN MILLIMETERS[INCHES]

LSHM-1XX-XX-X-DH-A-X-X-TR

No OF POSITIONS  
-05, -10, -20, -30, -40, -50

LEAD STYLE  
-01: RIGHT ANGLE ONLY  
-L1: LUBRICATED (SEE TABLE 2)

PLATING SPECIFICATION  
-L: 10µ" LIGHT SELECTIVE GOLD ON CONTACT AREA, MATTE TIN ON TAIL  
-F: 3µ" FLASH SELECTIVE GOLD ON CONTACT AREA, MATTE TIN ON TAIL  
-S: 30µ" FLASH SELECTIVE GOLD ON CONTACT AREA, MATTE TIN ON TAIL

PACKAGING  
-TR: TAPE & REEL (SEE NOTE 6)  
OPTION  
-K: POLYAMIDE FILM (USE K-DOT-.177-.281-.005)  
SHIELD  
-S: WITH SHIELD (NO WT IS TO BE USED)  
-N: WITHOUT SHIELD  
TAIL OPTION  
-DH: RIGHT ANGLE

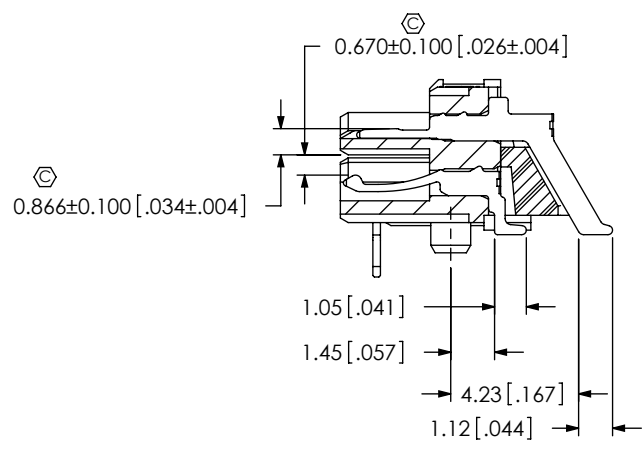
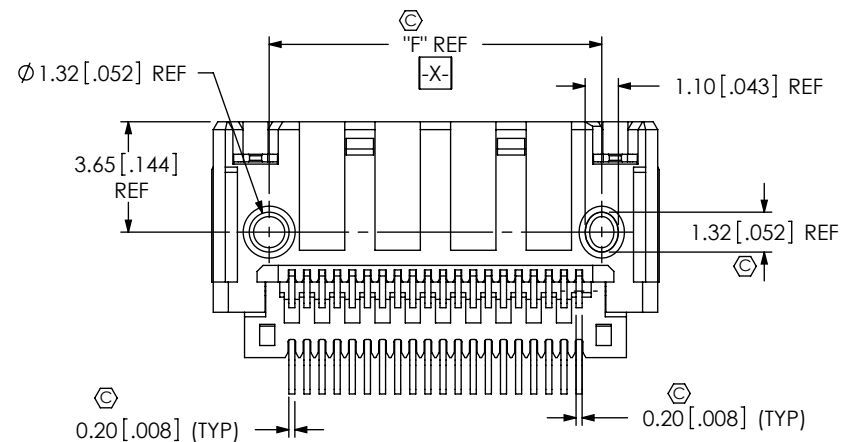
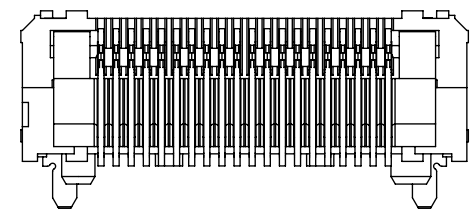
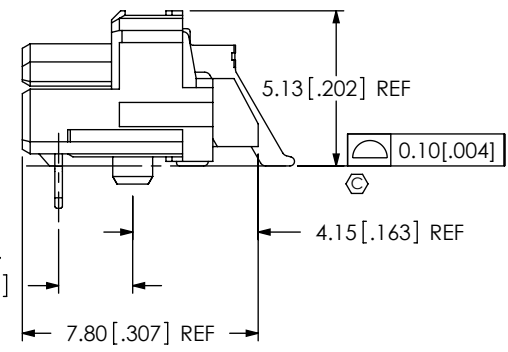
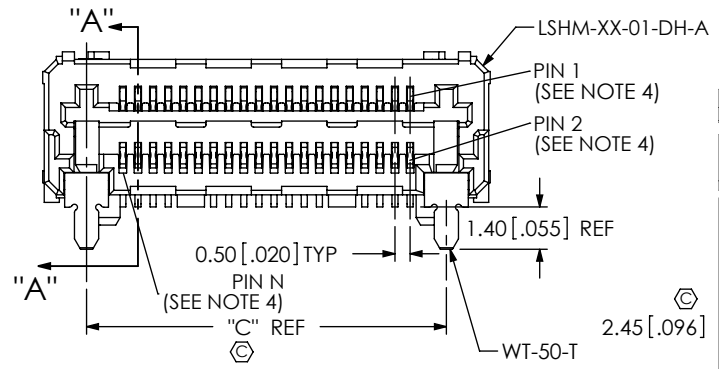
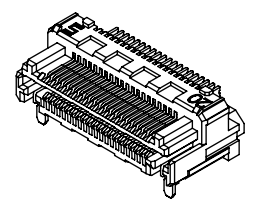
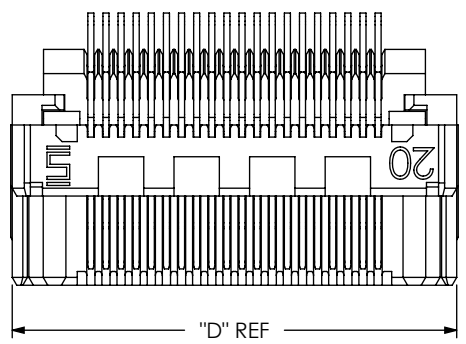

SECTION "A"- "A"  
SCALE 4:1

FIG 1  
LSHM-1XX-X1-XX-DH-A-N-X-XX SHOWN

- NOTES:
- ① REPRESENTS A CRITICAL DIMENSION.
  - BURR ALLOWANCE: .038[.0015].
  - MINIMUM PUSHOUT FORCE; TERMINALS: 2.22 N [.5 LBS], CONTACTS: 2.22 N [.5 LBS].
  - WHEN MATING WITH ANOTHER LSHM-DH, PIN 01 WILL MATE WITH CONTACT 02 ON MATING CONNECTOR. WHEN MATING WITH A LSHM-DV, PIN 01 WILL MATE WITH PIN N, WHERE N=TOTAL NUMBER OF POSITIONS
  - MEASURE FROM TOP OF VERTICAL WALL.
  - FOR QUANTITIES UP TO 49 PCS., NO LEADER, TRAILER OR REEL WILL BE SUPPLIED. FOR QUANTITIES OF 50-124 PCS., NO LEADER OR TRAILER WILL BE SUPPLIED.

F:\DWG\MISC\MKTG\LSHM-1XX-XX-X-DH-A-X-X-TR-MKT.SLDDRW

UNLESS OTHERWISE SPECIFIED, DIMENSIONS ARE IN MILLIMETERS[INCHES]. TOLERANCES ARE: DECIMALS ANGLES  
X.X: ±0.3 [.01] 2°  
X.XX: ±0.13 [.005]  
X.XXX: ±0.051 [.0020]

PROPRIETARY NOTE  
THIS DOCUMENT CONTAINS CONFIDENTIAL AND PROPRIETARY INFORMATION AND ALL DESIGN, MANUFACTURING, REPRODUCTION, USE, PATENT RIGHTS AND SALES RIGHTS ARE EXPRESSLY RESERVED BY SAMTEC, INC. THIS DOCUMENT SHALL NOT BE DISCLOSED, IN WHOLE OR PART, TO ANY UNAUTHORIZED PERSON OR ENTITY NOR REPRODUCED, TRANSFERRED OR INCORPORATED IN ANY OTHER PRODUCT IN ANY MANNER WITHOUT THE EXPRESS WRITTEN CONSENT OF SAMTEC, INC.

MATERIAL: DO NOT SCALE DRAWING SHEET SCALE: 1:0.2  
INSULATOR: BLACK, LCP, UL 94 V0  
TERMINAL: PHOS BRONZE  
SHIELD: STAINLESS STEEL  
WELD TAB: COPPER

|  |            |
|--|------------|
| <b>samtec</b>  |            |
| 520 PARK EAST BLVD. NEW ALBANY, IN 47150<br>PHONE: 812-944-6733 FAX: 812-948-5047<br>e-Mail info@SAMTEC.com code 55322 |            |
| DESCRIPTION:<br>0.50mm TERMINAL/SOCKET COMBO   |            |
| DWG. NO.<br>LSHM-1XX-XX-X-DH-A-X-X-TR  |            |
| BY: AGEN H   | 10/30/2008 |
| SHEET 1 OF 4   |            |

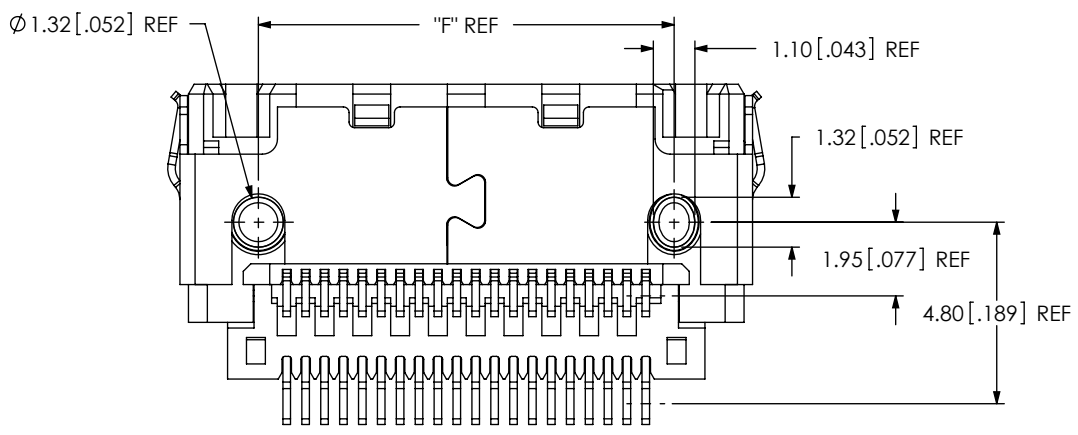
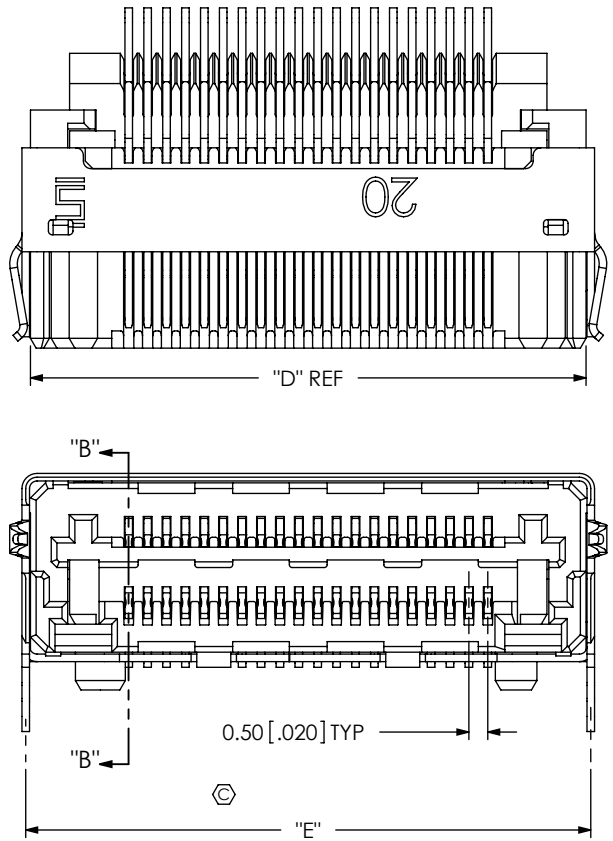

**FIG 2**  
(SHIELD OPTION)  
LSHM-1XX-X1-XX-DH-A-S-XX-XX SHOWN

F:\DWG\MISC\MKTG\LSHM-1XX-XX-X-DH-A-X-X-TR-MKT.SLDRW

| No OF POS | "C"           | "D"           | "E"           | "F"           | "G"           |
|-----------|---------------|---------------|---------------|---------------|---------------|
| -05       | 4.40 [0.173]  | 7.20 [0.283]  | 7.45 [0.293]  | 3.50 [0.138]  | 1.35 [0.053]  |
| -10       | 6.90 [0.272]  | 9.70 [0.382]  | 9.95 [0.392]  | 6.00 [0.236]  | 2.60 [0.102]  |
| -20       | 11.90 [0.469] | 14.70 [0.579] | 14.95 [0.589] | 11.00 [0.433] | 5.10 [0.201]  |
| -30       | 16.90 [0.665] | 19.70 [0.776] | 19.95 [0.785] | 16.00 [0.630] | 7.60 [0.299]  |
| -40       | 21.90 [0.862] | 24.70 [0.972] | 24.95 [0.982] | 21.00 [0.827] | 10.10 [0.398] |
| -50       | 26.90 [1.059] | 29.70 [1.169] | 29.95 [1.179] | 26.00 [1.024] | 12.60 [0.496] |

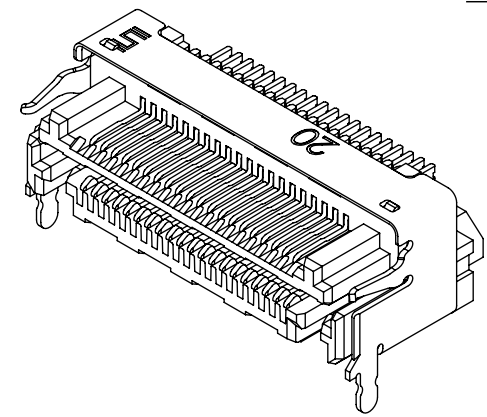
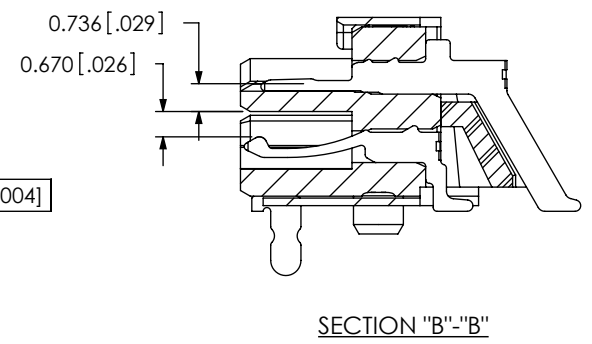
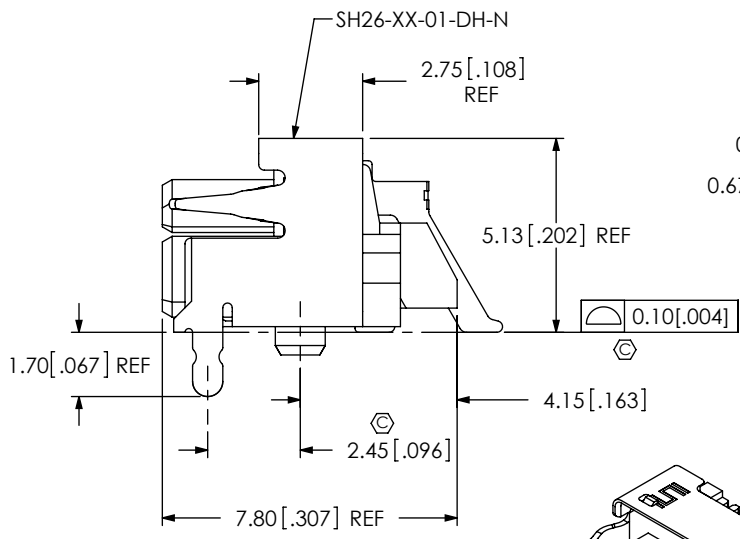

|   |  |  |
|---|--|--|
| <p><b>PROPRIETARY NOTE</b></p> <p>THIS DOCUMENT CONTAINS CONFIDENTIAL AND PROPRIETARY INFORMATION AND ALL DESIGN, MANUFACTURING, REPRODUCTION, USE, PATENT RIGHTS AND SALES RIGHTS ARE EXPRESSLY RESERVED BY SAMTEC, INC. THIS DOCUMENT SHALL NOT BE DISCLOSED, IN WHOLE OR PART, TO ANY UNAUTHORIZED PERSON OR ENTITY NOR REPRODUCED, TRANSFERRED OR INCORPORATED IN ANY OTHER PROJECT IN ANY MANNER WITHOUT THE EXPRESS WRITTEN CONSENT OF SAMTEC, INC.</p> | <p><b>samtec</b></p> <p>520 PARK EAST BLVD, NEW ALBANY, IN 47150<br/>         PHONE: 812-944-6733 FAX: 812-948-5047<br/>         e-Mail info@SAMTEC.com code 55322</p> |  |
|   | <p>DO NOT SCALE DRAWING<br/>SHEET SCALE: 1:0.2</p>   |  |
|   | <p>DESCRIPTION:<br/>0.50mm TERMINAL/SOCKET COMBO</p> <p>DWG. NO.<br/>LSHM-1XX-XX-X-DH-A-X-X-TR</p> <p>BY: AGEN H 10/30/2008 SHEET 2 OF 4</p>                           |  |

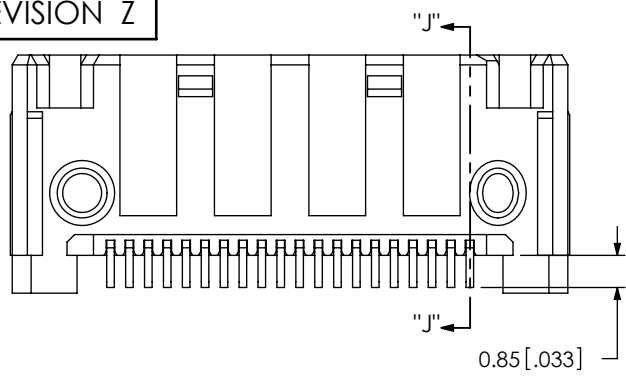
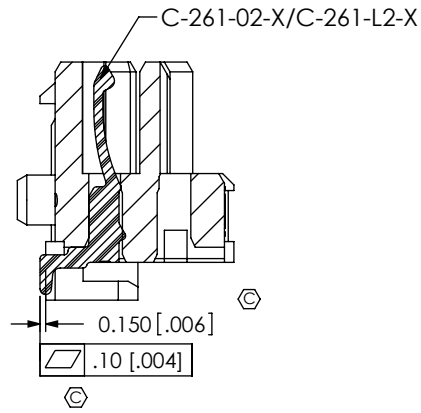

FIG 4  
(IN PROCESS 1)



SECTION "J"-"J"

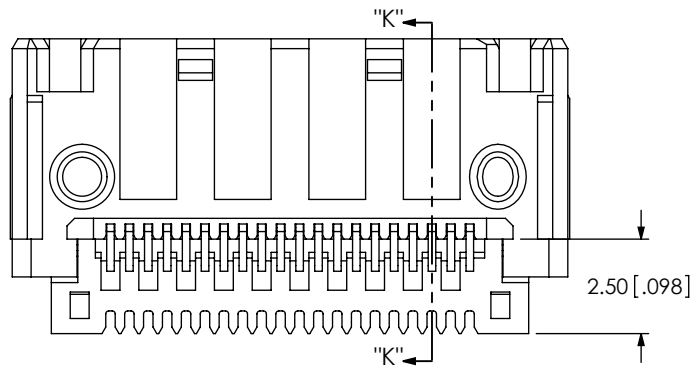
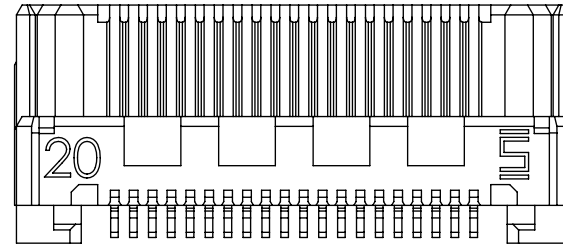
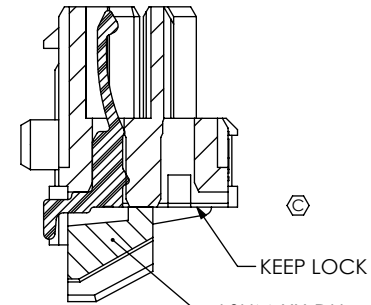

FIG 5  
(IN PROCESS 2)



SECTION "K"-"K"

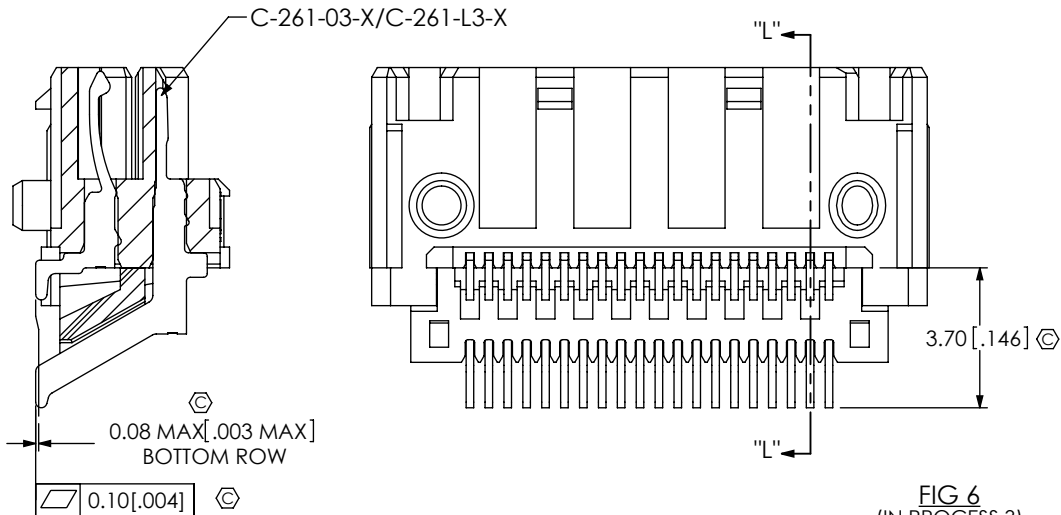

FIG 6  
(IN PROCESS 3)

**PROPRIETARY NOTE**  
 THIS DOCUMENT CONTAINS CONFIDENTIAL AND PROPRIETARY INFORMATION AND ALL DESIGN, MANUFACTURING, REPRODUCTION, USE, PATENT RIGHTS AND SALES RIGHTS ARE EXPRESSLY RESERVED BY SAMTEC, INC. THIS DOCUMENT SHALL NOT BE DISCLOSED, IN WHOLE OR PART, TO ANY UNAUTHORIZED PERSON OR ENTITY NOR REPRODUCED, TRANSFERRED OR INCORPORATED IN ANY OTHER PROJECT IN ANY MANNER WITHOUT THE EXPRESS WRITTEN CONSENT OF SAMTEC, INC.



520 PARK EAST BLVD, NEW ALBANY, IN 47150  
 PHONE: 812-944-6733 FAX: 812-948-5047  
 e-Mail info@SAMTEC.com code 55322

DO NOT SCALE DRAWING  
 SHEET SCALE: 5:1

DESCRIPTION:  
 0.50mm TERMINAL/SOCKET COMBO

DWG. NO.  
**LSHM-1XX-XX-X-DH-A-X-X-TR**

BY: AGEN H 10/30/2008 SHEET 3 OF 4

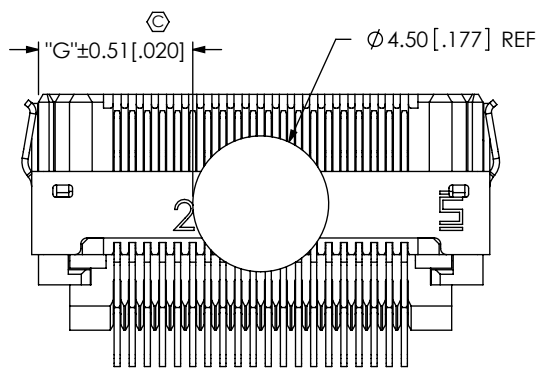

| TABLE 2    |            |
|------------|------------|
| LEAD STYLE | CONTACT    |
| -01        | C-261-02-X |
|            | C-261-03-X |
| -L1        | C-261-L2-X |
|            | C-261-L3-X |

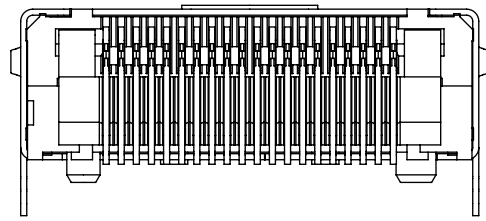



FIG 7  
LSHM-1XX-X1-XX-DH-A-S-XX-XX SHOWN

F:\DWG\MISC\MKTG\LSHM-1XX-XX-X-DH-A-X-X-TR-MKT.SLDDRW

|   |  |  |
|---|--|--|
| <p><b>PROPRIETARY NOTE</b></p> <p>THIS DOCUMENT CONTAINS CONFIDENTIAL AND PROPRIETARY INFORMATION AND ALL DESIGN, MANUFACTURING, REPRODUCTION, USE, PATENT RIGHTS AND SALES RIGHTS ARE EXPRESSLY RESERVED BY SAMTEC, INC. THIS DOCUMENT SHALL NOT BE DISCLOSED, IN WHOLE OR PART, TO ANY UNAUTHORIZED PERSON OR ENTITY NOR REPRODUCED, TRANSFERRED OR INCORPORATED IN ANY OTHER PROJECT IN ANY MANNER WITHOUT THE EXPRESS WRITTEN CONSENT OF SAMTEC, INC.</p> |   |  |
|   | <p>520 PARK EAST BLVD., NEW ALBANY, IN 47150<br/>                 PHONE: 812-944-6733 FAX: 812-948-5047<br/>                 e-Mail info@SAMTEC.com code 55322</p> |  |
|   | <p>DO NOT SCALE DRAWING</p>  | <p>DESCRIPTION:<br/>0.50mm TERMINAL/SOCKET COMBO</p> |
| <p>BY: AGEN H 10/30/2008</p>  |  | <p>SHEET 4 OF 4</p>                                  |