

Rochester Electronics Manufactured Components

Rochester branded components are manufactured using either die/wafers purchased from the original suppliers or Rochester wafers recreated from the original IP. All recreations are done with the approval of the OCM.

Parts are tested using original factory test programs or Rochester developed test solutions to guarantee product meets or exceed the OCM data sheet.

Quality Overview

- ISO-9001
- AS9120 certification
- Qualified Manufacturers List (QML) MIL-PRF-35835
 - Class Q Military
 - Class V Space Level
- Qualified Suppliers List of Distributors (QSLD)
 - Rochester is a critical supplier to DLA and meets all industry and DLA standards.

Rochester Electronics, LLC is committed to supplying products that satisfy customer expectations for quality and are equal to those originally supplied by industry manufacturers.

The original manufacturer's datasheet accompanying this document reflects the performance and specifications of the Rochester manufactured version of this device. Rochester Electronics guarantees the performance of its semiconductor products to the original OEM specifications. 'Typical' values are for reference purposes only. Certain minimum or maximum ratings may be based on product characterization, design, simulation, or sample testing.

FEATURES

- Fully Differential High Impedance Voltage Sensing
- Accurate Current Amplifier for Precise Current Sharing
- Opto Coupler Driving Capability
- 1.25% Trimmed Reference
- Master Status Indication
- 4.5-V to 35-V Operation

SOIC-16 DW PACKAGE
(TOP VIEW)

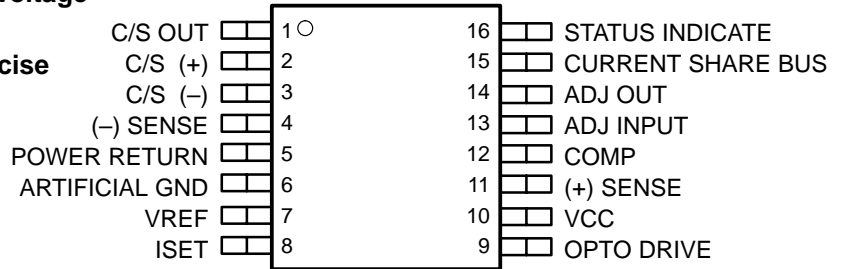

PLCC-20, LCC-20,
Q OR L PACKAGE
(TOP VIEW)

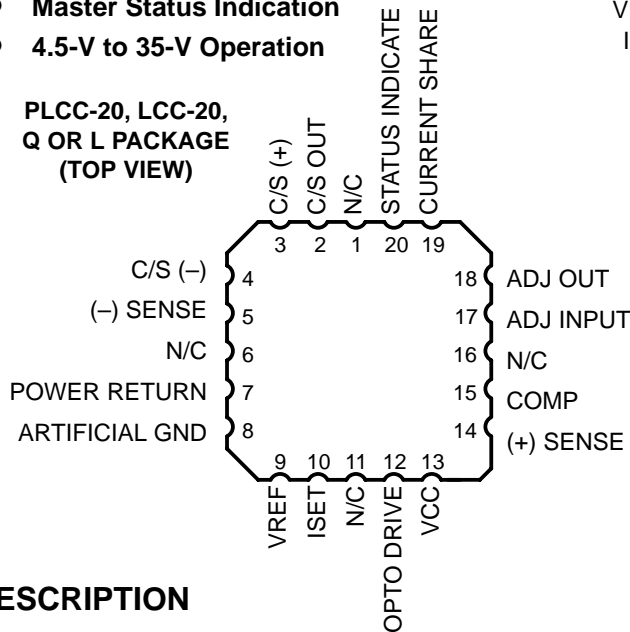

DIL-16 J or N PACKAGE
(TOP VIEW)

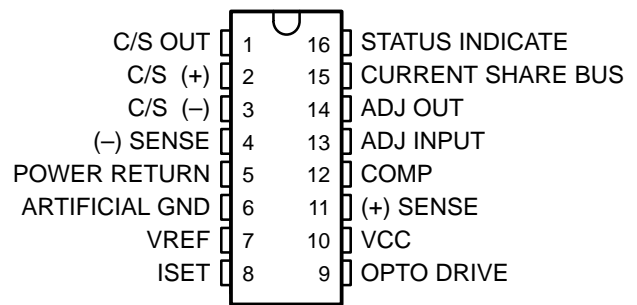

DESCRIPTION

The UCx907 family of load share controller ICs provides all the necessary features to allow multiple-independent-power modules to be paralleled such that each module supplies only its proportionate share to total-load current.

This sharing is accomplished by controlling each module's power stage with a command generated from a voltage-feedback amplifier whose reference can be independently adjusted in response to a common-share-bus voltage. By monitoring the current from each module, the current share bus circuitry determines which paralleled module would normally have the highest output current and, with the designation of this unit as the master, adjusts all the other modules to increase their output current to within 2.5% of that of the master.

The current share bus signal interconnecting all the paralleled modules is a low-impedance, noise-insensitive line which will not interfere with allowing each module to act independently should the bus become open or shorted to ground. The UC3907 controller will reside on the output side of each power module and its overall function is to supply a voltage feedback loop. The specific architecture of the power stage is unimportant. Either switching or linear designs may be utilized and the control signal may be either directly coupled or isolated though the use of an optocoupler or other isolated medium.

Other features of the UC3907 include 1.25% accurate reference: a low-loss, fixed-gain current-sense amplifier, a fully differential, high-impedance voltage sensing capability, and a status indicator to designate which module is performing as master.



Please be aware that an important notice concerning availability, standard warranty, and use in critical applications of Texas Instruments semiconductor products and disclaimers thereto appears at the end of this data sheet.

PRODUCTION DATA information is current as of publication date. Products conform to specifications per the terms of Texas Instruments standard warranty. Production processing does not necessarily include testing of all parameters.

UC1907, UC2907, UC3907 LOAD SHARE CONTROLLER

SLUS165C – MARCH 1999 - REVISED JANUARY 2002

block diagram

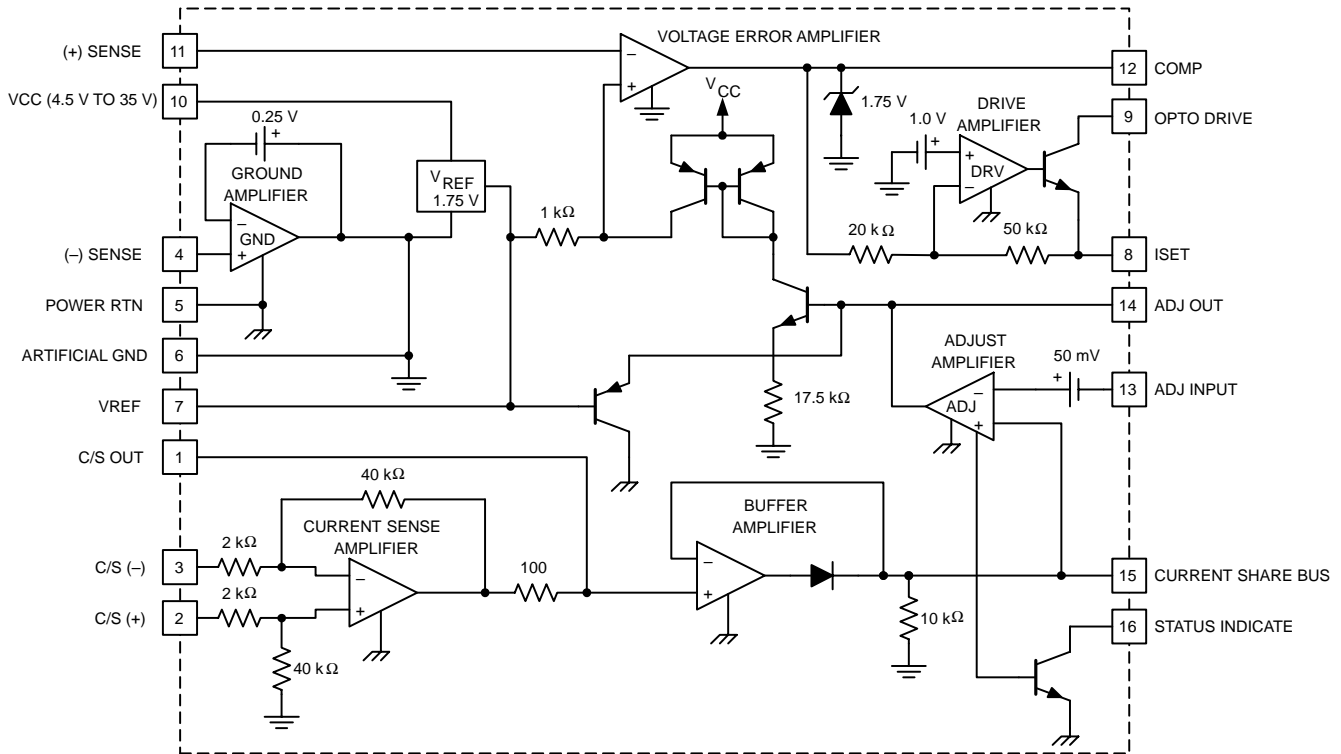

absolute maximum ratings over operating free-air temperature (unless otherwise noted)†

Supply voltage	35 V
Opto out voltage	35 V
Opto out current	20 mA
Status indicate sink current	20 mA
C/S input voltage	35 V
Share bus voltage	-0.3 V to 35 V
Other analog inputs and outputs (zener clamped) maximum forced voltage	-0.3 V to 10 V
Other analog inputs and outputs (zener clamped) maximum forced current	±10 mA
Ground amp sink current	50 mA
Pins 1, 9, 12, 15 sink current	20 mA
Storage temperature range, T_{stg}	-65°C to 150°C
Junction temperature, T_J	-55°C to 150°C
Lead temperature (solder 10 seconds)	300°C

† Pin Nos. refer to 16 Pin DIL Package.

‡ Currents are positive into, negative out of the specified terminal. Consult packaging section of databook for thermal limitations and considerations of package.

UC1907, UC2907, UC3907 LOAD SHARE CONTROLLER

SLUS165C – MARCH 1999 - REVISED JANUARY 2002

electrical characteristics, these specifications apply for $T_A = -55^\circ\text{C}$ to 125°C for UC1907, -40°C to 85°C for UC2907, and 0°C to 70°C for UC3907, $V_{IN} = 15\text{ V}$, $T_A = T_J$ (unless otherwise stated)

PARAMETER	TEST CONDITIONS	MIN	TYP	MAX	UNITS
Voltage Amp Section					
Input voltage	COMP = 1 V, $T_A = 25^\circ\text{C}$	1.975	2.000	2.025	V
	COMP = 1 V, over temp	1.960	2.000	2.040	V
Line regulation	$V_{IN} = 4.5\text{ V to }35\text{ V}$			15	mV
Load regulation	I_L reference = 0.0 mA to -10 mA			10	mV
Long term stability	$T_A = 125^\circ\text{C}$, 1000hrs See Note 2		5	25	mV
Total output variation	Line, load, temp	1.960		2.040	
Input adjust range	ADJ OUT from max high to max low	85	100	115	mV
Input bias current		-1			μA
Open loop gain	COMP = 0.75 V to 1.5 V	65			dB
Unity gain bandwidth	$T_A = 25^\circ\text{C}$ See Note 2	700			kHz
Output sink current	(+) SENSE = 2.2 V, COMP = 1 V	6	15		mA
Output source current	(+) SENSE = 1.8 V, COMP = 1 V	400	600		μA
V_{OUT} high	(+) SENSE = 1.8 V, $I_L = -400\ \mu\text{A}$	1.85	2		V
V_{OUT} low	(+) SENSE = 2.2 V, $I_L = 1\text{ mA}$		0.15	0.40	V
Reference Section					
Output voltage	$T_A = 25^\circ\text{C}$	1.970	2.000	2.030	V
	Over operating temp	1.955	2.000	2.045	V
Short circuit current	$V_{REF} = 0.0\text{ V}$	-15	-30	-60	mA
Ground Amp Section					
Output voltage		200	250	300	mV
Common mode variation	(-) SENSE from 0.0 V to 2 V			5	mV
Load regulation	$I_L = 0.0\text{ mA to }20\text{ mA}$, $T_A = 25^\circ\text{C}$			10	mV
	$I_L = 0.0\text{ mA to }20\text{ mA}$, over temp			15	mV
Adjust Amp Section					
Input offset voltage	ADJ OUT = 1.5 V, $V_{CM} = 0.0\text{ V}$	40	50	60	mV
Input bias current		-2			μA
Open loop gain	$1.5\text{ V} \leq \text{ADJ OUT} \leq 2.25\text{ V}$	65			dB
Unity gain bandwidth	$T_A = 25^\circ\text{C}$, $C_{OUT} = 1\ \mu\text{F}$ See Note 2		500		Hz
Transconductance	$I_{OUT} = -10\ \mu\text{A to }10\ \mu\text{A}$, $V_{OUT} = 1.5\text{ V}$	1.7	3	4.5	ms
Output sink current	$V_{ID} = 0.0\text{ V}$, ADJ OUT = 1.5 V	55	135	225	μA
Output source current	$V_{ID} = 250\text{ mV}$, ADJ OUT = 1.5 V	110	200	350	μA
V_{OUT} high	$V_{ID} = 250\text{ mV}$, $I_{OUT} = -50\text{ mA}$	2.20	2.70	2.90	V
V_{OUT} low	$V_{ID} = 0.0\text{ V}$, $I_{OUT} = 50\text{ mA}$		0.75	1.15	V
Common mode rejection ratio	$V_{CM} = 0.0\text{ to }10\text{ V}$	70			dB
Output gain to V/A	V_{OUT} ADJ OUT = 1.5 V to 2 V, $\Delta(+)$ SENSE/ Δ ADJ OUT	50	57	64	mV/V

NOTE 1: Unless otherwise specified all voltages are with respect to (-) SENSE. Currents are positive into, negative out of the specified terminal.

NOTE 2: Ensured by design. Not production tested.

UC1907, UC2907, UC3907 LOAD SHARE CONTROLLER

SLUS165C – MARCH 1999 - REVISED JANUARY 2002

electrical characteristics, these specifications apply for $T_A = -55^\circ\text{C}$ to 125°C for UC1907, -40°C to 85°C for UC2907, and 0°C to 70°C for UC3907, $V_{IN} = 15\text{ V}$, $T_A = T_J$ (unless otherwise stated)

PARAMETER	TEST CONDITIONS	MIN	TYP	MAX	UNITS
Current Amp Section					
Gain	$V_{CM} = 0.0\text{ V}$, $V_{ID} = 50\text{ mV to }100\text{ mV}$	19.2	19.6	20.1	V/V
Output voltage	$V_{C/S (+)} = V_{C/S (-)} = 0.0\text{ V}$, $T_A = 25^\circ\text{C}$	210	250	290	mV
	$V_{C/S (+)} = V_{C/S (-)} = 0.0\text{ V}$, over temp	180	250	330	mV
Input offset change with common mode input	$V_{CM} = 0\text{ V to }13\text{ V}$			600	$\mu\text{V/V}$
V_{OUT} high	$V_{ID} = 1\text{ V}$	10	14.5		V
V_{OUT} low	$V_{ID} = -1\text{ V}$, $I_L = 1\text{ mA}$		350	450	mV
Power supply rejection ratio	$V_{IN} = 4.5\text{ V to }35\text{ V}$, $V_{CM} = 0.0\text{ V}$	60			dB
Slew rate			0.4		$\text{V}/\mu\text{s}$
Drive Amp Section $R_{SET} = 500\ \Omega$ to Artificial GND, Opto Drive = 15 V					
Voltage gain	COMP = 0.5 V to 1 V	2.3	2.5	2.6	V/V
I_{SET} V_{OUT} high	(+) SENSE = 2.2 V	3.8	4.1	4.4	V
I_{SET} V_{OUT} low	(+) SENSE = 1.8 V		270	300	mV
Opto out voltage range		4		35	V
Zero current input threshold		1.55	1.65	1.75	V
Buffer Amp Section					
Input offset voltage	Input = 1 V			5	mV
Output off impedance	Input = 1 V, output = 1.5 V to 2 V	5	10	20	$\text{k}\Omega$
Output source current	Input = 1 V, output = 0.5 V	6	15		mA
Common mode rejection ratio	$V_{CM} = 0.3\text{ V to }10\text{ V}$	70			dB
Power supply rejection ratio	$V_{IN} = 4.5\text{ V to }35\text{ V}$	70			dB
Under Voltage Lockout Section					
Startup threshold			3.7	4.4	V
Threshold hysteresis			200		mV
Status Indicate Section					
V_{OUT} low	ADJ OUT = current share bus		0.2	0.5	V
Output leakage	ADJ OUT = 1 V, $V_{OUT} = 35\text{ V}$		0.1	5	μA
Total Stand by Current Section					
Startup current	$V_{IN} = UVLO - 0.2\text{ V}$		3	5	mA
Operating current	$V_{IN} = 35\text{ V}$		6	10	mA

NOTE 1: Unless otherwise specified all voltages are with respect to (-) SENSE. Currents are positive into, negative out of the specified terminal.

NOTE 2: Ensured by design. Not production tested.

pin assignments

(–) SENSE: (Pin 4) This is a high-impedance pin allowing remote sensing of the system ground, bypassing any voltage drops which might appear in the power return line. This point should be considered as the true ground. Unless otherwise stated, all voltages are with respect to this point.

Artificial Ground: (Pin 6) This is a low-impedance-circuit ground which is exactly 250 mV above the (–) SENSE terminal. This offset allows the ground buffer amplifier negative headroom to return all the control bias and operating currents while maintaining a high impedance at the (–) SENSE input.

Power RTN: (Pin 5) This should be the most negative voltage available and can range from zero to 5 V below the (–) SENSE terminal. It should be connected as close to the power source as possible so that voltage drops across the return line and current-sensing impedances lie between this terminal and the (–) SENSE point.

VREF: (Pin 7) The internal voltage reference is a band-gap circuit set at 2.0 V with respect to the (–) SENSE input (1.75 V above the artificial ground), and an accuracy of $\pm 1.5\%$. This circuit, as well as all the other chip functions, will work over a supply voltage range of 4.5 V to 35 V allowing operation from unregulated dc, an auxiliary voltage, or the same output voltage that it is controlling. Under-voltage lockout has been included to insure proper startup by disabling internal bias currents until the reference rises into regulation.

Voltage Amplifier: (Pins 11, 12) This circuit is the feedback-control-gain stage for the power module's output-voltage regulation, and overall-loop compensation will normally be applied around this amplifier. Its output will swing from slightly above the ground return to an internal clamp of 2.0 V. The reference trimming is performed closed loop, and measured at pin 11, (+) SENSE. The value is trimmed to $2\text{ V} \pm 1.25\%$.

Drive Amplifier: (Pins 8, 9, 12) This amplifier is used as an inverting buffer between the voltage amplifier's output and the medium used to couple the feedback signal to the power controller. It has a fixed-voltage gain of 2.5 and is usually configured with a current-setting resistor to ground. This establishes a current-sinking output optimized to drive optical couplers biased at any voltage from 4.5 V to 35 V, with current levels up to 20 mA. The polarity of this stage is such that an increasing voltage at the voltage amplifier's sense input (as, for example, at turnon) will increase the opto's current. In a nonisolated application, a voltage signal ranging from 0.25 V to 4.1 V may be taken from the current-setting output but it should be noted that this voltage will also increase with increasing sense voltage and an external inverter may be required to obtain the correct feedback polarity.

Current Amplifier: (Pins 1, 2, 3) This amplifier has differential-sensing capability for use with an external shunt in the power-return line. The common mode range of its input will accommodate the full range between the power return point and $V_{CC}-2\text{ V}$ which will allow undefined-line impedances on either side of the current shunt. The gain is internally set at 20, giving the user the ability to establish the maximum-voltage drop across the current-sense resistor at any value between 50 mV and 500 mV. While the bandwidth of this amplifier may be reduced with the addition of an external-output capacitor to ground, in most cases this is not required as the compensation of the adjust amplifier will typically form the dominant pole in the adjust loop.

Buffer Amplifier: (Pins 1, 15) This amplifier is a unidirectional buffer which drives the current-share bus. The line which will interconnect all power modules paralleled for current sharing. Since the buffer amplifier will only source current, it insures that the module with the highest-output current will be the master and drive the bus with a low-impedance drive capability. All other buffer amplifiers will be inactive with each exhibiting a 10-k Ω load impedance to ground. The share bus terminal is protected against both shorts to ground and accidental voltages in excess of 50 V.

UC1907, UC2907, UC3907 LOAD SHARE CONTROLLER

SLUS165C – MARCH 1999 - REVISED JANUARY 2002

pin assignments

Adjust Amplifier: (Pins 13, 14, 15) This amplifier adjusts the individual module's reference voltage to maintain equal-current sharing. It is a transconductance type in order that its bandwidth may be limited and noise kept out of the reference-adjust circuitry, with a simple capacitor to ground. The function of this amplifier is to compare its own module-output current to the share-bus signal, which represents the highest output current. This will force an adjust command which is capable of increasing the reference voltage as seen by the voltage amplifier by as much as 100 mV. This number stems from the 17.5:1 internal resistor ratio between the adjust amplifier's clamped output and the reference, and represents a 5% total range of adjustment. This value should be adequate to compensate for unit-to-unit reference and external-resistor tolerances. The adjust amplifier has a built-in 50-mV offset on its inverting input which will force the unit acting as the master to have a low output, resulting in no change to the reference. While this 50-mV offset represents an error in current sharing, the gain of the current amplifier reduces it to only 2.5 mV across the current-sense resistor. It should also be noted that when the module is acting independently with no connection to the share bus node, or when the share bus node is shorted to ground, its reference voltage will be unchanged. Since only the circuit acting as a master will have a low output from the adjust amplifier, this signal is used to activate a flag output to identify the master, should some corrective action be needed.

Status Indicate: (Pin 16) This pin is an open-collector output intended to indicate the unit which is acting as the master. It achieves this by sensing when the adjust amp is in its low state and pulling the status-indicate pin low.

additional information

Please refer to additional application information.

1. By Mark Jordan, *UC3907 Load Share IC Simplifies Parallel Power Supply Design*, TI Literature Number SLUA147.
2. By Laszlo Balogh, *UC3902 Load Share Controller and its Performance in Distributed Power Systems*, TI Literature Number SLUA128.

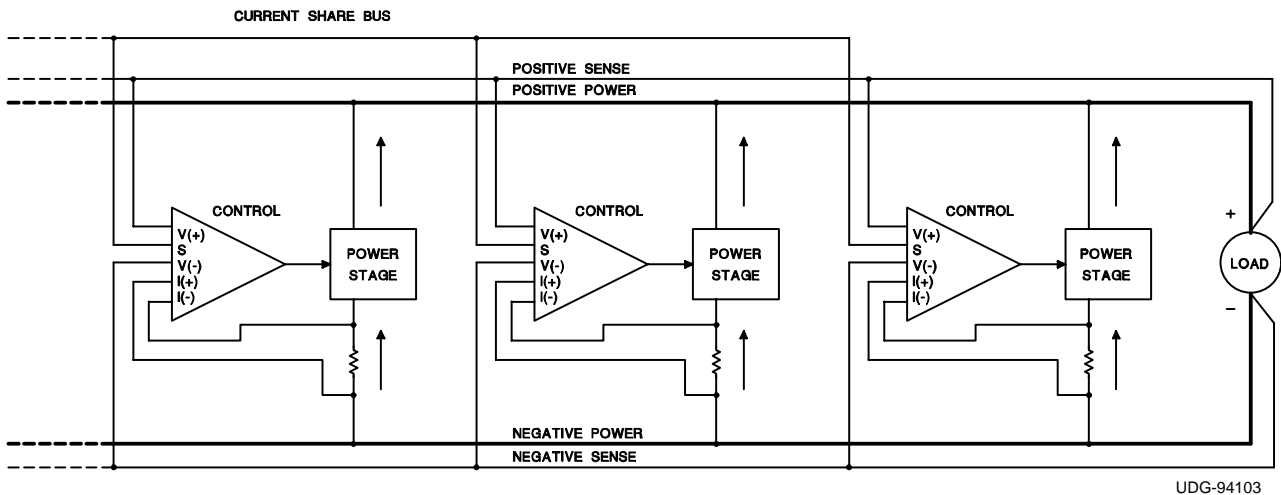

PACKAGING INFORMATION

Orderable Device	Status ⁽¹⁾	Package Type	Package Drawing	Pins	Package Qty	Eco Plan ⁽²⁾	Lead/Ball Finish	MSL Peak Temp ⁽³⁾
UC1907J	OBSOLETE	CDIP	J	16		TBD	Call TI	Call TI
UC1907J883B	OBSOLETE	CDIP	J	16		TBD	Call TI	Call TI
UC1907L	OBSOLETE	LCCC	FK	20		TBD	Call TI	Call TI
UC1907L883B	OBSOLETE	LCCC	FK	20		TBD	Call TI	Call TI
UC2907DW	ACTIVE	SOIC	DW	16	40	Green (RoHS & no Sb/Br)	CU NIPDAU	Level-2-260C-1 YEAR
UC2907DWG4	ACTIVE	SOIC	DW	16	40	Green (RoHS & no Sb/Br)	CU NIPDAU	Level-2-260C-1 YEAR
UC2907DWTR	ACTIVE	SOIC	DW	16	2000	Green (RoHS & no Sb/Br)	CU NIPDAU	Level-2-260C-1 YEAR
UC2907DWTRG4	ACTIVE	SOIC	DW	16	2000	Green (RoHS & no Sb/Br)	CU NIPDAU	Level-2-260C-1 YEAR
UC2907J	OBSOLETE	CDIP	J	16		TBD	Call TI	Call TI
UC2907N	ACTIVE	PDIP	N	16	25	Green (RoHS & no Sb/Br)	CU NIPDAU	N / A for Pkg Type
UC2907NG4	ACTIVE	PDIP	N	16	25	Green (RoHS & no Sb/Br)	CU NIPDAU	N / A for Pkg Type
UC3907DW	ACTIVE	SOIC	DW	16	40	Green (RoHS & no Sb/Br)	CU NIPDAU	Level-2-260C-1 YEAR
UC3907DWG4	ACTIVE	SOIC	DW	16	40	Green (RoHS & no Sb/Br)	CU NIPDAU	Level-2-260C-1 YEAR
UC3907DWTR	ACTIVE	SOIC	DW	16	2000	Green (RoHS & no Sb/Br)	CU NIPDAU	Level-2-260C-1 YEAR
UC3907DWTRG4	ACTIVE	SOIC	DW	16	2000	Green (RoHS & no Sb/Br)	CU NIPDAU	Level-2-260C-1 YEAR
UC3907J	OBSOLETE	CDIP	J	16		TBD	Call TI	Call TI
UC3907N	ACTIVE	PDIP	N	16	25	Green (RoHS & no Sb/Br)	CU NIPDAU	N / A for Pkg Type
UC3907NG4	ACTIVE	PDIP	N	16	25	Green (RoHS & no Sb/Br)	CU NIPDAU	N / A for Pkg Type

⁽¹⁾ The marketing status values are defined as follows:

ACTIVE: Product device recommended for new designs.

LIFEBUY: TI has announced that the device will be discontinued, and a lifetime-buy period is in effect.

NRND: Not recommended for new designs. Device is in production to support existing customers, but TI does not recommend using this part in a new design.

PREVIEW: Device has been announced but is not in production. Samples may or may not be available.

OBSOLETE: TI has discontinued the production of the device.

⁽²⁾ Eco Plan - The planned eco-friendly classification: Pb-Free (RoHS), Pb-Free (RoHS Exempt), or Green (RoHS & no Sb/Br) - please check <http://www.ti.com/productcontent> for the latest availability information and additional product content details.

TBD: The Pb-Free/Green conversion plan has not been defined.

Pb-Free (RoHS): TI's terms "Lead-Free" or "Pb-Free" mean semiconductor products that are compatible with the current RoHS requirements for all 6 substances, including the requirement that lead not exceed 0.1% by weight in homogeneous materials. Where designed to be soldered at high temperatures, TI Pb-Free products are suitable for use in specified lead-free processes.

Pb-Free (RoHS Exempt): This component has a RoHS exemption for either 1) lead-based flip-chip solder bumps used between the die and package, or 2) lead-based die adhesive used between the die and leadframe. The component is otherwise considered Pb-Free (RoHS compatible) as defined above.

Green (RoHS & no Sb/Br): TI defines "Green" to mean Pb-Free (RoHS compatible), and free of Bromine (Br) and Antimony (Sb) based flame retardants (Br or Sb do not exceed 0.1% by weight in homogeneous material)

⁽³⁾ MSL, Peak Temp. -- The Moisture Sensitivity Level rating according to the JEDEC industry standard classifications, and peak solder

temperature.

Important Information and Disclaimer:The information provided on this page represents TI's knowledge and belief as of the date that it is provided. TI bases its knowledge and belief on information provided by third parties, and makes no representation or warranty as to the accuracy of such information. Efforts are underway to better integrate information from third parties. TI has taken and continues to take reasonable steps to provide representative and accurate information but may not have conducted destructive testing or chemical analysis on incoming materials and chemicals. TI and TI suppliers consider certain information to be proprietary, and thus CAS numbers and other limited information may not be available for release.

In no event shall TI's liability arising out of such information exceed the total purchase price of the TI part(s) at issue in this document sold by TI to Customer on an annual basis.

TAPE AND REEL INFORMATION

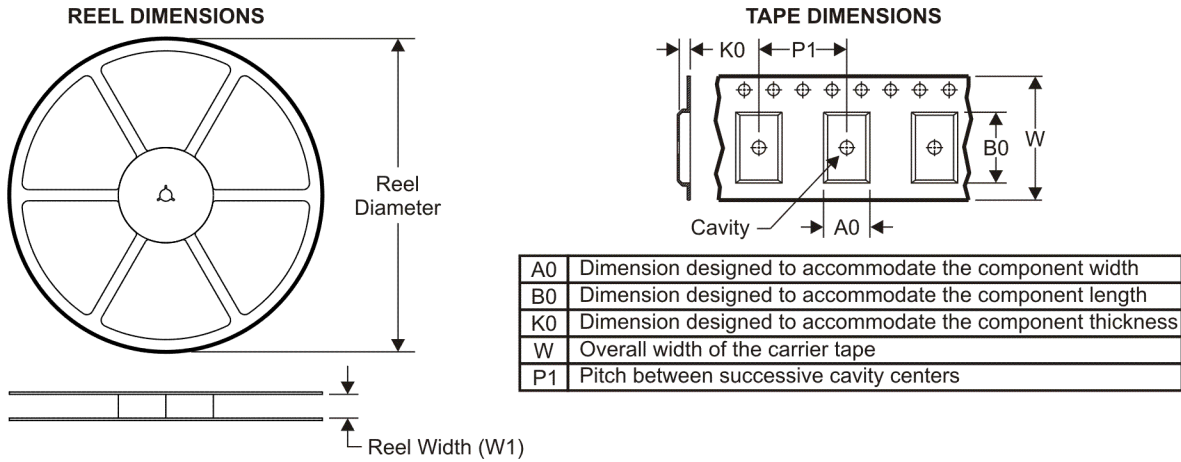

QUADRANT ASSIGNMENTS FOR PIN 1 ORIENTATION IN TAPE

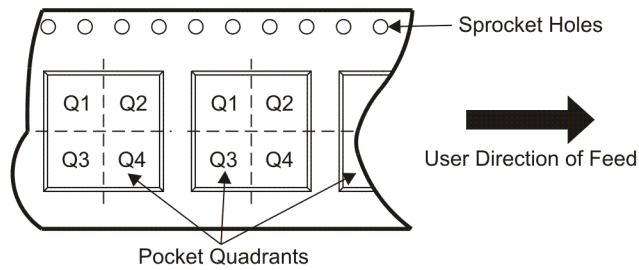

*All dimensions are nominal

Device	Package Type	Package Drawing	Pins	SPQ	Reel Diameter (mm)	Reel Width W1 (mm)	A0 (mm)	B0 (mm)	K0 (mm)	P1 (mm)	W (mm)	Pin1 Quadrant
UC2907DWTR	SOIC	DW	16	2000	330.0	16.4	10.85	10.8	2.7	12.0	16.0	Q1
UC3907DWTR	SOIC	DW	16	2000	330.0	16.4	10.85	10.8	2.7	12.0	16.0	Q1

TAPE AND REEL BOX DIMENSIONS

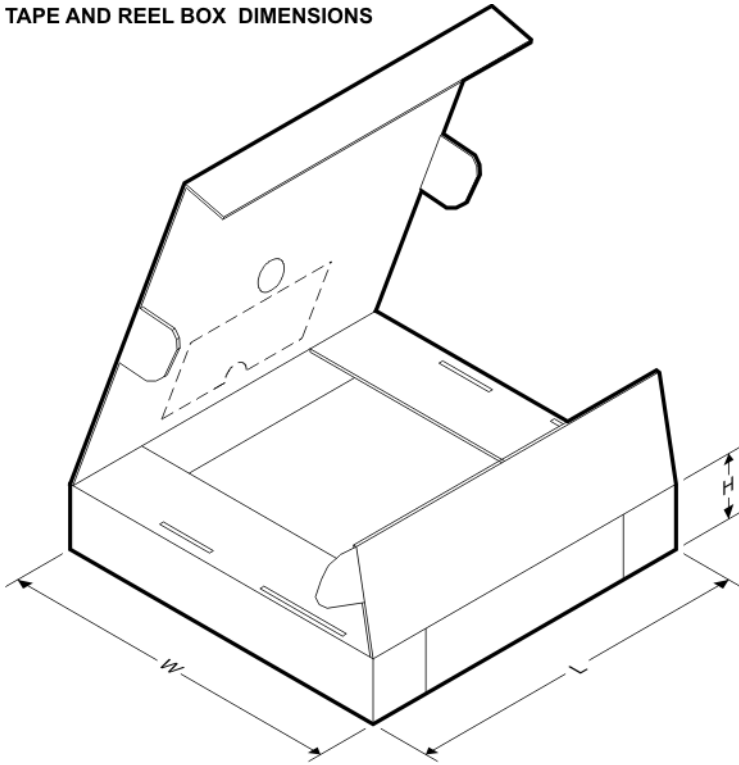

*All dimensions are nominal

Device	Package Type	Package Drawing	Pins	SPQ	Length (mm)	Width (mm)	Height (mm)
UC2907DWTR	SOIC	DW	16	2000	346.0	346.0	33.0
UC3907DWTR	SOIC	DW	16	2000	346.0	346.0	33.0

IMPORTANT NOTICE

Texas Instruments Incorporated and its subsidiaries (TI) reserve the right to make corrections, modifications, enhancements, improvements, and other changes to its products and services at any time and to discontinue any product or service without notice. Customers should obtain the latest relevant information before placing orders and should verify that such information is current and complete. All products are sold subject to TI's terms and conditions of sale supplied at the time of order acknowledgment.

TI warrants performance of its hardware products to the specifications applicable at the time of sale in accordance with TI's standard warranty. Testing and other quality control techniques are used to the extent TI deems necessary to support this warranty. Except where mandated by government requirements, testing of all parameters of each product is not necessarily performed.

TI assumes no liability for applications assistance or customer product design. Customers are responsible for their products and applications using TI components. To minimize the risks associated with customer products and applications, customers should provide adequate design and operating safeguards.

TI does not warrant or represent that any license, either express or implied, is granted under any TI patent right, copyright, mask work right, or other TI intellectual property right relating to any combination, machine, or process in which TI products or services are used. Information published by TI regarding third-party products or services does not constitute a license from TI to use such products or services or a warranty or endorsement thereof. Use of such information may require a license from a third party under the patents or other intellectual property of the third party, or a license from TI under the patents or other intellectual property of TI.

Reproduction of TI information in TI data books or data sheets is permissible only if reproduction is without alteration and is accompanied by all associated warranties, conditions, limitations, and notices. Reproduction of this information with alteration is an unfair and deceptive business practice. TI is not responsible or liable for such altered documentation. Information of third parties may be subject to additional restrictions.

Resale of TI products or services with statements different from or beyond the parameters stated by TI for that product or service voids all express and any implied warranties for the associated TI product or service and is an unfair and deceptive business practice. TI is not responsible or liable for any such statements.

TI products are not authorized for use in safety-critical applications (such as life support) where a failure of the TI product would reasonably be expected to cause severe personal injury or death, unless officers of the parties have executed an agreement specifically governing such use. Buyers represent that they have all necessary expertise in the safety and regulatory ramifications of their applications, and acknowledge and agree that they are solely responsible for all legal, regulatory and safety-related requirements concerning their products and any use of TI products in such safety-critical applications, notwithstanding any applications-related information or support that may be provided by TI. Further, Buyers must fully indemnify TI and its representatives against any damages arising out of the use of TI products in such safety-critical applications.

TI products are neither designed nor intended for use in military/aerospace applications or environments unless the TI products are specifically designated by TI as military-grade or "enhanced plastic." Only products designated by TI as military-grade meet military specifications. Buyers acknowledge and agree that any such use of TI products which TI has not designated as military-grade is solely at the Buyer's risk, and that they are solely responsible for compliance with all legal and regulatory requirements in connection with such use.

TI products are neither designed nor intended for use in automotive applications or environments unless the specific TI products are designated by TI as compliant with ISO/TS 16949 requirements. Buyers acknowledge and agree that, if they use any non-designated products in automotive applications, TI will not be responsible for any failure to meet such requirements.

Following are URLs where you can obtain information on other Texas Instruments products and application solutions:

Products

Amplifiers	amplifier.ti.com
Data Converters	dataconverter.ti.com
DSP	dsp.ti.com
Clocks and Timers	www.ti.com/clocks
Interface	interface.ti.com
Logic	logic.ti.com
Power Mgmt	power.ti.com
Microcontrollers	microcontroller.ti.com
RFID	www.ti-rfid.com
RF/IF and ZigBee® Solutions	www.ti.com/lprf

Applications

Audio	www.ti.com/audio
Automotive	www.ti.com/automotive
Broadband	www.ti.com/broadband
Digital Control	www.ti.com/digitalcontrol
Medical	www.ti.com/medical
Military	www.ti.com/military
Optical Networking	www.ti.com/opticalnetwork
Security	www.ti.com/security
Telephony	www.ti.com/telephony
Video & Imaging	www.ti.com/video
Wireless	www.ti.com/wireless

Mailing Address: Texas Instruments, Post Office Box 655303, Dallas, Texas 75265
Copyright © 2008, Texas Instruments Incorporated