

Rochester Electronics Manufactured Components

Rochester branded components are manufactured using either die/wafers purchased from the original suppliers or Rochester wafers recreated from the original IP. All recreations are done with the approval of the OCM.

Parts are tested using original factory test programs or Rochester developed test solutions to guarantee product meets or exceed the OCM data sheet.

Quality Overview

- ISO-9001
- AS9120 certification
- Qualified Manufacturers List (QML) MIL-PRF-35835
 - Class Q Military
 - Class V Space Level
- Qualified Suppliers List of Distributors (QSLD)
 - Rochester is a critical supplier to DLA and meets all industry and DLA standards.

Rochester Electronics, LLC is committed to supplying products that satisfy customer expectations for quality and are equal to those originally supplied by industry manufacturers.

The original manufacturer's datasheet accompanying this document reflects the performance and specifications of the Rochester manufactured version of this device. Rochester Electronics guarantees the performance of its semiconductor products to the original OEM specifications. 'Typical' values are for reference purposes only. Certain minimum or maximum ratings may be based on product characterization, design, simulation, or sample testing.

CDP1805AC, CDP1806AC

CMOS 8-Bit Microprocessor with On-Chip RAM† and Counter/Timer

March 1997

Features

- Instruction Time of 3.2 μ s, -40°C to +85°C
- 123 Instructions - Upwards Software Compatible With CDP1802
- BCD Arithmetic Instructions
- Low-Power IDLE Mode
- Pin Compatible With CDP1802 Except for Terminal 16
- 64K-Byte Memory Address Capability
- 64 Bytes of On-Chip RAM†
- 16 x 16 Matrix of On-Board Registers
- On-Chip Crystal or RC Controlled Oscillator
- 8-Bit Counter/Timer

Description

The CDP1805AC and CDP1806AC are functional and performance enhancements of the CDP1802 CMOS 8-bit register-oriented microprocessor series and are designed for use in general-purpose applications.

The CDP1805AC hardware enhancements include a 64-byte RAM and an 8-bit presettable down counter. The Counter/Timer which generates an internal interrupt request, can be programmed for use in timebase, event-counting, and pulse-duration measurement applications. The Counter/Timer underflow output can also be directed to the Q output terminal. The CDP1806AC hardware enhancements are identical to the CDP1805AC, except the CDP1806AC contains no on-chip RAM.

The CDP1805AC and CDP1806AC software enhancements include 32 more instructions than the CDP1802. The 32 new software instructions add subroutine call and return capability, enhanced data transfer manipulation, Counter/Timer control, improved interrupt handling, single-instruction loop counting, and BCD arithmetic.

Upwards software and hardware compatibility is maintained when substituting a CDP1805AC or CDP1806AC for other CDP1800-series microprocessors. Pinout is identical except for the replacement of V_{CC} with \overline{ME} on the CDP1805AC and the replacement of V_{CC} with V_{DD} on the CDP1806AC.

Ordering Information

CDP1805AC	CDP1806AC	TEMPERATURE RANGE	PACKAGE	PKG. NO.
CDP1805ACE	CDP1806ACE	-40°C to +85°C	Plastic DIP	E40.6
-	CDP1806ACEX		Burn-In	
CDP1805ACQ	CDP1806ACQ	-40°C to +85°C	PLCC	N44.65
CDP1805ACD	CDP1806ACD	-40°C to +85°C	SBDIP	D40.6
CDP1805ACDX	-		Burn-In	

† CDP1805AC Only

CDP1805AC, CDP1806AC

Pinouts

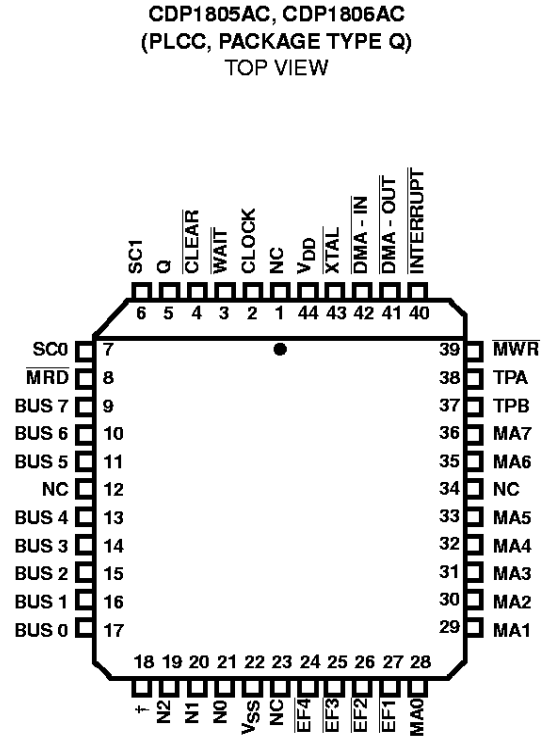
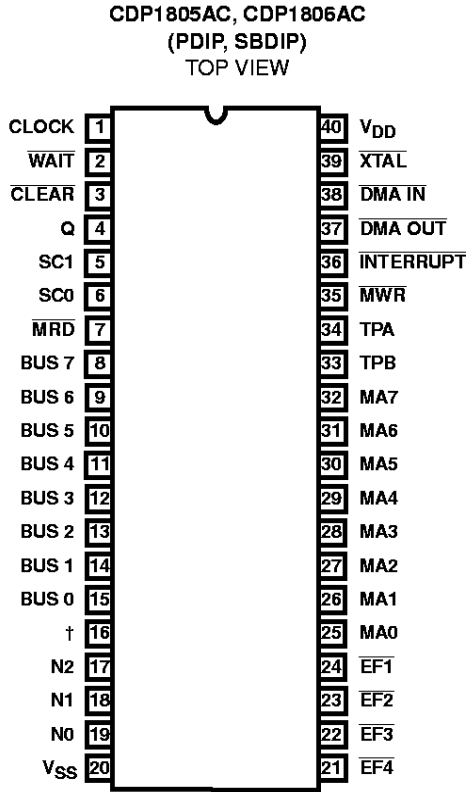

† ME for CDP1805AC
V_{DD} for CDP1806AC

Schematic

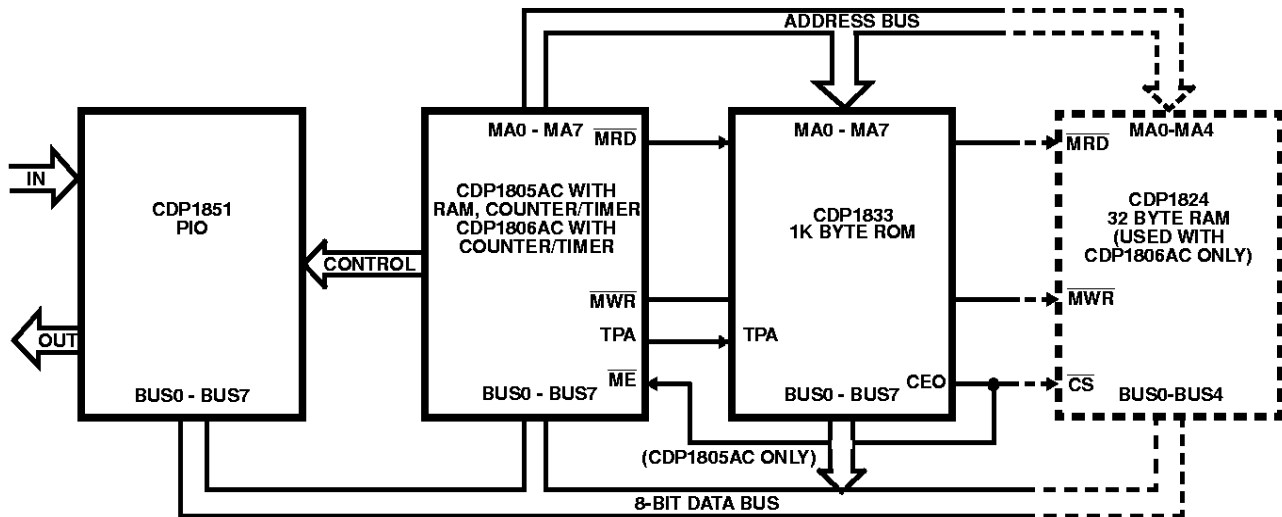

FIGURE 1. TYPICAL CDP1805AC, CDP1806AC SMALL MICROPROCESSOR SYSTEM

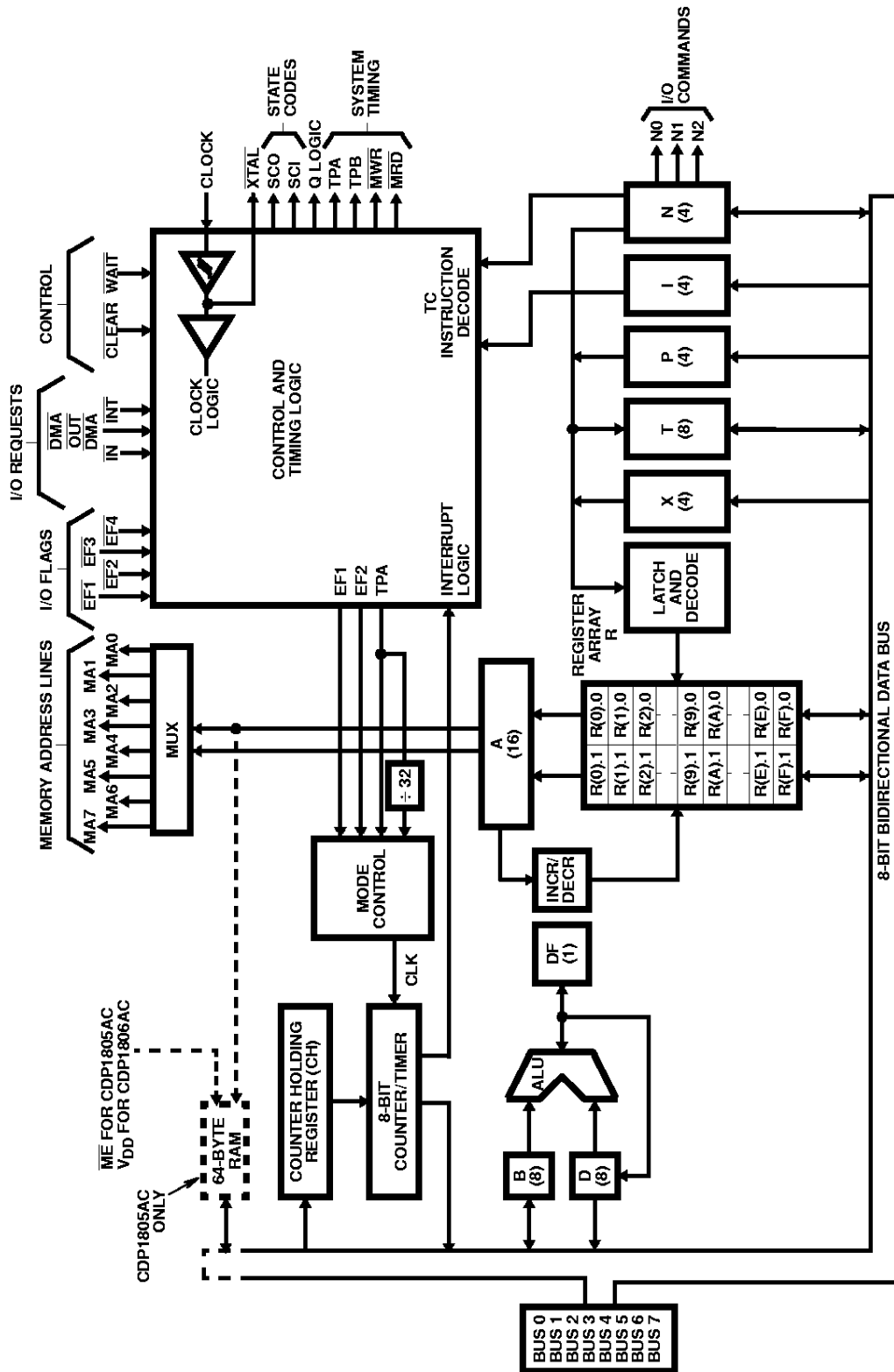

FIGURE 2. BLOCK DIAGRAM FOR CDP1805AC AND CDP1806AC

CDP1805AC, CDP1806AC

Absolute Maximum Ratings

DC Supply Voltage Range, (V_{DD})
(All Voltages Referenced to V_{SS} Terminal) -0.5V to +7V
Input Voltage Range, All Inputs -0.5V to $V_{DD} + 0.5V$
DC Input Current, any One Input $\pm 10mA$

Thermal Information

Thermal Resistance (Typical, Note 2) θ_{JA} ($^{\circ}C/W$) θ_{JC} ($^{\circ}C/W$)
 PDIP Package 50 N/A
 PLCC Package 46 N/A
 SBDIP Package 55 15
 Device Dissipation Per Output Transistor
 T_A = Full Package Temperature Range 100mW
 Operating Temperature Range (T_A)
 Package Type D -55 $^{\circ}C$ to +125 $^{\circ}C$
 Package Type E and Q -40 $^{\circ}C$ to +85 $^{\circ}C$
 Storage Temperature Range (T_{STG}) -65 $^{\circ}C$ to +150 $^{\circ}C$
 Lead Temperature (During Soldering)
 At Distance 1/16 \pm 1/32in (1.59 \pm 0.79mm) from case for
 10s Max +265 $^{\circ}C$
 Printed Circuit Board Mount: 57mm x 57mm Minimum Area x
 1.6mm Thick G10 Epoxy Glass, or Equivalent.

CAUTION: Stresses above those listed in "Absolute Maximum Ratings" may cause permanent damage to the device. This is a stress only rating and operation of the device at these or any other conditions above those indicated in the operational sections of this specification is not implied.

Recommended Operating Conditions T_A = Full-Package Temperature Range. For maximum reliability, operating conditions should be selected so that operation is always within the following ranges.

PARAMETER	TEST CONDITIONS V_{DD} (V)	CDP1805ACD, CDP1805ACE CDP1806ACD, CDP1806ACE		UNITS
		MIN	MAX	
DC Operating Voltage Range	-	4	6.5	V
Input Voltage Range	-	V_{SS}	V_{DD}	V
Minimum Instruction Time (Note 1) ($f_{CL} = 5MHz$)	5	3.2	-	μs
Maximum DMA Transfer Rate	5	-	0.625	Mbyte/s
Maximum Clock Input Frequency, Load Capacitance (C_L) = 50pF	5	DC	5	MHz
Maximum External Counter/Timer Clock Input Frequency to $\overline{EF1}$, $\overline{EF2}$	5	DC	2	MHz

NOTES:

1. Equals 2 machine cycles - one Fetch and one Execute operation for all instructions except Long Branch, Long Skip, NOP, and "68" family instructions, which are more than two cycles.
2. θ_{JA} is measured with the component mounted on an evaluation PC board in free air.

Static Electrical Specifications at $T_A = -40^{\circ}C$ to +85 $^{\circ}C$, $V_{DD} \pm 5\%$, Except as Noted

PARAMETER	V_O (V)	V_{IN} (V)	V_{DD} (V)	CDP1805ACD, CDP1805ACE CDP1806ACD, CDP1806ACE			UNITS
				MIN	(NOTE 3) TYP	MAX	
Quiescent Device Current, I_{DD}	-	0, 5	5	-	50	200	μA
Output Low Drive (Sink) Current, (Except \overline{XTAL}), I_{OL}	0.4	0, 5	5	1.6	4	-	mA
\overline{XTAL} Output, I_{OL}	0.4	5	5	0.2	0.4	-	mA
Output High Drive (Source) Current (Except \overline{XTAL}), I_{OH}	4.6	0, 5	5	-1.6	-4	-	mA
\overline{XTAL} , I_{OH}	4.6	0	5	-0.1	-0.2	-	mA
Output Voltage Low Level, V_{OL}	-	0, 5	5	-	0	0.1	V
Output Voltage High Level, V_{OH}	-	0, 5	5	4.9	5	-	V

CDP1805AC, CDP1806AC

Static Electrical Specifications at $T_A = -40^{\circ}\text{C}$ to $+85^{\circ}\text{C}$, $V_{DD} \pm 5\%$, Except as Noted (Continued)

PARAMETER	V_O (V)	V_{IN} (V)	V_{DD} (V)	CDP1805ACD, CDP1805ACE CDP1806ACD, CDP1806ACE			UNITS
				MIN	(NOTE 3) TYP	MAX	
Input Low Voltage (BUS0 - BUS7, \overline{ME}), V_{IL}	0.5, 4.5	-	5	-	-	1.5	V
Input High Voltage (BUS0 - BUS7, \overline{ME}), V_{IH}	0.5, 4.5	-	5	3.5	-	-	V
Schmitt Trigger Input Voltage (Except BUS0 - BUS7, \overline{ME})							
Positive Trigger Threshold, V_P	0.5, 4.5	-	5	2.2	2.9	3.6	V
Negative Trigger Threshold, V_N	0.5, 4.5	-	5	0.9	1.9	2.8	V
Hysteresis, V_H	0.5, 4.5	-	5	0.3	0.9	1.6	V
Input Leakage Current, I_{IN}	-	0, 5	5	-	± 0.1	± 5	μA
Three-State Output Leakage Current, I_{OUT}	0, 5	0, 5	5	-	± 0.2	± 5	μA
Input Capacitance, C_{IN}	-	-	-	-	5	7.5	pF
Output Capacitance, C_{OUT}	-	-	-	-	10	15	pF
Total Power Dissipation (Note 4)							
Run	-	-	5	-	35	50	mW
Idle "00" at M (0000)	-	-	5	-	12	18	mW
Minimum Data Retention Voltage, V_{DR}	$V_{DD} = V_{DR}$			-	2	2.4	V
Data Retention Current, I_{DR}	$V_{DD} = 2.4$			-	25	100	μA

NOTES:

3. Typical values are for $T_A = +25^{\circ}\text{C}$ and nominal V_{DD} .
4. External clock: $f = 5\text{MHz}$, $t_R, t_F = 10\text{ns}$; $C_L = 50\text{pF}$.

Dynamic Electrical Specifications at $T_A = -40^{\circ}$ to $+85^{\circ}\text{C}$; $C_L = 50\text{pF}$; Input $t_R, t_F = 10\text{ns}$; Input Pulse Levels = 0.1V to $V_{DD} - 0.1\text{V}$; $V_{DD} = 5\text{V}, \pm 5\%$.

PARAMETER	CDP1805AC CDP1806AC		UNITS
	(NOTE 5) TYP	MAX	
Propagation Delay Times			
Clock to TPA, TPB, t_{PLH}, t_{PHL}	150	275	ns
Clock-to-Memory High-Address Byte, t_{PLH}, t_{PHL}	325	550	ns
Clock-to-Memory Low-Address Byte, t_{PLH}, t_{PHL}	275	450	ns
Clock to \overline{MRD} , t_{PLH}, t_{PHL}	200	325	ns
Clock to \overline{MWR} , t_{PLH}, t_{PHL} (See Note 5)	150	275	ns
Clock to (CPU DATA to BUS), t_{PLH}, t_{PHL}	375	625	ns
Clock to State Code, t_{PLH}, t_{PHL}	225	400	ns
Clock to Q, t_{PLH}, t_{PHL}	250	425	ns
Clock to N, t_{PLH}, t_{PHL}	250	425	ns
Clock to Internal RAM Data to BUS, t_{PLH}, t_{PHL}	420	650	ns
Minimum Set-Up And Hold Times (Note 2)			

CDP1805AC, CDP1806AC

Dynamic Electrical Specifications at $T_A = -40^\circ$ to $+85^\circ\text{C}$; $C_L = 50\text{pF}$; Input $t_{R, t_F} = 10\text{ns}$; Input Pulse Levels = 0.1V to $V_{DD} - 0.1\text{V}$; $V_{DD} = 5\text{V}, \pm 5\%$. (Continued)

PARAMETER	CDP1805AC CDP1806AC		UNITS
	(NOTE 5) TYP	MAX	
Data Bus Input Set-Up, t_{SU}	-100	0	ns
Data Bus Input Hold, t_H	125	225	ns
$\overline{\text{DMA}}$ Set-Up, t_{SU}	-75	0	ns
$\overline{\text{DMA}}$ Hold, t_H	100	175	ns
$\overline{\text{ME}}$ Set-Up, t_{SU}	125	320	ns
$\overline{\text{ME}}$ Hold, t_H	0	50	ns
Interrupt Set-Up, t_{SU}	-100	0	ns
Interrupt Hold, t_H	100	175	ns
$\overline{\text{WAIT}}$ Set-Up, t_{SU}	20	50	ns
$\overline{\text{EF1-4}}$ Set-Up, t_{SU}	-125	0	ns
$\overline{\text{EF1-4}}$ Hold, t_H	175	300	ns
Minimum Pulse Width Times (Note 6)			
$\overline{\text{CLEAR}}$ Pulse Width, t_{WL}	100	175	ns
$\overline{\text{CLOCK}}$ Pulse Width, t_W	75	100	ns

NOTES:

5. Typical values are for $T_A = 25^\circ\text{C}$ and nominal V_{DD} .
6. Maximum limits of minimum characteristics are the values above which all devices function.

Timing Specifications as a function of T ($T = 1/f_{\text{CLOCK}}$) at $T_A = -40$ to $+85^\circ\text{C}$, $V_{DD} = 5\text{V}, \pm 15\%$

PARAMETER	CDP1805AC, CDP1806AC		UNITS
	TYP	(NOTE 7) MAX	
High-Order Memory-Address Byte Set-Up to TPA Time, t_{SU}	2T-275	2T -175	ns
$\overline{\text{MRD}}$ to TPA Time, t_{SU}	T/2 -100	T/2 -75	ns
High-Order Memory-Address Byte Hold after TPA Time, t_H	T/2 +75	T/2 +100	ns
Low-Order Memory-Address Byte Hold after WR Time, t_H	T +180	T +240	ns
CPU Data to Bus Hold after WR Time, t_H	T +110	T +150	ns
Required Memory Access Time, t_{ACC} Address to Data	4.5T -440	4.5T -330	ns

NOTE:

7. Typical values are for $T_A = +25^\circ\text{C}$ and nominal V_{DD} .

Timing Waveforms For Possible Operating Modes

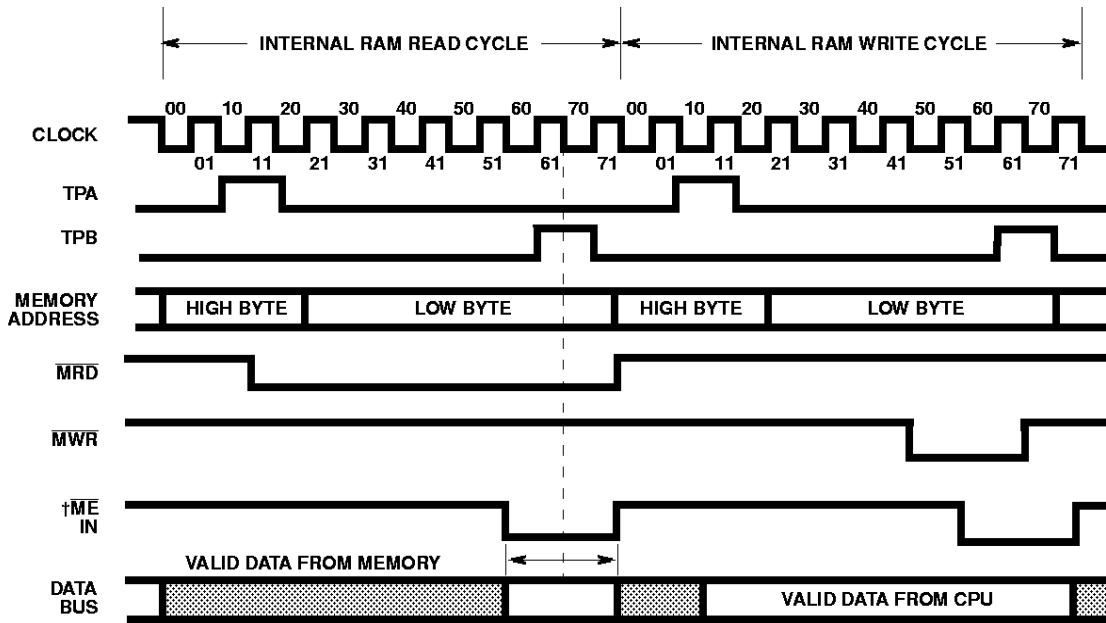

NOTE:

- ME has a minimum setup and hold time with respect to the beginning of clock 70. For a memory read operation, RAM data will appear on the data bus during the time ME is active after clock 31. The time shown can be longer, if for instance, a DMA out operation is performed on internal RAM data, to allow data enough time to be latched into an external device. The internal RAM is automatically deselected at the end of clock 71 independent of ME.

† For CDP1805AC only.

FIGURE 3. INTERNAL MEMORY OPERATION TIMING WAVEFORMS

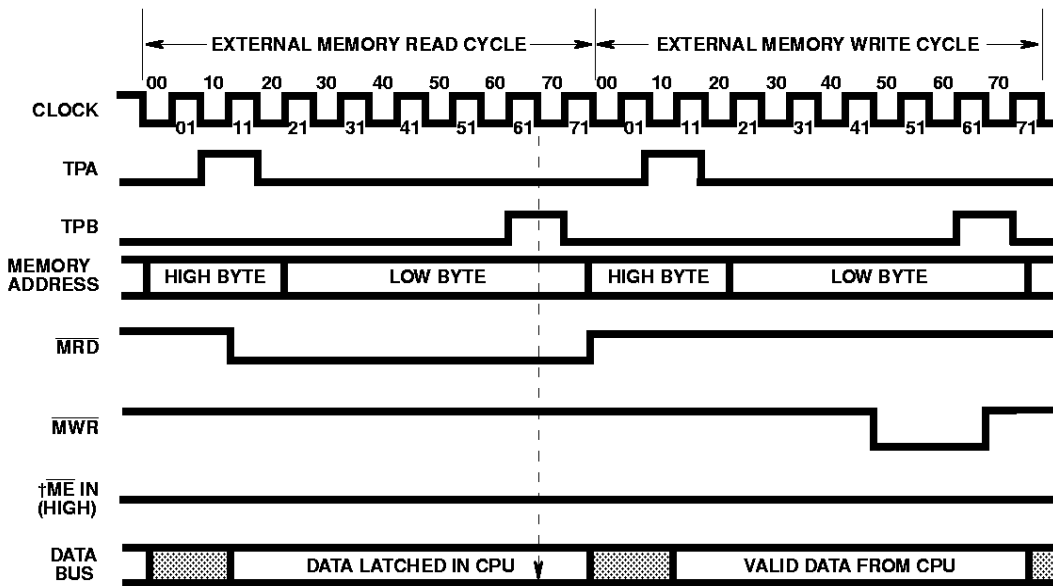

NOTE:

† For CDP1805AC only.

FIGURE 4. EXTERNAL MEMORY OPERATION TIMING WAVEFORMS

CDP1805AC, CDP1806AC

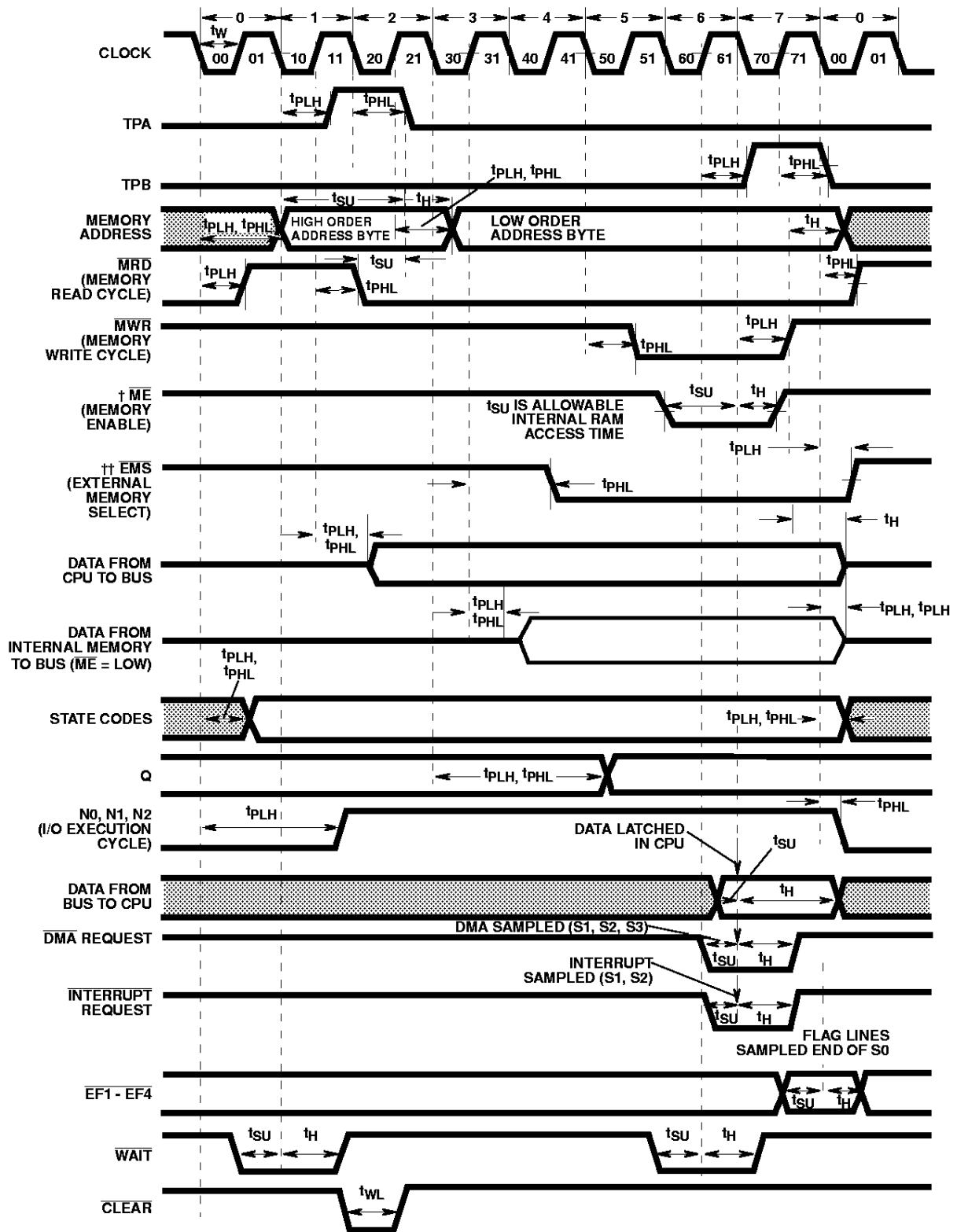

NOTES:

- † This Timing Diagram is used to show signal relationships only, and does not represent any specific machine cycle.
- † All measurements are referenced to 50% point of the wave forms.
- † Shaded areas indicate "don't care" or undefined state. Multiple transitions may occur during this period.
- † For the run (RAM only) mode only.
- †† For the run (RAM/ROM) mode only.

FIGURE 5. TIMING WAVEFORMS

Enhanced CDP1805AC and CDP1806AC Operation

Timing

Timing for the CDP1805AC and CDP1806AC is the same as the CDP1802 microprocessor series, with the following exceptions:

- 4.5 Clock Cycles Are Provided for Memory Access Instead of 5.
- Q Changes 1/2 Clock Cycle Earlier During the SEQ and REQ Instructions.
- Flag Lines ($\overline{EF1}$ - $\overline{EF4}$) Are Sampled at the End of the S0 Cycle Instead of at the Beginning of the S1 Cycle.
- Pause Can Only Occur on the Low-To-High Transition of Either TPA or TPB, Instead of any Negative Clock Transition.

Special Features

Schmitt triggers are provided on all inputs, except \overline{ME} and BUS 0-BUS 7, for maximum immunity from noise and slow signal transitions. A Schmitt Trigger in the oscillator section allows operation with an RC or crystal.

The CDP1802 Series LOAD mode is not retained. This mode (\overline{WAIT} , $\overline{CLEAR} = 0$) is not allowed on the CDP1805AC and CDP1806AC.

A low power mode is provided, which is initiated via the IDLE instruction. In this mode all external signals, except the oscillator, are stopped on the low-to-high transition of TPB. All outputs remain in their previous states, \overline{MRD} is set to a logic "1", and the data bus floats. The IDLE mode is exited by a DMA or INT condition. The INT includes both external interrupts and interrupts generated by the Counter/Timer. The only restrictions are that the Timer mode, which uses the $TPA \div 32$ clock source, and the underflow condition of the Pulse Width Measurement modes are not available to exit the IDLE mode.

Signal Descriptions

Bus 0 to Bus 7 (Data Bus)

8-Bit bidirectional DATA BUS lines. These lines are used for transferring data between the memory, the microprocessor, and I/O devices.

N0 to N2 (I/O) Lines

Activated by an I/O instruction to signal the I/O control logic of a data transfer between memory and I/O interface. These lines can be used to issue command codes or device selection codes to the I/O devices. The N-bits are low at all times except when an I/O instruction is being executed. During this time their state is the same as the corresponding bits in the N Register. The direction of data flow is defined in the I/O instruction by bit N3 (internally) and is indicated by the level of the \overline{MRD} Signal:

$\overline{MRD} = V_{DD}$: Input data from I/O to CPU and memory.

$\overline{MRD} = V_{SS}$: Output data from Memory to I/O.

$\overline{EF1}$ to $\overline{EF4}$ (4 Flags)

These inputs enable the I/O controllers to transfer status information to the processor. The levels can be tested by the conditional branch instructions. They can be used in conjunction with the INTERRUPT request line to establish interrupt priorities. The flag(s) are sampled at the end of every S0 cycle. $\overline{EF1}$ and $\overline{EF2}$ are also used for event counting and pulse width measurement in conjunction with the Counter/Timer.

$\overline{INTERRUPT}$, $\overline{DMA-IN}$, $\overline{DMA-OUT}$ (3 I/O Requests)

$\overline{DMA-IN}$ and $\overline{DMA-OUT}$ are sampled during TPB every S1, S2, and S3 cycle. $\overline{INTERRUPT}$ is sampled during TPB every S1 and S2 cycle.

Interrupt Action - X and P are stored in T after executing current instruction; designator X is set to 2; designator P is set to 1; interrupt enable (MIE) is reset to 0 (inhibit); and instruction execution is resumed. The interrupt action requires one machine cycle (S3).

DMA Action - Finish executing current instruction; R(0) points to memory area for data transfer; data is loaded into or read out of memory; and R(0) is incremented.

NOTE: In the event of concurrent DMA and INTERRUPT requests, DMA-IN has priority followed by DMA-OUT and then INTERRUPT. (The interrupt request is not internally latched and must be held true after DMA).

SC0, SC1, (2 State Code Lines)

These outputs indicate that the CPU is: 1) fetching an instruction, or 2) executing an instruction, or 3) processing a DMA request, or 4) acknowledging an interrupt request. The levels of state code are tabulated below. All states are valid at TPA.

STATE TYPE	STATE CODE LINES	
	SC1	SC0
S0 (Fetch)	L	L
S1 (Execute)	L	H
S2 (DMA)	H	L
S3 (Interrupt)	H	H

NOTE: H = V_{DD} . L = V_{SS} .

TPA, TPB (2 Timing Pulses)

Positive pulses that occurrence in each machine cycle (TPB follows TPA). They are used by I/O controllers to interpret codes and to time interaction with the data bus. The trailing edge of TPA is used by the memory system to latch the high-order byte of the multiplexed 16-bit memory address.

MA0 to MA7 (8 Memory Address Lines)

In each cycle, the higher-order byte of a 16-bit memory address appears on the memory address lines MA0-7 first. Those bits required by the memory system can be strobed into external address latches by timing pulse TPA. The low-order byte of the 16-bit address appears on the address lines 1/2 clock after the termination of TPA.

MWR (Write Pulse)

A negative pulse appearing in a memory-write cycle, after the address lines have stabilized.

MRD (Read Level)

A low level on MRD indicates a memory read cycle. It can be used to control three-state outputs from the addressed memory and to indicate the direction of data transfer during an I/O instruction.

Q

Single bit output from the CPU which can be set or reset, under program control. During SEQ and REQ instruction execution, Q is set or reset between the trailing edge of TPA and the leading edge of TPB. The Q line can also be controlled by the Counter/Timer underflow via the Enable Toggle Q instruction.

The Enable Toggle Q command connects the Q-line flip-flop to the output of the counter, such that each time the counter decrements from 01 to its next value, the Q line changes state. This command is cleared by a LOAD COUNTER (LDC) instruction with the Counter/Timer stopped, a CPU reset, or a BRANCH COUNTER INTERRUPT (BCI) instruction with the counter interrupt flip-flop set.

Clock

Input for externally generated single-phase clock. The maximum clock frequency is 5MHz at V_{DD} = 5V. The clock is counted down internally to 8 clock pulses per machine cycle.

XTAL

Connection to be used with clock input terminal, for an external crystal, if the on-chip oscillator is utilized.

WAIT, CLEAR (2 Control Lines)

Provide four control modes as listed in the following truth table:

CLEAR	WAIT	MODE
L	L	Not Allowed
L	H	Reset
H	L	Pause
H	H	Run

ME (Memory Enable CDP1805AC Only)

This active low input is used to select or deselect the internal RAM. It must be active prior to clock 70 for an internal RAM access to take place. Internal RAM data will appear on the data bus during the time that ME is active (after clock 31). Thus, if this data is to be latched into an external device (i.e., during an OUTPUT instruction or DMA OUT cycle), ME should be wide enough to provide enough time for valid data to be latched. The internal RAM is automatically deselected after clock 71. ME is ineffective when MRD • MWR = 1.

The internal RAM is not internally mask-decoded. Decoding of the starting address is performed externally, and may reside in any 64-byte block of memory.

V_{DD} (CDP1806AC Only)

This input replaces the ME signal of the CDP1805AC and must be connected to the positive power supply.

V_{DD}, V_{SS}. (Power Levels)

V_{SS} is the most negative supply voltage terminal and is normally connected to ground. V_{DD} is the positive supply voltage terminal. All outputs swing from V_{SS} to V_{DD}. The recommended input voltage swing is from V_{SS} to V_{DD}.

Architecture

Figure 2 shows a block diagram of the CDP1805AC and CDP1806AC. The principal feature of this system is a register array (R) consisting of sixteen 16-bit scratchpad registers. Individual registers in the array (R) are designated (selected) by a 4-bit binary code from one of the 4-bit registers labeled N, P, and X. The contents of any register can be directed to any one of the following paths:

1. The external memory (multiplexed, higher-order byte first on to 8 memory address lines).
2. The D register (either of the two bytes can be gated to D).
3. The increment/decrement circuit where it is increased or decreased by one and stored back in the selected 16-bit register.
4. To any other 16-bit scratch pad register in the array.

The four paths, depending on the nature of the instruction, may operate independently or in various combinations in the same machine cycle.

Most instructions consist of two 8-clock-pulse machine cycles. The first cycle is the fetch cycle, and the second, and more if necessary, are execute cycles. During the fetch cycle the four bits in the P designator select one of the 16 registers R(P) as the current program counter. The selected register R(P) contains the address of the memory location from which the instruction is to be fetched. When the instruction is read out from the memory, the higher order 4 bits of the instruction byte are loaded into the register and the lower order 4 bits into the N register. The content of the program counter is automatically incremented by one so that R(P) is now "pointing" to the next byte in the memory.

The X designator selects one of the 16 registers R(X) to "point" to the memory for an operand (or data) in certain ALU or I/O operations.

The N designator can perform the following five functions depending on the type of instruction fetched:

1. Designate one of the 16 registers in R to be acted upon during register operations.
2. Indicate to the I/O devices a command code or device-selection code for peripherals.
3. Indicate the specific operation to be executed during the ALU instructions, types of tests to be performed during the Branch instructions, or the specific operation required in a class of miscellaneous instructions.
4. Indicate the value to be loaded into P to designate a new register to be used as the program counter R(P).
5. Indicate the value to be loaded into X to designate a new register to be used as data pointer R(X).

The registers in R can be assigned by a programmer in three different ways as program counters, as data pointers, or as scratchpad locations (data registers) to hold two bytes of data.

Program Counters

Any register can be the main program counter; the address of the selected register is held in the P designator. Other registers in R can be used as subroutine program counters. By a single instruction the contents of the P register can be changed to effect a "call" to subroutine. When interrupts are being serviced, register R(1) is used as the program counter for the user's interrupt servicing routine. After reset, and during a DMA operation, R(0) is used as the program counter. At all other times the register designated as program counter is at the discretion of the user.

Data Pointers

The registers in R may be used as data pointers to indicate a location in memory. The register designated by X (i.e., R(X)) points to memory for the following instructions (see Table 1):

1. ALU operations.
2. Output instructions.
3. Input instructions.
4. Register to memory transfer.
5. Memory to register transfer.
6. Interrupt and subroutine handling.

The register designated by N (i.e., R(N)) points to memory for the "load D from memory" instructions ON and 4N and the "Store D" instruction 5N. The register designated by P (i.e., the program counter) is used as the data pointer for ALU instructions F8-FD, FF, 7C, 7D, 7F, and the RLDI instruction 68CN. During these instruction executions, the operation is referred to as "data immediate".

Another important use of R as a data pointer supports the built-in Direct-Memory-Access (DMA) function. When a DMA-In or DMA-Out request is received, one machine cycle is "stolen". This operation occurs at the end of the execute machine cycle in the current instruction. Register R(0) is always used as the data pointer during the DMA operation. The data is read from (DMA-Out) or written into (DMA-In) the memory location pointed to by the R(0) register. At the end of the transfer, R(0) is incremented by one so that the processor is ready to act upon the next DMA byte transfer request. This feature in the CDP1805AC and CDP1806AC architecture saves a substantial amount of logic when fast exchanges of blocks of data are required, such as with magnetic discs or during CRT-display-refresh cycles.

Data Registers

When registers in R are used to store bytes of data, instructions are provided which allow D to receive from or write into either the higher-order- or lower-order-byte portions of the register designated by N. By this mechanism (together with loading by data immediate) program pointer and data pointer designations are initialized. Also, this technique allows scratchpad registers in R to be used to hold general data. By employing increment or decrement instructions, such registers may be used as loop counters. The new RLDI, RLXA, RSXD, and RNX instructions also allow loading, storing, and exchanging the full 16-Bit contents of the R registers without affecting the D register. The new DBNZ instruction allows decrementing and branching-on-not-zero of any 16-Bit R register also without affecting the D register.

The Q Flip-Flop

An internal flip-flop, Q, can be set or reset by instruction and can be sensed by conditional branch instructions. It can also be driven by the underflow output of the counter/timer. The output of Q is also available as a microprocessor output.

REGISTER SUMMARY

D	8 Bits	Data Register (Accumulator)
DF	1-Bit	Data Flag (ALU Carry)
B	8 Bits	Auxiliary Holding Register
R	16 Bits	1 of 16 Scratch and Registers
P	4 Bits	Designates which Register is Program Counter
X	4 Bits	Designates which Register is Data Pointer
N	4 Bits	Holds Low-Order Instr. Digit
I	4 Bits	Holds High-Order Instr. Digit
T	8 Bits	Holds old X, P after Interrupt (X is high nibble)
Q	1-Bit	Output Flip-Flop
CNTR	8-Bits	Counter/Timer
CH	8 Bits	Holds Counter Jam Value
MIE	1-Bit	Master Interrupt Enable
CIE	1-Bit	Counter Interrupt Enable
XIE	1-Bit	External Interrupt Enable
CIL	1-Bit	Counter Interrupt Latch

Interrupt Servicing

Register R(1) is always used as the program counter whenever interrupt servicing is initialized. When an interrupt request occurs and the interrupt is allowed by the program (again, nothing takes place until the completion of the current instruction), the contents of the X and P registers are stored in the temporary Register T, and X and P are set to new values; hex digit 2 in X and hex digit 1 in P. Master Interrupt Enable is automatically deactivated to inhibit further interrupts. The user's interrupt routine is now in control; the contents of T may be saved by means of a single SAV instruction (78) in the memory location pointed to by R(X) or the contents of T, D, and DF may be saved using a single DSAV instruction (6876). At the conclusion of the interrupt, the user's routine may restore the pre-interrupted value of X and P with either a RET instruction (70) which permits further interrupts, or a DIS instruction (71), which disables further interrupts.

Interrupt Generation and Arbitration (See Figure 6)

Interrupt requests can be generated from the following sources:

1. Externally through the interrupt input (request not latched).
2. Internally due to Counter/Timer response (request is latched).
 - a. On the transition from count $(01)_{16}$ to its next value (counter underflow).
 - b. On the \nearrow transition of $\overline{EF1}$ in pulse measurement mode 1.
 - c. On the \nearrow transition of $\overline{EF2}$ in pulse measurement mode 2.

For an interrupt to be serviced by the CPU, the appropriate Interrupt Enable flip-flops must be set. Thus, the External Interrupt Enable flip-flop must be set to service an external interrupt request, and the Counter Interrupt Enable flip-flop must be set to service an internal Counter/Timer interrupt request. In addition, the Master interrupt Enable flip-flop (as used in the CDP1802) must be set to service either type of request. All 3 flip-flops are initially enabled with the application of a hardware reset, and, can be selectively enabled or disabled with software: CIE, CID instructions for the CIE flip-flop; XIE, XID instructions for the XIE flip-flop; RET, DIS instructions for the MIE flip flop.

Short branch instructions on Counter Interrupt (BCI) and External Interrupt (BXI) can be placed in the user's interrupt service routine to provide a means of identifying and prioritizing the interrupt source. Note, however, that since the External Interrupt request is not latched, it must remain active until the short branch is executed if this priority arbitration scheme is used.

Interrupt requests can also be polled if automatic interrupt service is not desired ($MIE = 0$). With the Counter Interrupt and External Interrupt short branch instructions, the branch will be taken if an interrupt request is pending, regardless of the state of any of the 3 Interrupt Enable flip-flops. The latched counter interrupt request signal will be reset when the branch is taken, when the CPU is reset, or with a LDC instruction with the Counter stopped. Note, that exiting a counter-initiated interrupt routine without resetting the counter-interrupt latch will result in immediately reentering the interrupt routine.

Counter/Timer and Controls (See Figure 7)

This logic consists of a presettable 8-Bit down-counter (Modulo N type), and a conditional divide-by-32 prescaler. After counting down to $(01)_{16}$ the counter returns to its initial value at the next count and sets the Counter Interrupt Latch. It will continue decrementing on subsequent counts. If the counter is preset to $(00)_{16}$ full 256 counts will occur.

During a Load Counter instruction (LDC) if the counter was stopped with a STPC Instruction, the counter and its holding register (CH) are loaded with the value in the D Register and any previous counter interrupt is cleared. If the LDC is executed when the counter is running, the contents of the D Register are loaded into the holding register (CH) only and any previous counter interrupt is not cleared. (LDC RESETS the Counter Interrupt Latch only when the Counter is stopped). After counting down to $(01)_{16}$ the next count will load the new initial value into the counter, set the Counter Interrupt Latch, and operation will continue.

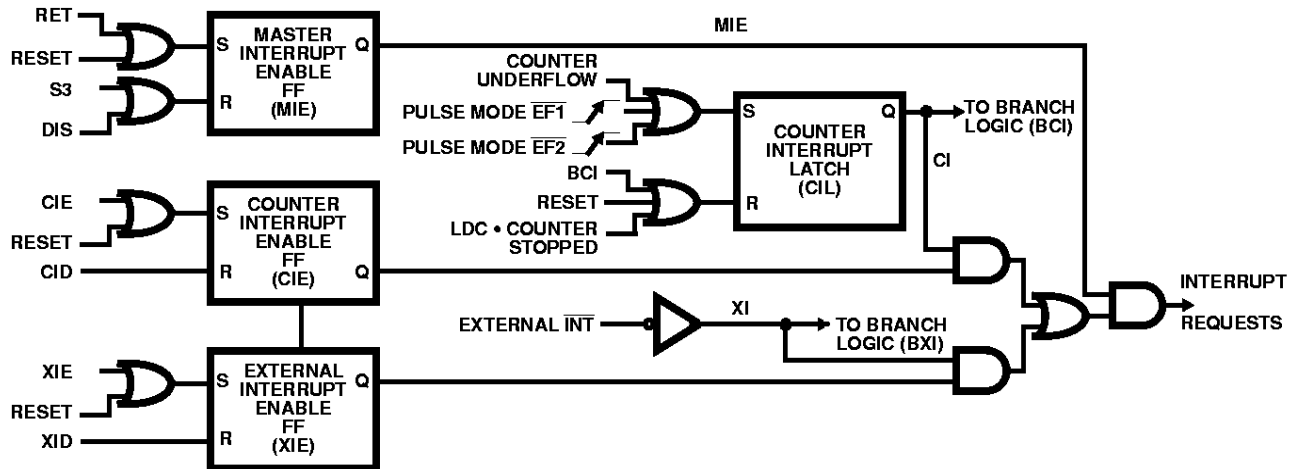

FIGURE 6. INTERRUPT LOGIC CONTROL DIAGRAM

The Counter/Timer has the following five programmable modes:

1. Event Counter 1: Input to counter is connected to the $\overline{EF1}$ terminal. The high-to-low transition decrements the counter.
2. Event Counter 2: Input to counter is connected to the $\overline{EF2}$ terminal. The high-to-low transition decrements the counter.
3. Timer: Input to counter is from the divide by 32 prescaler clocked by TPA. The prescaler is decremented on the low-to-high transition of TPA. The divide by 32 prescaler is reset when the counter is in a mode other than the Timer mode, system RESET, or stopped by a STPC.
4. Pulse Duration Measurement 1: Input to counter connected to TPA. Each low-to-high transition of TPA decrements the counter if the input signal at $\overline{EF1}$ terminal (gate input) is low. On the transition of $\overline{EF1}$ to the positive state, the count is stopped, the mode is cleared, and the interrupt request latched. If the counter underflows while the input is low, interrupt will also be set, but counting will continue.
5. Pulse Duration Measurement 2: Operation is identical to Pulse Duration Measurement 1, except $\overline{EF2}$ is used as the gate input.

The modes can be changed without affecting the stored count.

Those modes which use $\overline{EF1}$ and $\overline{EF2}$ terminals as inputs do not exclude testing these flags for branch instructions.

The Stop Counter (STPC) instruction clears the counter mode and stops counting. The STPC instruction should be executed prior to a GEC instruction, if the counter is in the Event Counter Mode 1 or 2.

In addition to the five programmable modes, the Decrement Counter instruction (DTC) enables the user to count in software. In order to avoid conflict with counting done in the other modes, the instruction should be used only after the mode has been cleared by a Stop Counter instruction.

The Enable Toggle Q instruction (ETQ) connects the Q-line flip-flop to the output of the counter, such that each time the counter decrements from 01 to its next value, the Q output changes state. This action is independent of the counter mode and the Interrupt Enable flip-flops. The Enable Toggle Q condition is cleared by an LDC with the Counter/Timer stopped, system Reset, or a BCI with CI = 1.

NOTE: SEQ and REQ instructions are independent of ETQ, they can SET or RESET Q while the Counter is running.

On-Board Clock (See Figure 8, Figure 9 and Figure 10)

Clock circuits may use either an external crystal or an RC network.

A typical crystal oscillator circuit is shown in Figure 8. The crystal is connected between terminals 1 and 39 (CLOCK and XTAL) in parallel with a resistance, R_F (1m Ω typ). Frequency trimming capacitors, C_{IN} and C_{OUT} , may be required at terminals 1 and 39. For additional information on crystal oscillators, see ICAN-6565.

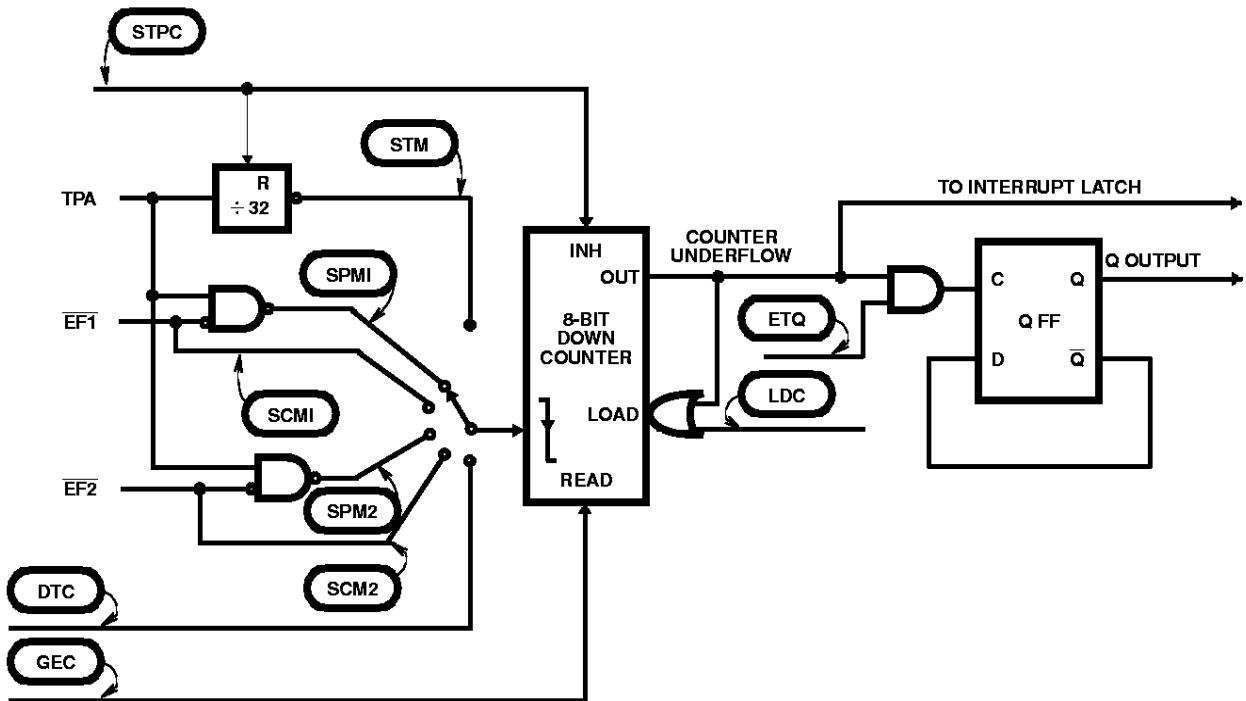
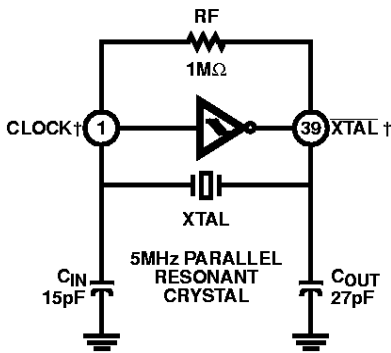

FIGURE 7. TIMER/COUNTER DIAGRAM

Because of the Schmitt Trigger input, an RC oscillator can be used as shown in Figure 9. The frequency is approximately $1/RC$ (see Figure 10).



†Pin numbers refer to 40 pin DIP.

FIGURE 8. TYPICAL 5MHz CRYSTAL OSCILLATOR

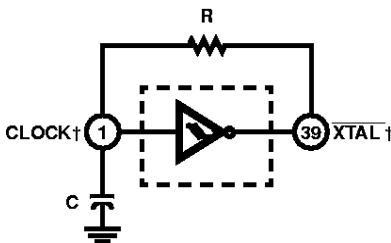

†Pin numbers refer to 40 pin DIP.

FIGURE 9. RC NETWORK FOR OSCILLATOR

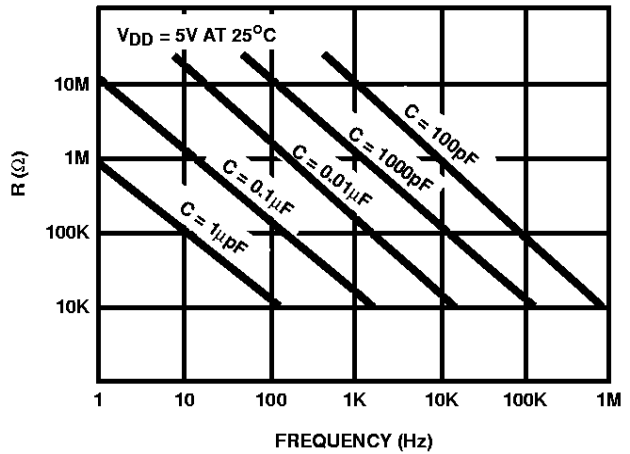

FIGURE 10. NOMINAL COMPONENT VALUES AS A FUNCTION OF FREQUENCY FOR THE RC OSCILLATOR

CONTROL MODES

CLEAR	WAIT	MODE
L	L	Not Allowed
L	H	Reset
H	L	Pause
H	H	Run

The function of the modes are defined as follows:

Reset

The levels on the CDP1805A and CDP1806A external signal lines will asynchronously be forced by RESET to the following states:

Q = 0	SC1, SC0 = 0,1	BUS 0-7 = 0
MRD = 1	(EXECUTE)	MA0-7 = RO.1
TPB = 0	N0, N1, N2 = 0, 0, 0	TPA = 0
	MWR = 1	

Internal Changes Caused By RESET are:

I, N Instruction Register is cleared to 00. XIE and CIE are set to allow interrupts following initialize. CIL is cleared (any pending counter interrupt is cleared), counter is stopped, the counter mode is cleared, and ETQ is disabled.

Initialization Cycle

The first machine cycle following termination of RESET is an initialization cycle which requires 9 clock pulses. During this cycle the CPU remains in S1 and the following additional changes occur:

1 → MIE

X, P → T (The old value of X, P will be put into T. This only has meaning following an orderly Reset with power applied).

X, P, RO ← 0 (X, P, and RO are cleared).

Interrupt and DMA servicing is suppressed during the initialization cycle. The next cycle is an S0 or an S2 but never an S1 or S3. The use of a 71 instruction followed by 00 at memory locations 0000 and 0001, may be used to reset MIE so as to preclude interrupts until ready for them.

Reset and Initialize Do Not Affect:

D (Accumulator)
 DF
 R1, R2, R3, R4, R5, R6, R7, R8, R9, FA, RB, RC, RD, RE, RF
 CH (Counter Holding Register)
 Counter (the counter is stopped but the value is unaffected)

Power-up Reset/Run Circuit

Power-up Reset/Run can be realized with the circuit shown in Figure 11.

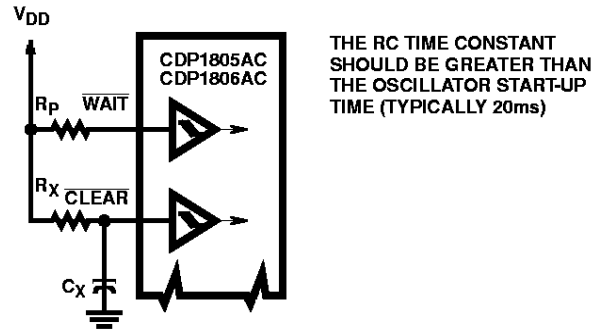

FIGURE 11. RESET/RUN DIAGRAM

Pause

Pause is a low power mode which stops the internal CPU timing generator and freezes the state of the processor. The CPU may be held in the Pause mode indefinitely. Hardware pause can occur at two points in a machine cycle, on the low-to-high transition of either TPA or TPB. A TPB pause can also be initiated by software with the execution of an IDLE instruction. In the pause mode, the oscillator continues to run but subsequent clock transitions are ignored. TPA and TPB remain at their previous state (see Figure 12).

Pause is entered from RUN by dropping WAIT low. Appropriate Setup and Hold times must be met.

If Pause is entered while in the event counter mode, the appropriate Flag transition will continue to decrement the counter.

Hardware-initiated pause is exited to RUN by raising the Wait line high. Pause entered with an IDLE instruction requires DMA, INTERRUPT or RESET to resume execution.

Run

May be initiated from the Pause or Reset mode functions. If initiated from Pause, the CPU resumes operation at the point it left off. If paused at TPA, it will resume on the next high-to-low clock transition, while if paused at TPB, it will resume on the next low-to-high clock transition (see Figure 12). When initiated from the Reset operation, the first machine cycle following Reset is always the initialization cycle. The initialization cycle is then followed by a DMA (S2) cycle or fetch (S0) from location 0000 in memory.

Schmitt Trigger Inputs

All inputs except BUS 0-BUS 7 and ME contain a Schmitt Trigger circuit, which is especially useful on the CLEAR input as a power-up RESET (see Figure 11) and the CLOCK input (see Figure 8 and Figure 9).

State Transitions

The CDP1805A and CDP1806A state transitions are shown in Figure 13. Each machine cycle requires the same period of time, 8 clock pulses, except the initialization cycle (INIT) which requires 9 clock pulses. Reset is asynchronous and can be forced at any time.

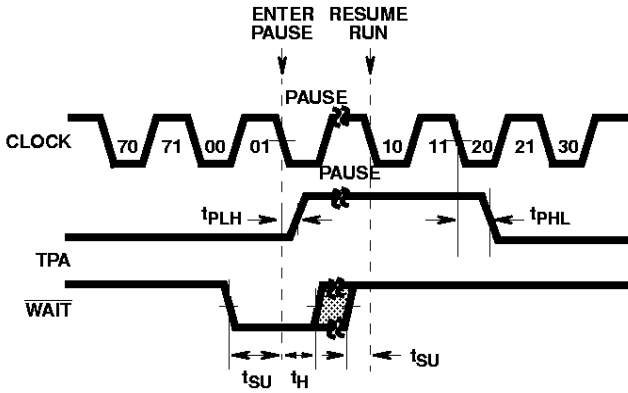
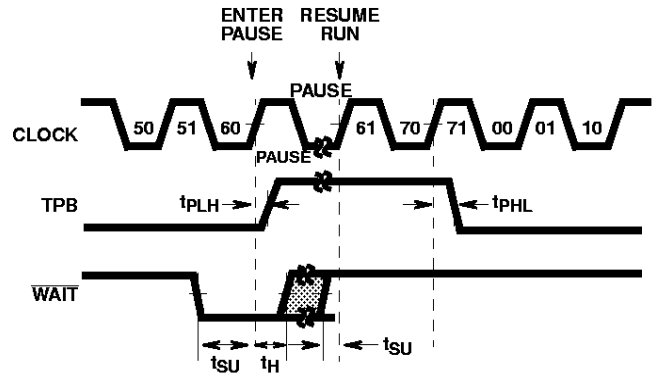

FIGURE 12A. TPA PAUSE TIMING



NOTE:

9. Pause (in clock waveform) while represented here as one clock cycle in duration, could be infinitely long.

FIGURE 12B. TPB PAUSE TIMING

FIGURE 12. PAUSE MODE TIMING WAVEFORMS

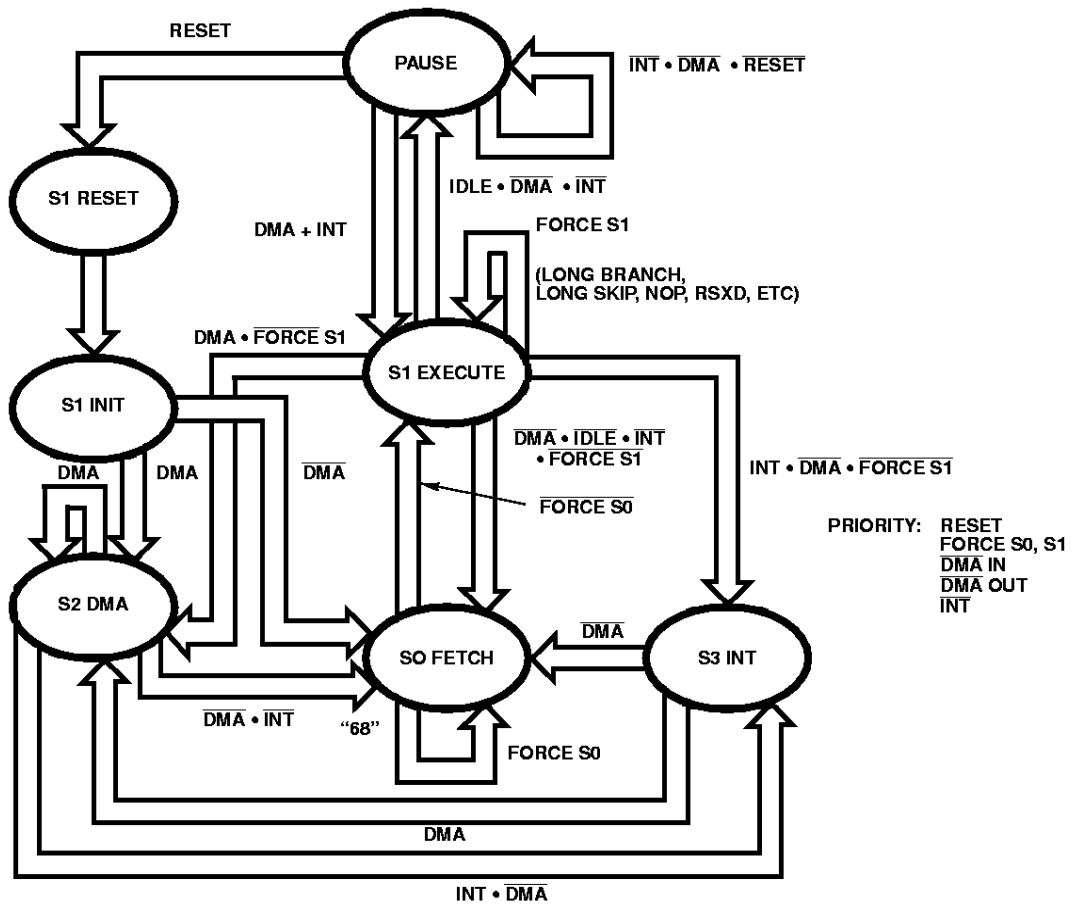

FIGURE 13. STATE TRANSITION DIAGRAM

CDP1805AC, CDP1806AC

Instruction Set

The CDP1805AC and CDP1806AC instruction summary is given in Table 1. Hexadecimal notation is used to refer to the 4-bit binary codes.

In all registers, bits are numbered from the least significant bit (LSB) to the most significant bit (MSB) starting with 0.

R(W): Register designated by W, where

W = N or X, or P

R(W).0: Lower-order byte of R(W)

R(W).1: Higher-order byte of R(W)

Operation Notation

$M(R(N)) \rightarrow D; R(N) + 1 \rightarrow R(N)$

This notation means: The memory byte pointed to by R(N) is loaded into D, and R(N) is incremented by 1.

TABLE 1. INSTRUCTION SUMMARY (SEE NOTES)

INSTRUCTION	NO. OF MACHINE CYCLES	MNEMONIC	OP CODE	OPERATION
MEMORY REFERENCE				
LOAD IMMEDIATE	2	LDI	F8	$M(R(P)) \rightarrow D; R(P) + 1 \rightarrow R(P)$
REGISTER LOAD IMMEDIATE	5	RLDI	68CN (Note 10)	$M(R(P)) \rightarrow R(N).1; M(R(P)) + 1 \rightarrow R(N).0; R(P) + 2 \rightarrow R(P)$
LOAD VIA N	2	LDN	0N	$M(R(N)) \rightarrow D; \text{FOR } N \text{ NOT } 0$
LOAD ADVANCE	2	LDA	4N	$M(R(N)) \rightarrow D; R(N) + 1 \rightarrow R(N)$
LOAD VIA X	2	LDX	F0	$M(R(X)) \rightarrow D$
LOAD VIA X AND ADVANCE	2	LDXA	72	$M(R(X)) \rightarrow D; R(X) + 1 \rightarrow R(X)$
REGISTER LOAD VIA X AND ADVANCE	5	RLXA	686N (Note 10)	$M(R(X)) \rightarrow R(N).1; M(R(X) + 1) \rightarrow R(N).0; R(X) + 2 \rightarrow R(X)$
STORE VIA N	2	STR	5N	$D \rightarrow M(R(N))$
STORE VIA X AND DECREMENT	2	STXD	73	$D \rightarrow M(R(X)); R(X) - 1 \rightarrow R(X)$
REGISTER STORE VIA X AND DECREMENT	5	RSXD	68AN (Note 10)	$R(N).0 \rightarrow M(R(X)); R(N).1 \rightarrow M(R(X) - 1); R(X) - 2 \rightarrow R(X)$
REGISTER OPERATIONS				
INCREMENT REG N	2	INC	1N	$R(N) + 1 \rightarrow R(N)$
DECREMENT REG N	2	DEC	2N	$R(N) - 1 \rightarrow R(N)$
DECREMENT REG N AND LONG BRANCH IF NOT EQUAL 0	5	DBNZ	682N	$R(N) - 1 \rightarrow R(N); \text{IF } R(N) \text{ NOT } 0, M(R(P)) \rightarrow R(P).1, M(R(P) + 1) \rightarrow R(P).0, \text{ELSE } R(P) + 2 \rightarrow R(P)$
INCREMENT REG X	2	IRX	60	$R(X) + 1 \rightarrow R(X)$
GET LOW REG N	2	GLO	8N	$R(N).0 \rightarrow D$
PUT LOW REG N	2	PLO	AN	$D \rightarrow R(N).0$
GET HIGH REG N	2	GHI	9N	$R(N).1 \rightarrow D$
PUT HIGH REG N	2	PHI	BN	$D \rightarrow R(N).1$
REGISTER N TO REGISTER X COPY	4	RNX	68BN (Note 10)	$R(N) \rightarrow R(X)$
LOGIC OPERATIONS (Note 19)				
OR	2	OR	F1	$M(R(X)) \text{ OR } D \rightarrow D$
OR IMMEDIATE	2	ORI	F9	$M(R(P)) \text{ OR } D \rightarrow D; R(P) + 1 \rightarrow R(P)$
EXCLUSIVE OR	2	XOR	F3	$M(R(X)) \text{ XOR } D \rightarrow D$
EXCLUSIVE OR IMMEDIATE	2	XRI	FB	$M(R(P)) \text{ XOR } D \rightarrow D; R(P) + 1 \rightarrow R(P)$
AND	2	AND	F2	$M(R(X)) \text{ AND } D \rightarrow D$

CDP1805AC, CDP1806AC

TABLE 1. INSTRUCTION SUMMARY (SEE NOTES) (Continued)

INSTRUCTION	NO. OF MACHINE CYCLES	MNEMONIC	OP CODE	OPERATION
AND IMMEDIATE	2	ANI	FA	$M(R(P)) \text{ AND } D \rightarrow D; R(P) + 1 \rightarrow R(P)$
SHIFT RIGHT	2	SHR	F6	Shift D Right, $LSB(D) \rightarrow DF, 0 \rightarrow MSB(D)$
SHIFT RIGHT WITH CARRY	2	SHRC	76 (Note 11)	Shift D Right, $LSB(D) \rightarrow DF, DF \rightarrow MSB(D)$
RING SHIFT RIGHT	2	RSHR	76 (Note 11)	SHIFT D RIGHT, $LSB(D) \rightarrow DF, DF \rightarrow MSB(D)$
SHIFT LEFT	2	SHL	FE	SHIFT D LEFT, $MSB(D) \rightarrow DF, 0 \rightarrow LSB(D)$
SHIFT LEFT WITH CARRY	2	SHLC	7E (Note 11)	SHIFT D LEFT, $MSB(D) \rightarrow DF, DF \rightarrow LSB(D)$
RING SHIFT LEFT	2	RSHL	7E (Note 11)	SHIFT D LEFT, $MSB(D) \rightarrow DF, DF \rightarrow LSB(D)$
ARITHMETIC OPERATIONS (Note 3)				
ADD	2	ADD	F4	$M(R(X)) + D \rightarrow DF, D$
DECIMAL ADD	4	DADD	68F4	$M(R(X)) + D \rightarrow DF, D \text{ DECIMAL ADJUST} \rightarrow DF, D$
ADD IMMEDIATE	2	ADI	FC	$M(R(P)) + D \rightarrow DF, D; R(P) + 1 \rightarrow R(P)$
DECIMAL ADD IMMEDIATE	4	DADI	68FC	$M(R(P)) + D \rightarrow DF, D; R(P) + 1 \rightarrow R(P)$ DECIMAL ADJUST $\rightarrow DF, D$
ADD WITH CARRY	2	ADC	74	$M(R(X)) + D + DF \rightarrow DF, D$
DECIMAL ADD WITH CARRY	4	DADC	6874	$M(R(X)) + D + DF \rightarrow DF, D$ DECIMAL ADJUST $\rightarrow DF, D$
ADD WITH CARRY, IMMEDIATE	2	ADCI	7C	$M(R(P)) + D + DF \rightarrow DF, D;$ $R(P) + 1 \rightarrow R(P)$
DECIMAL ADD WITH CARRY, IMMEDIATE	4	DACI	687C	$M(R(P)) + D + DF \rightarrow DF, D;$ $R(P) + 1 \rightarrow R(P);$ DECIMAL ADJUST $\rightarrow DF, D$
SUBTRACT D	2	SD	F5	$M(R(X)) - D \rightarrow DF, D$
SUBTRACT D IMMEDIATE	2	SDI	FD	$M(R(P)) - D \rightarrow DF, D;$ $R(P) + 1 \rightarrow R(P)$
SUBTRACT D WITH BORROW	2	SDB	75	$M(R(X)) - D - (\text{NOT } DF) \rightarrow DF, D$
SUBTRACT D WITH BORROW, IMMEDIATE	2	SDBI	7D	$M(R(P)) - D - (\text{NOT } DF) \rightarrow DF, D;$ $R(P) + 1 \rightarrow R(P)$
SUBTRACT MEMORY	2	SM	F7	$D - M(R(X)) \rightarrow DF, D$
DECIMAL SUBTRACT MEMORY	4	DSM	68F7	$D - M(R(X)) \rightarrow DF, D; \text{DECIMAL ADJUST} \rightarrow DF, D$
SUBTRACT MEMORY IMMEDIATE	2	SMI	FF	$D - M(R(P)) \rightarrow DF, D; R(P) + 1 \rightarrow R(P)$
DECIMAL SUBTRACT MEMORY, IMMEDIATE	4	DSMI	68FF	$D - M(R(P)) \rightarrow DF, D;$ $R(P) + 1 \rightarrow R(P);$ DECIMAL ADJUST $\rightarrow DF, D$
SUBTRACT MEMORY WITH BORROW	2	SMB	77	$D - M(R(X)) - (\text{NOT } DF) \rightarrow DF, D$
DECIMAL SUBTRACT MEMORY WITH BORROW	4	DSMB	6877	$D - M(R(X)) - (\text{NOT } DF) \rightarrow DF, D;$ DECIMAL ADJUST $\rightarrow DF, D$
SUBTRACT MEMORY WITH BORROW, IMMEDIATE	2	SMBI	7F	$D - M(R(P)) - (\text{NOT } DF) \rightarrow DF, D;$ $R(P) + 1 \rightarrow R(P)$

CDP1805AC, CDP1806AC

TABLE 1. INSTRUCTION SUMMARY (SEE NOTES) (Continued)

INSTRUCTION	NO. OF MACHINE CYCLES	MNEMONIC	OP CODE	OPERATION
DECIMAL SUBTRACT MEMORY WITH BORROW, IMMEDIATE	4	DSBI	687F	D - M(R(P)) - (NOT DF) → DF, D R(P) + 1 → R(P) DECIMAL ADJUST → DF, D
BRANCH INSTRUCTIONS - SHORT BRANCH				
SHORT BRANCH	2	BR	30	M(R(P)) → R(P).0
NO SHORT BRANCH (See SKP)	2	NBR	38 (Note 11)	R(P) + 1 → R(P)
SHORT BRANCH IF D = 0	2	BZ	32	IF D = 0, M(R(P)) → R(P).0 ELSE R(P) + 1 → R(P)
SHORT BRANCH IF D NOT 0	2	BNZ	3A	IF D NOT 0, M(R(P)) → R(P).0 ELSE R(P) + 1 → R(P)
SHORT BRANCH IF DF = 1	2	BDF	33 (Note 11)	IF DF = 1, M(R(P)) → R(P).0 ELSE R(P) + 1 → R(P)
SHORT BRANCH IF POS OR ZERO	2	BPZ	33 (Note 11)	IF DF = 1, M(R(P)) → R(P).0 ELSE R(P) + 1 → R(P)
SHORT BRANCH IF EQUAL OR GREATER	2	BGE	33 (Note 11)	IF DF = 1, M(R(P)) → R(P).0, ELSE R(P) + 1 → R(P)
SHORT BRANCH IF DF = 0	2	BNF	3B (Note 11)	IF D = 0, M(R(P)) → R(P).0, ELSE R(P) + 1 → R(P)
SHORT BRANCH IF MINUS	2	BM	3B (Note 11)	IF D = 0, M(R(P)) → R(P).0, ELSE R(P) + 1 → R(P)
SHORT BRANCH IF LESS	2	BL	3B (Note 11)	IF D = 0, M(R(P)) → R(P).0, ELSE R(P) + 1 → R(P)
SHORT BRANCH IF Q = 1	2	BQ	31	IF Q = 1, M(R(P)) → R(P).0 ELSE R(P) + 1 → R(P)
SHORT BRANCH IF Q = 0	2	BNQ	39	IF Q = 0, M(R(P)) → R(P).0 ELSE R(P) + 1 → R(P)
SHORT BRANCH IF EF1 = 1 ($\overline{EF1} = V_{SS}$)	2	B1	34	IF EF1 = 1, M(R(P)) → R(P).0 ELSE R(P) + 1 → R(P)
SHORT BRANCH IF EF1 = 0 ($\overline{EF1} = V_{DD}$)	2	BN1	3C	IF EF1 = 0, M(R(P)) → R(P).0 ELSE R(P) + 1 → R(P)
SHORT BRANCH IF EF2 = 1 ($\overline{EF2} = V_{SS}$)	2	B2	35	IF EF2 = 1, M(R(P)) → R(P).0 ELSE R(P) + 1 → R(P)
SHORT BRANCH IF EF2 = 0 ($\overline{EF2} = V_{DD}$)	2	BN2	3D	IF EF2 = 0, M(R(P)) → R(P).0 ELSE R(P) + 1 → R(P)
SHORT BRANCH IF EF3 = 1 ($\overline{EF3} = V_{SS}$)	2	B3	36	IF EF3 = 1, M(R(P)) → R(P).0 ELSE R(P) + 1 → R(P)
SHORT BRANCH IF EF3 = 0 ($\overline{EF3} = V_{DD}$)	2	BN3	3E	IF EF3 = 0, M(R(P)) → R(P).0 ELSE R(P) + 1 → R(P)
SHORT BRANCH IF EF4 = 1 ($\overline{EF4} = V_{SS}$)	2	B4	37	IF EF4 = 1, M(R(P)) → R(P).0 ELSE R(P) + 1 → R(P)
SHORT BRANCH IF EF4 = 0 ($\overline{EF4} = V_{DD}$)	2	BN4	3F	IF EF4 = 0, M(R(P)) → R(P).0 ELSE R(P) + 1 → R(P)
SHORT BRANCH ON COUNTER INTERRUPT	3	BCI	683E (Note 12)	IF CI = 1, M(R(P)) → R(P).0; 0 → CI ELSE R(P) + 1 → R(P)
SHORT BRANCH ON EXTERNAL INTERRUPT	3	BXI	683F	IF XI = 1, M(R(P)) → R(P).0 ELSE R(P) + 1 → R(P)

CDP1805AC, CDP1806AC

TABLE 1. INSTRUCTION SUMMARY (SEE NOTES) (Continued)

INSTRUCTION	NO. OF MACHINE CYCLES	MNEMONIC	OP CODE	OPERATION
BRANCH INSTRUCTIONS - LONG BRANCH				
LONG BRANCH	3	LBR	C0	$M(R(P)) \rightarrow R(P).1, M(R(P) + 1) \rightarrow R(P).0$
NO LONG BRANCH (See LSKP)	3	NLBR	C8 (Note 11)	$R(P) + 2 \rightarrow R(P)$
LONG BRANCH IF D = 0	3	LBZ	C2	IF D = 0, $M(R(P)) \rightarrow R(P).1$ $M(R(P) + 1) \rightarrow R(P).0$ ELSE $R(P) + 2 \rightarrow R(P)$
LONG BRANCH IF D NOT 0	3	LBNZ	CA	IF D NOT 0, $M(R(P)) \rightarrow R(P).1$ $M(R(P) + 1) \rightarrow R(P).0$ ELSE $R(P) + 2 \rightarrow R(P)$
LONG BRANCH IF DF = 1	3	LBDF	C3	IF DF = 1, $M(R(P)) \rightarrow R(P).1$ $M(R(P) + 1) \rightarrow R(P).0$ ELSE $R(P) + 2 \rightarrow R(P)$
LONG BRANCH IF DF = 0	3	LBNF	CB	IF DF = 0, $M(R(P)) \rightarrow R(P).1$ $M(R(P) + 1) \rightarrow R(P).0$ ELSE $R(P) + 2 \rightarrow R(P)$
LONG BRANCH IF Q = 1	3	LBQ	C1	IF Q = 1, $M(R(P)) \rightarrow R(P).1$ $M(R(P) + 1) \rightarrow R(P).0$ ELSE $R(P) + 2 \rightarrow R(P)$
LONG BRANCH IF Q = 0	3	LBNQ	C9	IF Q = 0, $M(R(P)) \rightarrow R(P).1$ $M(R(P) + 1) \rightarrow R(P).0$ ELSE $R(P) + 2 \rightarrow R(P)$
SKIP INSTRUCTIONS				
SHORT SKIP (See NBR)	2	SKP	38 (Note 11)	$R(P) + 1 \rightarrow R(P)$
LONG SKIP (See NLBR)	3	LSKP	C8 (Note 11)	$R(P) + 2 \rightarrow R(P)$
LONG SKIP IF D = 0	3	LSZ	CE	IF D = 0, $R(P) + 2 \rightarrow R(P)$ ELSE CONTINUE
LONG SKIP IF D NOT 0	3	LSNZ	C6	IF D NOT 0, $R(P) + 2 \rightarrow R(P)$ ELSE CONTINUE
LONG SKIP IF DF = 1	3	LSDF	CF	IF DF = 1, $R(P) + 2 \rightarrow R(P)$ ELSE CONTINUE
LONG SKIP IF DF = 0	3	LSNF	C7	IF DF = 0, $R(P) + 2 \rightarrow R(P)$ ELSE CONTINUE
LONG SKIP IF Q = 1	3	LSQ	CD	IF Q = 1, $R(P) + 2 \rightarrow R(P)$ ELSE CONTINUE
LONG SKIP IF Q = 0	3	LSNQ	C5	IF Q = 0, $R(P) + 2 \rightarrow R(P)$ ELSE CONTINUE
LONG SKIP IF MIE = 1	3	LSIE	CC	IF MIE = 1, $R(P) + 2 \rightarrow R(P)$ ELSE CONTINUE
CONTROL INSTRUCTIONS				
IDLE	2	IDL	00 (Note 14)	STOP ON TPB; WAIT FOR DMA OR INTERRUPT; BUS FLOATS
NO OPERATION	3	NOP	C4	CONTINUE
SET P	2	SEP	DN	$N \rightarrow P$
SET X	2	SEX	EN	$N \rightarrow X$

CDP1805AC, CDP1806AC

TABLE 1. INSTRUCTION SUMMARY (SEE NOTES) (Continued)

INSTRUCTION	NO. OF MACHINE CYCLES	MNEMONIC	OP CODE	OPERATION
SET Q	2	SEQ	7B	1 → Q
RESET Q	2	REQ	7A	0 → Q
PUSH X, P TO STACK	2	MARK	79	(X, P) → T; (X, P) → M(R(2)), THEN P → X; R(2) → 1 → R(2)
TIMER/COUNTER INSTRUCTIONS				
LOAD COUNTER	3	LDC	6806 (Note 15)	CNTR STOPPED: D → CH, CNTR; 0 → CI. CNTR RUNNING; D → CH
GET COUNTER	3	GEC	6808	CNTR → D
STOP COUNTER	3	STPC	6800	STOP CNTR CLOCK; 0 → ÷ 32 PRESCALER
DECREMENT TIMER/COUNTER	3	DTC	6801	CNTR - 1 → CNTR
SET TIMER MODE AND START	3	STM	6807	TPA ÷ 32 → CNTR
SET COUNTER MODE 1 AND START	3	SCM1	6805	EF1 → CNTR CLOCK
SET COUNTER MODE 2 AND START	3	SCM2	6803	EF2 → CNTR CLOCK
SET PULSE WIDTH MODE 1 AND START	3	SPM1	6804	TPA.EF1 → CNTR CLOCK; EF1 ↘ STOPS COUNT
SET PULSE WIDTH MODE 2 AND START	3	SPM2	6802	TPA.EF2 → CNTR CLOCK; EF2 ↘ STOPS COUNT
ENABLE TOGGLE Q	3	ETQ	6809 (Note 15)	IF CNTR = 01 • NEXT CNTR CLOCK ↘ ; Q → Q
INTERRUPT CONTROL				
EXTERNAL INTERRUPT ENABLE	3	XIE	680A	1 → XIE
EXTERNAL INTERRUPT DISABLE	3	XID	680B	0 → XIE
COUNTER INTERRUPT ENABLE	3	CIE	680C	1 → CIE
COUNTER INTERRUPT DISABLE	3	CID	680D	0 → CIE
RETURN	2	RET	70	M(R(X)) → X, P; R(X) + 1 → R(X); 1 → MIE
DISABLE	2	DIS	71	M(R(X)) → X, P; R(X) + 1 → R(X); 0 → MIE
SAVE	2	SAV	78	T → M(R(X))
SAVE T, D, DF	6	DSAV	6876 (Note 10)	R(X) - 1 → R(X), T → M(R(X)), R(X) - 1 → R(X), D → M(R(X)), R(X) - 1 → R(X), SHIFT D RIGHT WITH CARRY, D → M(R(X))
INPUT-OUTPUT BYTE TRANSFER				
OUTPUT 1	2	OUT 1	61	M(R(X)) → BUS; R(X) + 1 → R(X) N LINES = 1
OUTPUT 2	2	OUT 2	62	M(R(X)) → BUS; R(X) + 1 → R(X) N LINES = 2
OUTPUT 3	2	OUT 3	63	M(R(X)) → BUS; R(X) + 1 → R(X) N LINES = 3
OUTPUT 4	2	OUT 4	64	M(R(X)) → BUS; R(X) + 1 → R(X) N LINES = 4
OUTPUT 5	2	OUT 5	65	M(R(X)) → BUS; R(X) + 1 → R(X) N LINES = 5

CDP1805AC, CDP1806AC

TABLE 1. INSTRUCTION SUMMARY (SEE NOTES) (Continued)

INSTRUCTION	NO. OF MACHINE CYCLES	MNEMONIC	OP CODE	OPERATION
OUTPUT 6	2	OUT 6	66	$M(R(X)) \rightarrow \text{BUS}; R(X) + 1 \rightarrow R(X)$ N LINES = 6
OUTPUT 7	2	OUT 7	67	$M(R(X)) \rightarrow \text{BUS}; R(X) + 1 \rightarrow R(X)$ N LINES = 7
INPUT 1	2	INP 1	69	$\text{BUS} \rightarrow M(R(X)); \text{BUS} \rightarrow D$ N LINES = 1
INPUT 2	2	INP 2	6A	$\text{BUS} \rightarrow M(R(X)); \text{BUS} \rightarrow D$ N LINES = 2
INPUT 3	2	INP 3	6B	$\text{BUS} \rightarrow M(R(X)); \text{BUS} \rightarrow D$ N LINES = 3
INPUT 4	2	INP 4	6C	$\text{BUS} \rightarrow M(R(X)); \text{BUS} \rightarrow D$ N LINES = 4
INPUT 5	2	INP 5	6D	$\text{BUS} \rightarrow M(R(X)); \text{BUS} \rightarrow D$ N LINES = 5
INPUT 6	2	INP 6	6E	$\text{BUS} \rightarrow M(R(X)); \text{BUS} \rightarrow D$ N LINES = 6
INPUT 7	2	INP 7	6F	$\text{BUS} \rightarrow M(R(X)); \text{BUS} \rightarrow D$ N LINES = 7
CALL AND RETURN				
STANDARD CALL	10	SCAL	688N (Note 10)	$R(N).0 \rightarrow M(R(X));$ $R(N).1 \rightarrow M(R(X) - 1);$ $R(X) - 2 \rightarrow R(X); R(P) \rightarrow R(N);$ THEN $M(R(N)) \rightarrow R(P).1;$ $M(R(N) + 1) \rightarrow R(P).0;$ $R(N) + 2 \rightarrow R(N)$
STANDARD RETURN	8	SRET	689N (Note 10)	$R(N) \rightarrow R(P);$ $M(R(X) + 1) \rightarrow R(N).1;$ $M(R(X) + 2) \rightarrow R(N).0; R(X) + 2 \rightarrow R(X)$

NOTES:

10. Previous contents of T register are destroyed during instruction execution.
11. This instruction is associated with more than one mnemonic. Each mnemonic is individually listed.
12. ETQ cleared by LDC with the Counter/Timer stopped, reset of CPU, or $\text{BCI} \cdot (\text{CI} = 1)$.
13. CI = Counter Interrupt, XI = External Interrupt.
14. An IDLE instruction initiates an S1 cycle. All external signals, except the oscillator, are stopped on the low-to-high transition of TPB. All outputs remain in their previous states, MRD, MWR, are set to a logic '1' and the data bus floats. The processor will continue to IDLE until an I/O request (INTERRUPT, DMA-IN, or DMA-OUT) is activated. When the request is acknowledged, the IDLE cycle is terminated and the I/O request is serviced, and the normal operation is resumed. (To respond to an INTERRUPT during an IDLE, MIE and either CIE or XIE must be enabled).
15. Long-Branch, Long-Skip and No Op instructions require three cycles to complete (1 fetch + 2 execute).
 Long-Branch instructions are three bytes long. The first byte specifies the condition to be tested; and the second and third byte, the branching address.
 The long branch instruction can:
 - a. Branch unconditionally
 - b. Test for $D = 0$ or $D \neq 0$
 - c. Test for $DF = 0$ or $DF = 1$
 - d. Test for $Q = 0$ or $Q = 1$
 - e. Effect an unconditional no branch
 If the tested condition is met, then branching takes place; the branching address bytes are loaded in the high-and-low-order bytes of the current program counter, respectively. This operation effects a branch to any memory location.
 If the tested condition is not met, the branching address bytes are skipped over, and the next instruction in sequence is fetched and executed. This operation is taken for the case of unconditional no branch (NLBR).

16. The short-branch instructions are two or three bytes long. The first byte specifies the condition to be tested, and the second specifies the branching address, except for the branches on interrupt. For those, the first two bytes specify the condition to be tested and the third byte specifies the branching address.

The short branch instruction can:

- a. Branch unconditionally
- b. Test for D = 0 or D ≠ 0
- c. Test for DF = 0 or DF = 1
- d. Test for Q = 0 or Q = 1
- e. Test the status (1 or 0) of the four EF flags
- f. Effect an unconditional no branch
- g. Test for counter or external interrupts (BCI, BXI)

If the tested condition is met, then branching takes place; the branching address byte is loaded into the low-order byte position of the current program counter. This effects a branch within the current 256-byte page of the memory, i.e., the page which holds the branching address. If the tested condition is not met, the branching address byte is skipped over, and the next instruction in sequence is fetched and executed. This same action is taken in the case of unconditional no branch (NBR).

17. The skip instructions are one byte long. There is one Unconditional Short-Skip (SKP) and eight Long-Skip instructions.

The Unconditional Short-Skip instruction takes 2 cycles to complete (1 fetch + 1 execute). Its action is to skip over the byte following it. Then the next instruction in sequence is fetched and executed. This SKP instruction is identical to the unconditional No-Branch Instruction (NBR) except that the skipped-over byte is not considered part of the program.

The Long-Skip instructions take three cycles to complete (1 fetch + 2 execute).

They can:

- a. Skip unconditionally
- b. Test for D = 0 or D ≠ 0
- c. Test for DF = 0 or DF = 1
- d. Test for Q = 0 or Q = 1
- e. Test for MIE = 1

If the tested condition is met, then Long Skip takes place; the current program counter is incremented twice. Thus, two bytes are skipped over and the next instruction in sequence is fetched and executed. If the tested condition is not met, then no action is taken. Execution is continued by fetching the next instruction in sequence.

18. Instruction 6800 through 68FF take a minimum of 3 machine cycles and up to a maximum of 10 machine cycles. In all cases, the first two cycles are fetches and subsequent cycles are executes. The first byte (68) of these two-byte op codes is used to generate the second fetch, the second byte is then interpreted differently than the same code without the 68 prefix. DMA and INT requests are not serviced until the end of the last execute cycle.

19. Arithmetic Operations:

The arithmetic and shift operations are the only instructions that can alter the content of DF. The syntax '(NOT DF)' denotes the subtraction of the borrow.

Binary Operations:

After an ADD instruction

DF = 1 denotes a carry has occurred. Result is greater than FF₁₆.

DF = 0 denotes a carry has not occurred.

After a SUBTRACT instruction

DF = 1 denotes no borrow. D is a true positive number.

DF = 0 denotes a borrow. D is in two's complement form.

Binary Coded Decimal Operations:

After a BCD ADD instruction

DF = 1 denotes a carry has occurred. Result is greater than 99₁₀.

DF = 0 denotes a carry has not occurred.

After a BCD SUBTRACT instruction

DF = 1 denotes no borrow. D is a true positive decimal number.

Example	99	D	
	-88	M(R(X))	
	11	D	DF = 1

DF = 0 denotes a borrow. D is in ten's complement form.

Example	88	D	
	-99	M(R(X))	
	89	D	DF = 0

89 is the ten's complement of 11, which is the correct answer (with a minus value denoted by DF = 0).

CDP1805AC, CDP1806AC

TABLE 2. CONDITIONS ON DATA BUS AND MEMORY ADDRESS LINES DURING ALL MACHINE STATES

STATE	I	N	MNEMONIC	OPERATION	DATA BUS	MEMORY ADDRESS	MRD	MWR	N LINES
S1	RESET			0 → Q, I, N, COUNTER, PRESCALER, CIL; 1 → CIE, XIE	00	UNDEFINED	1	1	0
S1	INITIALIZE, NOT PROGRAMMER ACCESSIBLE			X, P → T THEN 0 → X, P; 1 → MIE, 0000 → R0	00 (Note 20)	UNDEFINED	1	1	0
S0	FETCH			MRP → I, N; RP + 1 → RP	MRP	RP	0	1	0
S1	0	0	IDL	STOP AT TPB WAIT FOR DMA OR INT	HIGH Z	RO	1	1	0
S1	0	1-F	LDN	MRN → D	MRN	RN	0	1	0
S1	1	0-F	INC	RN + 1 → RN	HIGH Z	RN	1	1	0
S1	2	0-F	DEC	RN - 1 → RN	HIGH Z	RN	1	1	0
S1	3	0-F	SHORT BRANCH	TAKEN: MRP → RP.0 NOT TAKEN: RP + 1 → RP	MRP	RP	0	1	0
S1	4	0-F	LDA	MRN → D; RN + 1 → RN	MRN	RN	0	1	0
S1	5	0-F	STR	D → MRN	D	RN	1	0	0
S1	6	0	IRX	RX + 1 → RX	MRX	RX	1	1	0
S1	6	1	OUT 1	MRX → BUS; RX + 1 → RX	MRX	RX	0	1	1
S1	6	2	OUT 2	MRX → BUS; RX + 1 → RX	MRX	RX	0	1	2
S1	6	3	OUT 3	MRX → BUS; RX + 1 → RX	MRX	RX	0	1	3
S1	6	4	OUT 4	MRX → BUS; RX + 1 → RX	MRX	RX	0	1	4
S1	6	5	OUT 5	MRX → BUS; RX + 1 → RX	MRX	RX	0	1	5
S1	6	6	OUT 6	MRX → BUS; RX + 1 → RX	MRX	RX	0	1	6
S1	6	7	OUT 7	MRX → BUS; RX + 1 → RX	MRX	RX	0	1	7
S1	6	9	INP 1	BUS → MRX, D	DATA FROM I/O DEVICE	RX	1	0	1
S1	6	A	INP 2	BUS → MRX, D	DATA FROM I/O DEVICE	RX	1	0	2
S1	6	B	INP 3	BUS → MRX, D	DATA FROM I/O DEVICE	RX	1	0	3
S1	6	C	INP 4	BUS → MRX, D	DATA FROM I/O DEVICE	RX	1	0	4
S1	6	D	INP 5	BUS → MRX, D	DATA FROM I/O DEVICE	RX	1	0	5

CDP1805AC, CDP1806AC

TABLE 2. CONDITIONS ON DATA BUS AND MEMORY ADDRESS LINES DURING ALL MACHINE STATES (Continued)

STATE	I	N	MNEMONIC	OPERATION	DATA BUS	MEMORY ADDRESS	$\overline{\text{MRD}}$	$\overline{\text{MWR}}$	N LINES
S1	6	E	INP 6	BUS \rightarrow MRX, D	DATA FROM I/O DEVICE	RX	1	0	6
S1	6	F	INP 7	BUS \rightarrow MRX, D	DATA FROM I/O DEVICE	RX	1	0	7
S1	7	0	RET	MRX \rightarrow X, P; RX + 1 \rightarrow RX 1 \rightarrow MIE	MRX	RX	0	1	0
S1	7	1	DIS	MRX \rightarrow X, P; RX + 1 \rightarrow RX 0 \rightarrow MIE	MRX	RX	0	1	0
S1	7	2	LDXA	MRX \rightarrow D; RX + 1 \rightarrow RX	MRX	RX	0	1	0
S1	7	3	STXD	D \rightarrow MRX; RX - 1 \rightarrow RX	D	RX	1	0	0
S1	7	4	ADC	MRX + D + DF \rightarrow DF, D	MRX	RX	0	1	0
S1	7	5	SDB	MRX - D - DFN \rightarrow DF, D	MRX	RX	0	1	0
S1	7	6	SHRC	LSB(D) \rightarrow DF; DF \rightarrow MSB(D)	HIGH Z	RX	1	1	0
S1	7	7	SMB	D - MRX - DFN \rightarrow DF, D	MRX	RX	0	1	0
S1	7	8	SAV	T \rightarrow MRX	T	RX	1	0	0
S1	7	9	MARK	X, P \rightarrow T, MR2; P \rightarrow X R2 - 1 \rightarrow R2	T	R2	1	0	0
S1	7	A	REQ	0 \rightarrow Q	HIGH Z	RP	1	1	0
S1	7	B	SEQ	1 \rightarrow Q	HIGH Z	RP	1	1	0
S1	7	C	ADCI	MRP + D + DF \rightarrow DF, D; RP + 1	MRP	RP	0	1	0
S1	7	D	SDBI	MRP - D - DFN \rightarrow DF, D; RP + 1	MRP	RP	0	1	0
S1	7	E	SHLC	MSB(D) \rightarrow DF; DF \rightarrow LSB D	HIGH Z	RP	1	1	0
S1	7	F	SMBI	D - MRP - DFN \rightarrow DF, D; RP + 1	MRP	RP	0	1	0
S1	8	0-F	GLO	RN.0 \rightarrow D	RN.0	RN	1	1	0
S1	9	0-F	GHI	RN.1 \rightarrow D	RN.1	RN	1	1	0
S1	A	0-F	PLO	D \rightarrow RN.0	D	RN	1	1	0
S1	B	0-F	PHI	D \rightarrow RN.1	D	RN	1	1	0
S1#1	C	0-3, 8-B	LONG BRANCH	TAKEN: MRP \rightarrow B; RP + 1 \rightarrow RP	MRP	RP	0	1	0
#2	C	0-3, 8-B	LONG BRANCH	TAKEN: B \rightarrow RP.1; MRP \rightarrow RP.0	M(RP + 1)	RP + 1	0	1	0
S1#1	C	0-3, 8-B	LONG BRANCH	NOT TAKEN RP + 1 \rightarrow RP	MRP	RP	0	1	0
#2	C	0-3, 8-B	LONG BRANCH	NOT TAKEN RP + 1 \rightarrow RP	M(RP + 1)	RP + 1	0	1	0
S1#1	C	5	LONG SKIP	TAKEN: RP + 1 \rightarrow RP	MRP	RP	0	1	0
#2	C	6	LONG SKIP	TAKEN: RP + 1 \rightarrow RP	M(RP + 1)	RP + 1	0	1	0

CDP1805AC, CDP1806AC

TABLE 2. CONDITIONS ON DATA BUS AND MEMORY ADDRESS LINES DURING ALL MACHINE STATES (Continued)

STATE	I	N	MNEMONIC	OPERATION	DATA BUS	MEMORY ADDRESS	$\overline{\text{MRD}}$	$\overline{\text{MWR}}$	N LINES
#2	C	7	LONG SKIP	TAKEN: $\text{RP} + 1 \rightarrow \text{RP}$	$\text{M}(\text{RP} + 1)$	$\text{RP} + 1$	0	1	0
S1#1	C	C	LONG SKIP	NOT TAKEN: NO OPERATION	MRP	RP	0	1	0
S1#1	C	D	LONG SKIP	NOT TAKEN: NO OPERATION	MRP	RP	0	1	0
#2	C	E	LONG SKIP	NOT TAKEN: NO OPERATION	$\text{M}(\text{RP} + 1)$	$\text{RP} + 1$	0	1	0
S1#1	C	F	LONG SKIP	NOT TAKEN: NO OPERATION	$\text{M}(\text{RP} + 1)$	$\text{RP} + 1$	0	1	0
S1#1	C	4	NOP	NO OPERATION	MRP	RP	0	1	0
#2	C	4	NOP	NO OPERATION	$\text{M}(\text{RP} + 1)$	$\text{RP} + 1$	0	1	0
S1	D	0-F	SEP	$\text{N} \rightarrow \text{P}$	NN	RN	1	1	0
S1	E	0-F	SEX	$\text{N} \rightarrow \text{X}$	NN	RN	1	1	0
S1	F	0	LDX	$\text{MRX} \rightarrow \text{D}$	MRX	RX	0	1	0
S1	F	1	OR	$\text{MRX OR D} \rightarrow \text{D}$	MRX	RX	0	1	0
S1	F	2	AND	$\text{MRX AND D} \rightarrow \text{D}$	MRX	RX	0	1	0
S1	F	3	XOR	$\text{MRX XOR D} \rightarrow \text{D}$	MRX	RX	0	1	0
S1	F	4	ADD	$\text{MRX} + \text{D} \rightarrow \text{DF}, \text{D}$	MRX	RX	0	1	0
S1	F	5	SD	$\text{MRX} - \text{D} \rightarrow \text{DF}, \text{D}$	MRX	RX	0	1	0
S1	F	7	SM	$\text{D} - \text{MRX} \rightarrow \text{DF}, \text{D}$	MRX	RX	0	1	0
S1	F	6	SHR	$\text{LSB}(\text{D}) \rightarrow \text{DF}; 0 \rightarrow \text{MSB}(\text{D})$	HIGH Z	RX	1	1	0
S1	F	8	LDI	$\text{MRP} \rightarrow \text{D}; \text{RP} + 1 \rightarrow \text{RP}$	MRP	RP	0	1	0
S1	F	9	ORI	$\text{MRP OR D} \rightarrow \text{D}; \text{RP} + 1 \rightarrow \text{RP}$	MRP	RP	0	1	0
S1	F	A	ANI	$\text{MRP AND D} \rightarrow \text{D}; \text{RP} + 1 \rightarrow \text{RP}$	MRP	RP	0	1	0
S1	F	B	XRI	$\text{MRP XOR D} \rightarrow \text{D}; \text{RP} + 1 \rightarrow \text{RP}$	MRP	RP	0	1	0
S1	F	C	ADI	$\text{MRP} + \text{D} \rightarrow \text{DF}, \text{D}; \text{RP} + 1 \rightarrow \text{RP}$	MRP	RP	0	1	0
S1	F	D	SDI	$\text{MRP} - \text{D} \rightarrow \text{DF}, \text{D}; \text{RP} + 1 \rightarrow \text{RP}$	MRP	RP	0	1	0
S1	F	F	SMI	$\text{D} - \text{MRP} \rightarrow \text{DF}, \text{D}; \text{RP} + 1 \rightarrow \text{RP}$	MRP	RP	0	1	0
S1	F	E	SHL	$\text{MSB}(\text{D}) \rightarrow \text{DF}; 0 \rightarrow \text{LSB}(\text{D})$	HIGH Z	RP	1	1	0
S2	DMA IN	DMA IN	DMA IN	$\text{BUS} \rightarrow \text{MR0}; \text{R0} + 1 \rightarrow \text{R0}$	DATA FROM I/O DEVICE	R0	1	0	0
S2	DMA OUT	DMA OUT	DMA OUT	$\text{MRO} \rightarrow \text{BUS}; \text{R0} + 1 \rightarrow \text{R0}$	MR0	R0	0	1	0
S3	INTER-RUPT	INTER-RUPT	INTERRUPT	$\text{X}, \text{P} \rightarrow \text{T}; 0 \rightarrow \text{MIE}$ $1 \rightarrow \text{P}; 2 \rightarrow \text{X}$	HIGH Z	RN	1	1	0
THE FOLLOWING ARE ALL LINKED INSTRUCTIONS "68" PRECEEDS ALL OP CODES, SO THERE IS A DUPLICATE FETCH									
S1	0	0	STPC	STOP COUNTER CLOCK; $0 \rightarrow \div 32$ PRESCALER	HIGH Z	R0	1	1	0
S1	0	1	DTC	$\text{CNTR} - 1 \rightarrow \text{CNTR}$	HIGH Z	R1	1	1	0

CDP1805AC, CDP1806AC

TABLE 2. CONDITIONS ON DATA BUS AND MEMORY ADDRESS LINES DURING ALL MACHINE STATES (Continued)

STATE	I	N	MNEMONIC	OPERATION	DATA BUS	MEMORY ADDRESS	$\overline{\text{MRD}}$	$\overline{\text{MWR}}$	N LINES
S1	0	2	SPM2	CNTR - 1 ON EF2 AND TPA	HIGH Z	R2	1	1	0
S1	0	3	SCM2	CNTR - 1 ON EF2 0 TO 1	HIGH Z	R3	1	1	0
S1	0	4	SPM1	CNTR - 1 ON EF1 AND TPA	HIGH Z	R4	1	1	0
S1	0	5	SCM1	CNTR - 1 ON EF1 0 TO 1	HIGH Z	R5	1	1	0
S1	0	6	LDC	CNTR STOPPED: D → CH, CNTR; 0 → CI CNTR RUNNING: D → CH	D	R6	1	1	0
S1	0	7	STM	CNTR - 1 ON TPA ÷ 32	HIGH Z	R7	1	1	0
S1	0	8	GEC	CNTR → D	CNTR	R8	1	1	0
S1	0	9	ETQ	IF CNTR THRU 0: \overline{Q} → Q	HIGH Z	R9	1	1	0
S1	0	A	XIE	1 → XIE	HIGH Z	RA	1	1	0
S1	0	B	XID	0 → XIE	HIGH Z	RB	1	1	0
S1	0	C	CIE	1 → CIE	HIGH Z	RC	1	1	0
S1	0	D	CID	0 → CIE	HIGH Z	RD	1	1	0
S1#1	2	0-F	DBNZ	RN - 1 → RN	HIGH Z	RN	1	1	0
#2	2	0-F	DBNZ	MRP → B; RP + 1 → RP	MRP	RP	0	1	0
#3	2	0-F	DBNZ	TAKEN: B → RP.1, MRP → RP.0 NOT TAKEN: RP + 1 → RP	M(RP + 1)	RP + 1	0	1	0
S1	3	E	BCI	TAKEN: MRP → RP.0; 0 → CI NOT TAKEN: RP + 1 → RP	MRP	RP	0	1	0
S1	3	F	BXI	TAKEN: MRP → RP.0 NOT TAKEN: RP + 1 → RP	MRP	RP	0	1	0
S1#1	6	0-F	RLXA	MRX → B, RX + 1 → RX	MRX	RX	0	1	0
#2	6	0-F	RLXA	B → T; MRX → B; RX + 1 → RX	M(RX + 1)	RX + 1	0	1	0
#3	6	0-F	RLXA	B, T → RN.0, RN.1	HIGH Z	RN	1	1	0
S1#1	7	4	DADC	MRX + D + DF → DF, D	MRX	RX	0	1	0
#2	7	4	DADC	DECIMAL ADJUST → DF, D	HIGH Z	RD	1	1	1
S1#1	7	6	DSAV	RX - 1 → RX	HIGH Z	RP	1	1	0
#2	7	6	DSAV	T → MRX; RX - 1 → RX	T	RX - 1	1	0	0
#3	7	6	DSAV	D → MRX; RX - 1 → RX SHIFT D RIGHT WITH CARRY	D	RX - 2	1	0	0
#4	7	6	DSAV	D → MRX	D	RX - 3	1	0	0
S1#1	7	7	DSMB	D - MRX - (NOT DF) → DF, D	MRX	RX	0	1	0
#2	7	7	DSMB	DECIMAL ADJUST → DF, D	HIGH Z	RP	1	1	0
S1#1	7	C	DACI	MRP + D + DF → DF, D; RP + 1 → RP	MRP	RP	0	1	0
#2	7	C	DACI	DECIMAL ADJUST → DF, D	HIGH Z	RP + 1	1	1	0
S1#1	7	F	DSBI	D - MRP - (NOT DF) → DF, D; RP + 1 → RP	MRP	RP	0	1	0

CDP1805AC, CDP1806AC

TABLE 2. CONDITIONS ON DATA BUS AND MEMORY ADDRESS LINES DURING ALL MACHINE STATES (Continued)

STATE	I	N	MNEMONIC	OPERATION	DATA BUS	MEMORY ADDRESS	$\overline{\text{MRD}}$	$\overline{\text{MWR}}$	N LINES
#2	7	F	DSBI	DECIMAL ADJUST → DF, D	HIGH Z	RP + 1	1	1	0
S1#1	8	0-F	SCAL	RN.0, RN.1 → T, B	HIGH Z	RN	1	1	0
#2	8	0-F	SCAL	T → MRX RX - 1 → RX	RN.0	RX	1	0	0
#3	8	0-F	SCAL	B → MRX RX - 1 → RX	RN.1	RX - 1	1	0	0
#4	8	0-F	SCAL	RP.0, RP.1 → T, B	HIGH Z	RP	1	1	0
#5	8	0-F	SCAL	B, T → RN.1, RN.0	HIGH Z	RN	1	1	0
#6	8	0-F	SCAL	MRN → B; RN + 1 → RN	MRP	RP	0	1	0
#7	8	0-F	SCAL	B → T; MRN → B; RN + 1 → RN	M(RP + 1)	RP + 1	0	1	0
#8	8	0-F	SCAL	B, T → RP.0, RP.1	HIGH Z	RP	1	1	0
S1#1	9	0-F	SRET	RN.0, RN.1 → T, B	HIGH Z	RN	1	1	0
#2	9	0-F	SRET	RX + 1 → RX	HIGH Z	RX	1	1	0
#3	9	0-F	SRET	B, T → RP.1, RP.0	HIGH Z	RP	1	1	0
#4	9	0-F	SRET	MRX → B; RX + 1 → RX	M(RX + 1)	RX + 1	0	1	0
#5	9	0-F	SRET	B → T; MRX → B	M(RX + 1)	RX + 2	0	1	0
#6	9	0-F	SRET	B, T → RN.0, RN.1	HIGH Z	RN	1	1	0
S1#1	A	0-F	RSXD	RN.0, RN.1 → T, B	HIGH Z	RN	1	1	0
#2	A	0-F	RSXD	T → MRX; RX - 1 → RX	RN.0	RX	1	0	0
#3	A	0-F	RSXD	B → MRX; RX - 1 → RX	RN.1	RX - 1	1	0	0
S1#1	B	0-F	RNX	RN.0, RN.1 → T, B	HIGH Z	RN	1	1	0
#2	B	0-F	RNX	B, T → RX.1, RX.0	HIGH Z	RX	1	1	0
S1#1	C	0-F	RLDI	MRP → B; RP + 1 → RP	MRP	RP	0	1	0
#2	C	0-F	RLDI	B → T; MRP → B; RP + 1 → RP	M(RP + 1)	RP + 1	0	1	0
#3	C	0-F	RLDI	B, T → RN.0, RN.1; RP + 1 → RP	HIGH Z	RN	1	1	0
S1#1	F	4	DADD	MRX + D → DF; D	MRX	RX	0	1	0
#2	F	4	DADD	DECIMAL ADJUST → DF, D	HIGH Z	RP	1	1	0
S1#1	F	7	DSM	D - MRX → DF, D	MRX	RX	0	1	0
#2	F	7	DSM	DECIMAL ADJUST → DF, D	HIGH Z	RP	1	1	0
S1#1	F	C	DADI	MRP + D → DF, D; RP + 1 → RP	MRP	RP	0	1	0
#2	F	C	DADI	DECIMAL ADJUST → DF, D	HIGH Z	RP + 1	1	1	0
S1#1	F	F	DSMI	D - MRP → DF, D RP + 1 → RP	MRP	RP	0	1	0
#2	F	F	DSMI	DECIMAL ADJUST → DF, D	HIGH Z	RP + 1	1	1	0

NOTE:

20. Data bus floats for first 2-1/2 clocks of the nine clock initialization cycle; all zeros for remainder of cycle.

CDP1805AC, CDP1806AC

INSTRUCTION SUMMARY

N																	
	0	1	2	3	4	5	6	7	8	9	A	B	C	D	E	F	
0	IDL	LDN															
1	INC																
2	DEC																
3	BR	BQ	BZ	BDF	B1	B2	B3	B4	SKP	BNQ	BNZ	BNF	BN1	BN2	BN3	BN4	
4	LDA																
5	STR																
6	IRX	OUT							†	INP							
7	RET	DIS	LDXA	STXD	ADC	SDB	SHRC	SMB	SAV	MARK	REQ	SEQ	ADCI	SDBI	SHLC	SMBI	
8	GLO																
9	GHI																
A	PLO																
B	PHI																
C	LBR	LBQ	LBZ	LBDF	NOP	LSNQ	LSNZ	LSNF	LSKP	LBNQ	LBNZ	LBNF	LSIE	LSQ	LSZ	LSDF	
D	SEP																
E	SEX																
F	LDX	OR	AND	XOR	ADD	SD	SHR	SM	LDI	ORI	ANI	XRI	ADI	SDI	SHL	SMI	
'68' LINKED OPCODES (DOUBLE FETCH)																	
0	STPC	DTC	SPM2	SCM2	SPM1	SCM1	LDC	STM	GEC	ETQ	XIE	XID	CIE	CID	-	-	
2	DBNZ																
3	-	-	-	-	-	-	-	-	-	-	-	-	-	-	BCI	BXI	
6	RLXA																
7	-	-	-	-	DADC	-	DSAV	DSMB	-	-	-	-	DACI	-	-	DSBI	
8	SCAL																
9	SRET																
A	RSXD																
B	RNX																
C	RLDI																
F	-	-	-	-	DADD	-	-	DSM	-	-	-	-	DADI	-	-	DSMI	

†'68' is used as a linking OPCODE for the double fetch instructions.

Operating and Handling Considerations

Handling

All inputs and outputs of Harris CMOS devices have a network for electrostatic protection during handling.

Operating

Operating Voltage

During operation near the maximum supply voltage limit, care should be taken to avoid or suppress power supply turn-on and turn-off transients, power supply ripple, or ground noise; any of these conditions must not cause $V_{DD} - V_{SS}$ to exceed the absolute maximum rating.

Input Signals

To prevent damage to the input protection circuit, input signals should never be greater than V_{DD} nor less than V_{SS} . Input currents must not exceed 10mA even when the power supply is off.

Unused Inputs

A connection must be provided at every input terminal. All unused input terminals must be connected to either V_{DD} or V_{SS} , whichever is appropriate.

Output Short Circuits

Shorting of outputs to V_{DD} or V_{SS} may damage CMOS devices by exceeding the maximum device dissipation.