

Rochester Electronics Manufactured Components

Rochester branded components are manufactured using either die/wafers purchased from the original suppliers or Rochester wafers recreated from the original IP. All recreations are done with the approval of the OCM.

Parts are tested using original factory test programs or Rochester developed test solutions to guarantee product meets or exceed the OCM data sheet.

Quality Overview

- ISO-9001
- AS9120 certification
- Qualified Manufacturers List (QML) MIL-PRF-35835
 - Class Q Military
 - Class V Space Level
- Qualified Suppliers List of Distributors (QSLD)
 - Rochester is a critical supplier to DLA and meets all industry and DLA standards.

Rochester Electronics, LLC is committed to supplying products that satisfy customer expectations for quality and are equal to those originally supplied by industry manufacturers.

The original manufacturer's datasheet accompanying this document reflects the performance and specifications of the Rochester manufactured version of this device. Rochester Electronics guarantees the performance of its semiconductor products to the original OEM specifications. 'Typical' values are for reference purposes only. Certain minimum or maximum ratings may be based on product characterization, design, simulation, or sample testing.

Am8T26A·Am8T28

Schottky Three-State Quad Bus Driver/Receiver

Distinctive Characteristics

- Advanced Schottky technology
- 48mA driver sink current
- Three-state outputs on driver and receiver
- PNP inputs
- Am8T26A has inverting outputs
- Am8T28 has non-inverting outputs
- Driver propagation delay — 14ns max. for 8T26A; 17ns max. for 8T28
- Receiver propagation delay — 14ns max. for 8T26A; 17ns max. for 8T28
- 100% reliability assurance testing in compliance with MIL-STD-883

FUNCTIONAL DESCRIPTION

The Am8T26A/Am8T28 are high speed bus transceivers consisting of four bus drivers with three-state outputs and four bus receivers, also with three-state outputs. Each driver output is internally connected to a receiver input. Both the drivers and receivers have PNP inputs.

One buffered common "bus enable" input is connected to the four drivers and another buffered common "receiver enable" input is connected to the receivers. A LOW on the bus enable (B/E) input forces the four driver outputs to the high-impedance state. A HIGH on the bus enable allows input data to be transferred onto the data bus.

A HIGH on the receiver enable (R/E) input forces the four receiver outputs to the high-impedance state while a LOW on the receiver enable input allows the received data to be transferred to the output. The complementary design of the bus enable and receiver enable inputs allows these control inputs to be connected together externally such that a single transmit/receive function is derived.

LOGIC SYMBOL

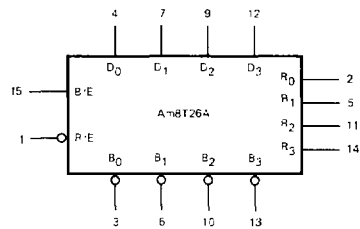

V_{CC} = Pin 16
GND = Pin 8

LIC-561

LOGIC DIAGRAMS

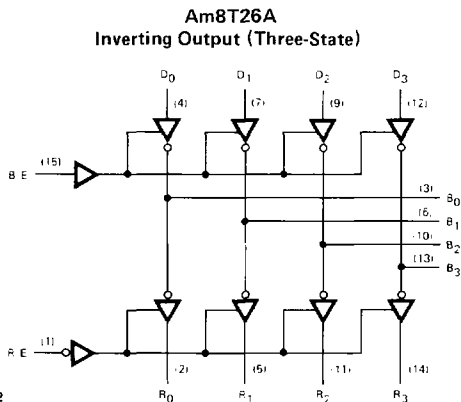

LIC-562

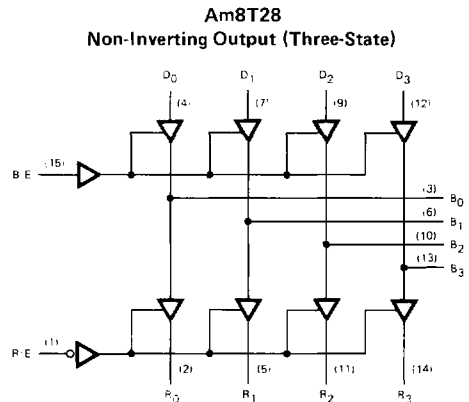

LIC-563

ORDERING INFORMATION

Package Type	Temperature Range	Am8T26A Order Number	Am8T28 Order Number
Molded DIP	0°C to +75°C	N8T26AB	N8T28B
Hermetic DIP	0°C to +75°C	N8T26AF	N8T28F
Dice	0°C to +75°C	AM8T26AXC	AM8T28XC
Hermetic DIP	-55°C to +125°C	S8T26AF	S8T28F
Dice	-55°C to +125°C	AM8T26AXM	AM8T28XM

CONNECTION DIAGRAM (Top View)

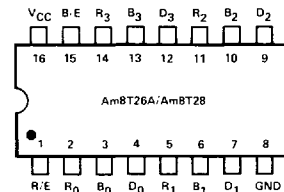

Note: Pin 1 is marked for orientation.

LIC-564

MAXIMUM RATINGS (Above which the useful life may be impaired)

Storage Temperature	-65°C to +150°C
Temperature (Ambient) Under Bias	-55°C to +125°C
Supply Voltage to Ground Potential (Pin 16 to Pin 8) Continuous	-0.5V to +7V
DC Voltage Applied to Outputs for HIGH Output State	-0.5V to +V _{CC} max.
DC Input Voltage	-0.5V to +5.5V
DC Output Current, Into Outputs (Receiver)	30mA
DC Output Current, Into Outputs (BUS)	80mA
DC Input Current	-30mA to +5.0mA

ELECTRICAL CHARACTERISTICS OVER OPERATING TEMPERATURE RANGE

The Following Conditions Apply Unless Otherwise Noted:

N8T26A, N8T28 T_A = 0°C to +75°C (COM'L) MIN. = 4.75V MAX. = 5.25V
 S8T26A, S8T28 T_A = -55°C to +125°C (MIL) MIN. = 4.50V MAX. = 5.50V

DC CHARACTERISTICS OVER OPERATING TEMPERATURE RANGE

Parameters	Description	Test Conditions (Note 1)	Min.	Typ. (Note 2)	Max.	Units
Driver						
I _{IL}	Low Level Input Current	V _{IN} = 0.4V			-200	μA
I _{IL}	Low Level Input Current (Disabled)	V _{IN} = 0.4V			-25	μA
I _{IH}	High Level Input Current (D _{IN} , D _E)	V _{IN} = V _{CC} MAX.			25	μA
V _{OL}	Low Level Output Voltage	I _{OUT} = 48mA (Note 5)			0.5	Volts
V _{OH}	High Level Output Voltage	I _{OUT} = -10mA, V _{CC} = V _{CC} MIN. (Note 6)	2.4			Volts
I _{OS}	Short Circuit Output Current	V _{OUT} = 0V, V _{CC} = V _{CC} MAX. (Note 4)	-50		-150	mA
Receiver						
I _{IL}	Low Level Input Current	V _{IN} = 0.4V			-200	μA
I _{IH}	High Level Input Current (R _E)	V _{IN} = V _{CC} MAX.			25	μA
V _{OL}	Low Level Output Voltage	I _{OUT} = 20mA (Note 5)			0.5	Volts
V _{OH}	High Level Output Voltage	I _{OUT} = -100μA, V _{CC} = 5.0V	3.5			Volts
		I _{OUT} = -2.0mA (Note 6)	2.4			
I _{OS}	Short Circuit Output Current	V _{OUT} = 0V, V _{CC} = V _{CC} MAX.	-30		-75	mA
Both Driver and Receiver						
V _{TL}	Low Level Input Threshold Voltage		0.85			Volts
V _{TH}	High Level Input Threshold Voltage				2.0	Volts
I _O	Low Level Output Off Leakage Current	V _{OUT} = 0.5V			-100	μA
	High Level Output Off Leakage Current	V _{OUT} = 2.4V			100	
V _I	Input Clamp Voltage	I _{IN} = -12mA			-1.0	Volts
P _{WR} / I _{CC}	Power/Current Consumption	Am8T26A	V _{CC} = V _{CC} MAX.		457/87	mW/mA
		Am8T28	V _{CC} = V _{CC} MAX.		578/110	

4

Switching Characteristics (T_A = +25°C, V_{CC} = 5.0V)

Parameters	Description	Test Conditions	Am8T26A			Am8T28			Units
			Min.	Typ.	Max.	Min.	Typ.	Max.	
t _{PLH}	Driver Input to Bus	Figure 1		10	14		13	17	ns
t _{PHL}				10	14		13	17	
t _{PLH}	Bus to Receiver Output	Figure 2		9.0	14		12	17	ns
t _{PHL}				6.0	14		9.0	17	
t _{ZL}	Driver Enable to Bus	Figure 3		19	25		21	28	ns
t _{LZ}				15	20		18	23	
t _{ZL}	Receiver Enable to Receiver Output	Figure 4		15	20		18	23	ns
t _{LZ}				10	15		13	18	

Notes: 1. For conditions shown as MIN. or MAX., use the appropriate value specified under Electrical Characteristics for the applicable device type.

2. Typical limits are at V_{CC} = 5.0V, 25°C ambient and maximum loading.

3. Actual input currents = Unit Load Current x Input Load Factor (See Loading Rules).

4. Not more than one output should be shorted at a time. Duration of the short circuit test should not exceed one second.

5. Output sink current is supplied through a resistor to V_{CC}.

6. Measurements apply to each output and the associated data input independently.

DEFINITION OF FUNCTIONAL TERMS

D₀, D₁, D₂, D₃ The four driver inputs.

B₀, B₁, B₂, B₃ The four driver outputs and receiver inputs (data is inverted).

R₀, R₁, R₂, R₃ The four receiver outputs. Data from the bus is inverted while data from the driver inputs is non-inverted.

B/E Bus enable input. When the bus enable input is LOW, the four driver outputs are in the high-impedance state.

R/E Receiver enable input. When the receiver enable input is HIGH, the four receiver outputs are in the high-impedance state.

LOADING RULES (In Unit Loads)

Input/Output	Pin No.'s	LOW Input Unit Load	Fan-out Output HIGH	Output LOW
R/E	1	1/8	—	—
R ₀	2	—	50	10
B ₀	3	1/16	250	25
D ₀	4	1/8	—	—
R ₁	5	—	50	10
B ₁	6	1/16	250	25
D ₁	7	1/8	—	—
GND	8	—	—	—
D ₂	9	1/8	—	—
B ₂	10	1/16	250	25
R ₂	11	—	50	10
D ₃	12	1/8	—	—
B ₃	13	1/16	250	25
R ₃	14	—	50	10
B/E	15	1/8	—	—
V _{CC}	16	—	—	—

A TTL Unit Load is defined as -1.6mA measured at 0.4V LOW and 40μA measured at 2.4V HIGH.

DRIVER FUNCTION TABLE

INPUTS		Am8T26A OUTPUT	Am8T28 OUTPUT
B/E	D _i	B _i	B _j
L	X	Z	Z
H	L	H	L
H	H	L	H

L = LOW
H = HIGH
i = 0, 1, 2, or 3
X = Don't Care
Z = High Impedance

RECEIVER FUNCTION TABLE

INPUTS		Am8T26A OUTPUT	Am8T28 OUTPUT
R/E	B _i	R _i	R _j
H	X	Z	Z
L	L	H	L
L	H	L	H

L = LOW
H = HIGH
i = 0, 1, 2, or 3
X = Don't Care
Z = High Impedance

INPUT/OUTPUT CURRENT INTERFACE CONDITIONS

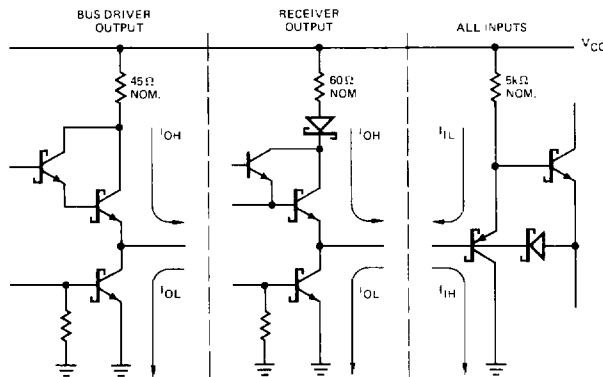

Note: Actual current flow direction shown.

LIC-565

AC TEST CIRCUITS AND WAVEFORMS

PROPAGATION DELAY (Data In to Bus)

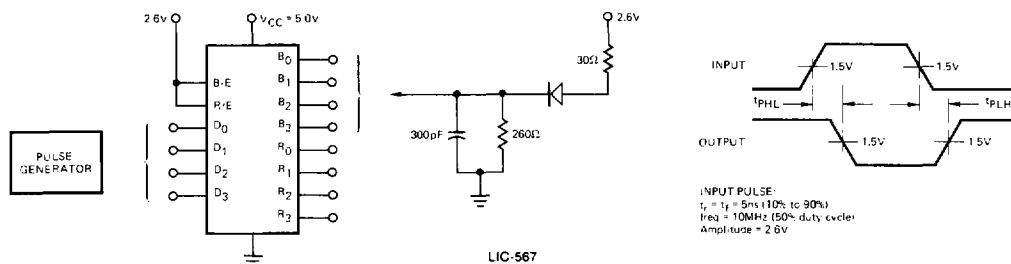

LIC-566

Figure 1

LIC-568

PROPAGATION DELAY (Bus to Receiver Out)

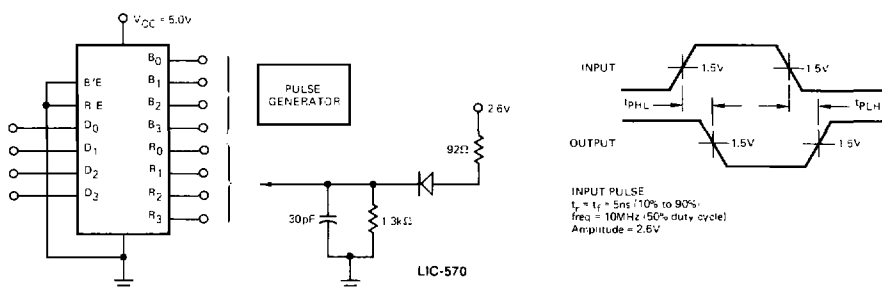

LIC-569

Figure 2

LIC-571

PROPAGATION DELAY (Bus Enable to Bus Output)

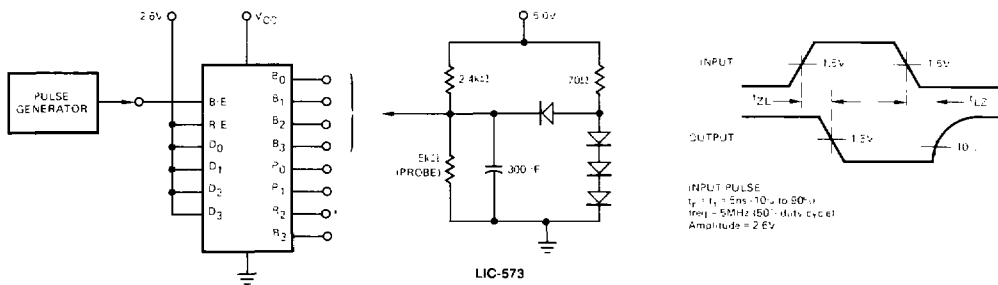

LIC-572

Figure 3

LIC-574

PROPAGATION DELAY (Receive Enable to Receive Output)

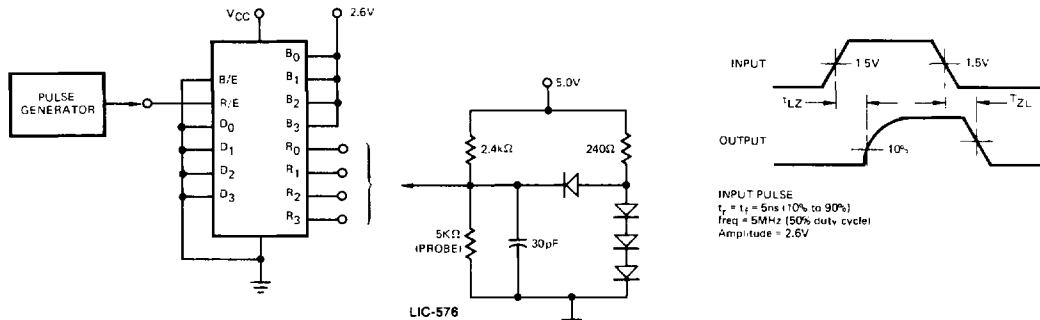

LIC-575

Figure 4

LIC-577

4

APPLICATION

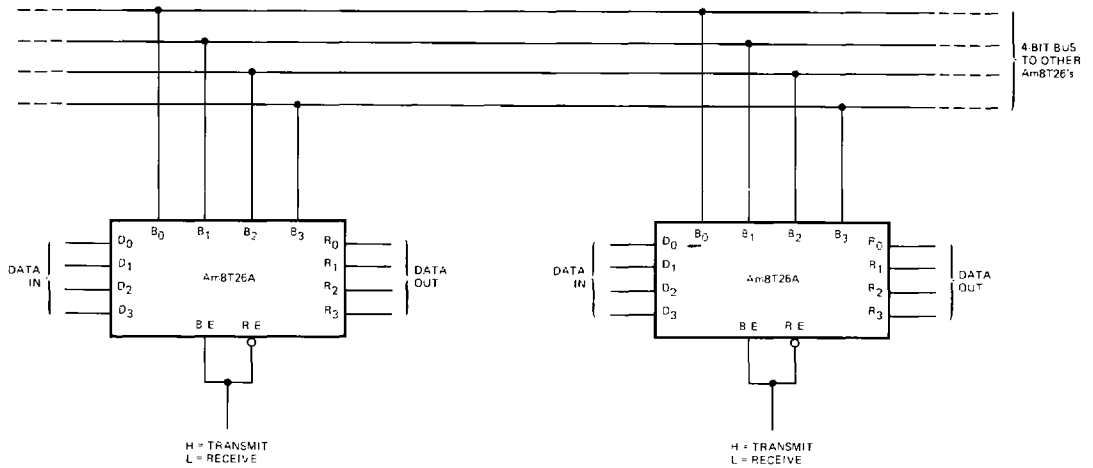

LIC-578

Metallization and Pad Layouts

Am8T26A

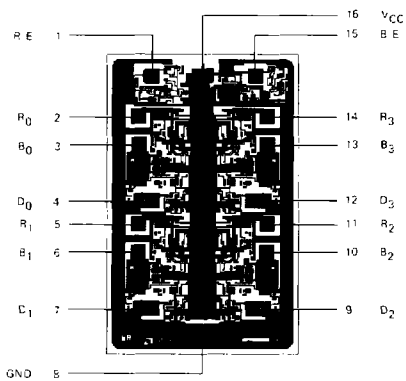

DIE SIZE 0.058" X 0.091"

Am8T28

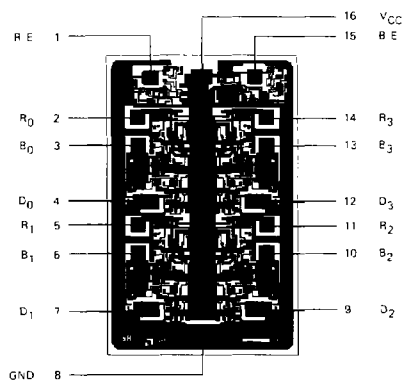

DIE SIZE 0.058" X 0.091"