

# DC Brushless Fan Motor Drivers

## Three-Phase Full-Wave Fan Motor Driver



### BH67172NUX

#### ●General description

BH67172UX is a three-phase sensorless fan motor driver used to cool off notebook PCs. It is controlled by a variable speed provided through the PWM input signal. Its feature is sensorless drive which doesn't require a hall device as a location detection sensor and motor downsizing can be achieved by limiting the number of external components as much as possible. Furthermore, introducing a direct PWM soft switched driving mechanism achieves silent operations and low vibrations.

#### ●Features

- Speed controllable by PWM input signal
- Sensorless drive
- Soft switched drive Quick start
- Power save function
- Internal RNF resistance
- Quick start function

#### ●Application

- Small fan motor notebook PCs etc.

#### ●Package

VSON010X3030

W (Typ.) x D (Typ.) x H (Max.)  
3.00mm x 3.00mm x 0.60mm



#### ●Absolute maximum ratings

Parameter	Symbol	Limit	Unit
Supply voltage	VCC	-0.3~6.5	V
Power dissipation	Pd	464 <sup>*1</sup>	mW
Operating temperature	Topr	-25 to +95	°C
Storage temperature	Tstg	-55 to +125	°C
Output current	Iomax	700 <sup>*2</sup>	mA
FG signal output voltage	VFG	6.5	V
FG signal output current	IFG	6	mA
Junction temperature	Tjmax	125	°C

\*1 Reduce by 4.64mW/°C over Ta=25°C. (On 74.2mmx74.2mmx1.6mm glass epoxy board)

\*2 This value is not to exceed Pd.

#### ●Recommended operating conditions

Parameter	Symbol	Limit	Unit
Operating supply voltage range	VCC	1.8 to 5.5	V

●Pin configuration

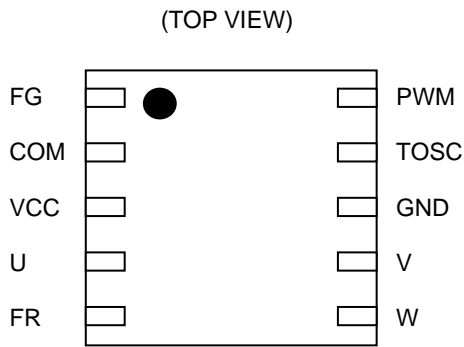

Fig.1 Pin configuration

●Pin description

P/No.	T/name	機能
1	FG	FG output terminal
2	COM	Coil midpoint terminal
3	VCC	Power supply terminal
4	U	U phase output terminal
5	FR	Forward/Reverse switch terminal
6	W	W phase output terminal
7	V	V phase output terminal
8	GND	GND terminal
9	TOSC	Start-up oscillation terminal
10	PWM	PWM signal input terminal

Block diagram

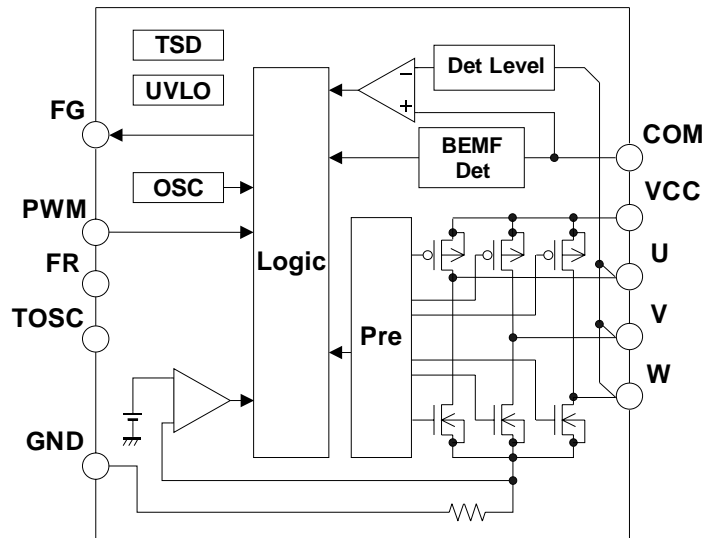

Fig.2 Block diagram

## Electrical characteristics (Unless otherwise specified VCC=5V, Ta=25°C)

Parameter	Symbol	Limit			Unit	Conditions
		Min.	Typ.	Max.		
Circuit current STB	ICST	-	20	50	uA	
Circuit current	ICC	2.0	4.5	7.0	mA	
PWM input H level	VPH	2.5	-	VCC	V	
PWM input L level	VPL	0	-	0.7	V	
PWM input current H	IPH	-	0	1	uA	PWM=VCC
PWM input current L	IPL	-50	-20	-	uA	PWM=GND
Input frequency	FP	20	-	50	kHz	
FR input H level	VFRH	2.5	-	VCC	V	FR=H : Forward drive
FR input L level	VFRL	0	-	0.5	V	FR=L : Reverse drive
TOSC charge current	OCC	-125	-100	-67	uA	TOSC=0.5V
TOSC discharge current	ODC	67	100	125	uA	TOSC=1.0V
TOSC frequency	OSF	27	38	49	kHz	TOSC-GND 2200pF
PWM off time	TPO	500	1000	2000	us	
Output voltage	VO	-	0.25	0.325	V	Io=250mA (H.L. total)
FG low voltage	VFGL	-	-	0.4	V	IFG=5mA
Lock protection det.time	LDT	-	0.5	1.0	s	
Lock protection rel.time	LRT	2.5	5	10	s	
Lock protection ratio	RLT	9	10	-	-	rel.time/det.time ratio

About a current item, define the inflow current to IC as a positive notation, and the outflow current from IC as a negative notation.

● Typical performance curves(Reference data)

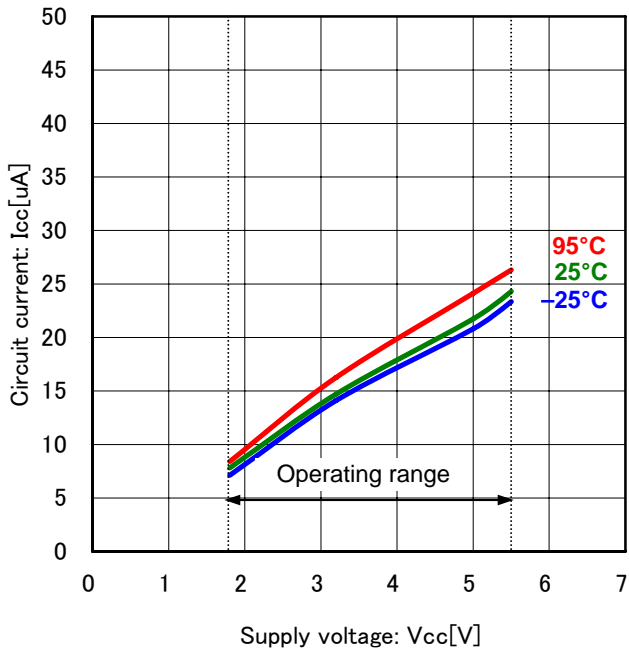

Fig.3 Circuit current

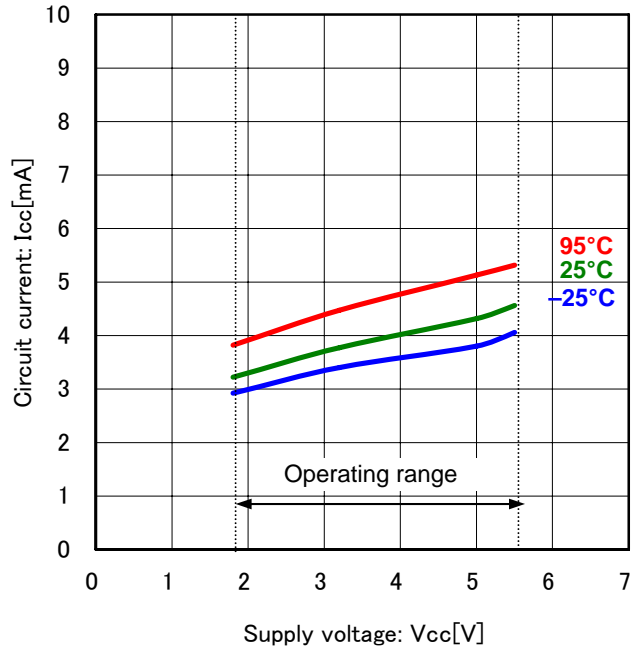

Fig.4 Circuit current STB

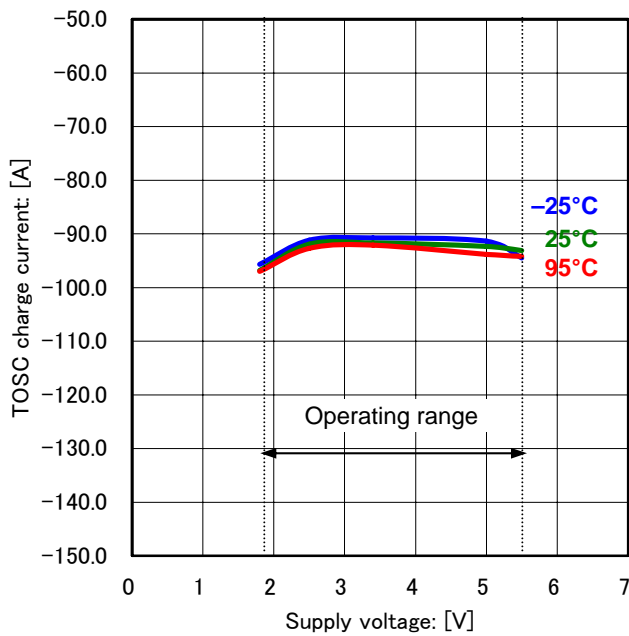

Fig.5 TOSC charge current

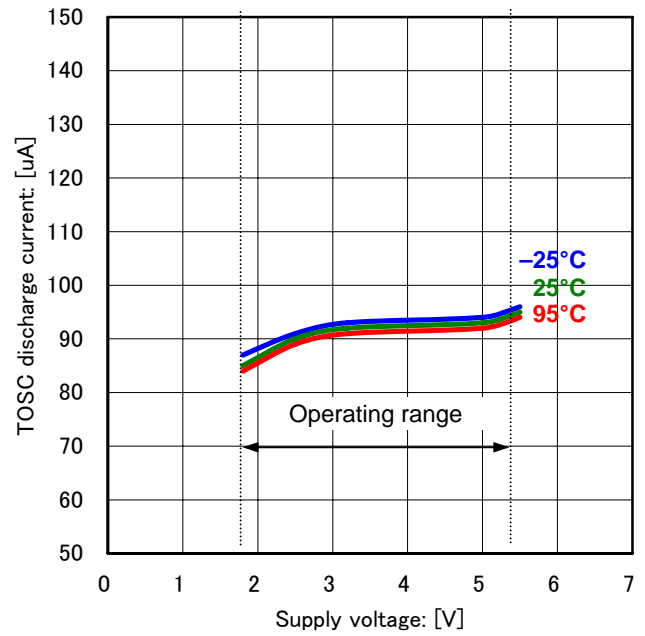

Fig.6 TOSC discharge current

● Typical performance curves(Reference data)

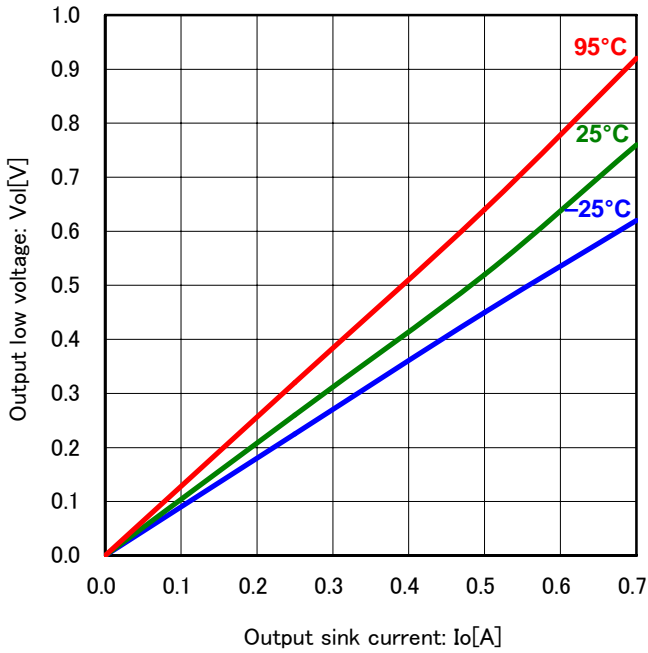

Fig.7 Output voltage (Vcc=5V)

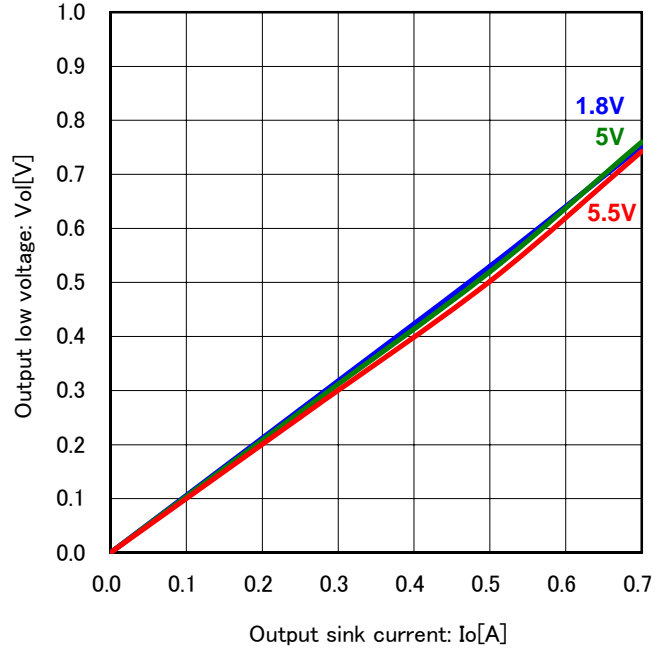

Fig.8 Output voltage (Ta=25°C)

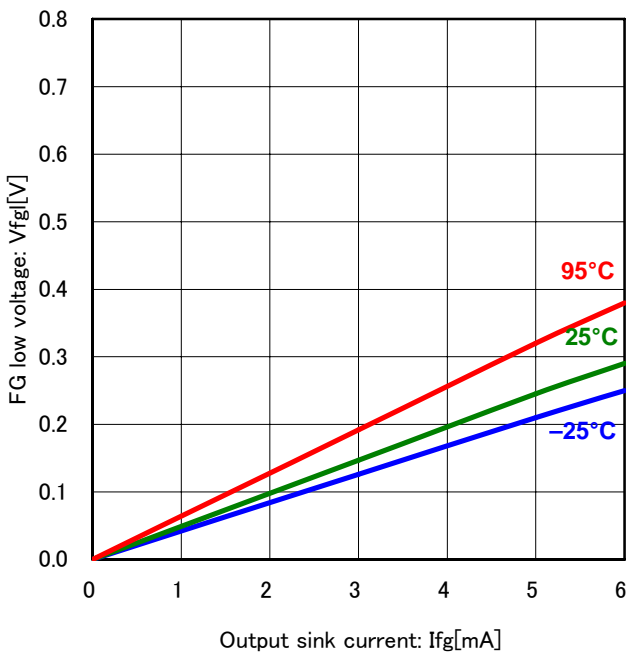

Fig.9 FG low voltage (Vcc=5V)

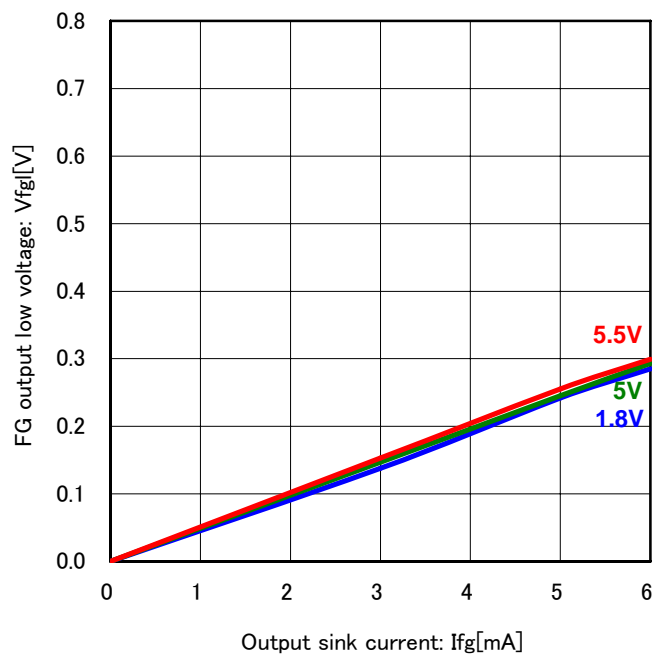

Fig.10 FG output low voltage (Ta=25°C)

●Typical performance curves(Reference data)

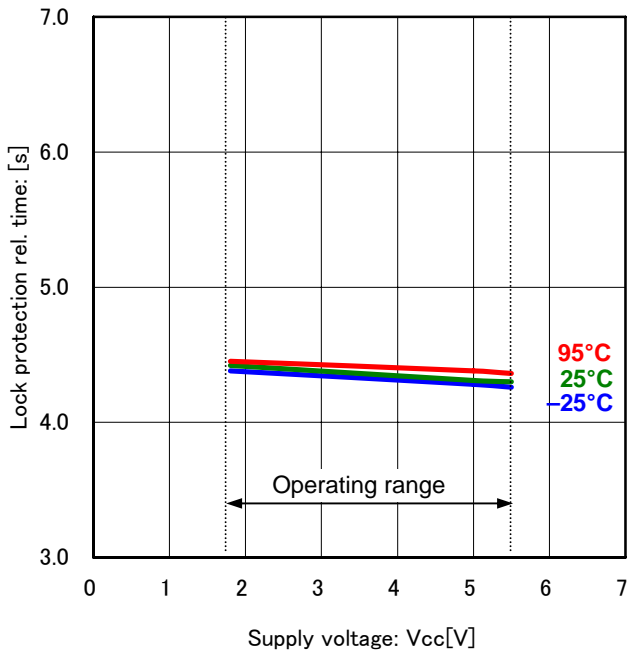

Fig.11 Lock protection rel. time

●Application circuit example(Constant values are for reference)

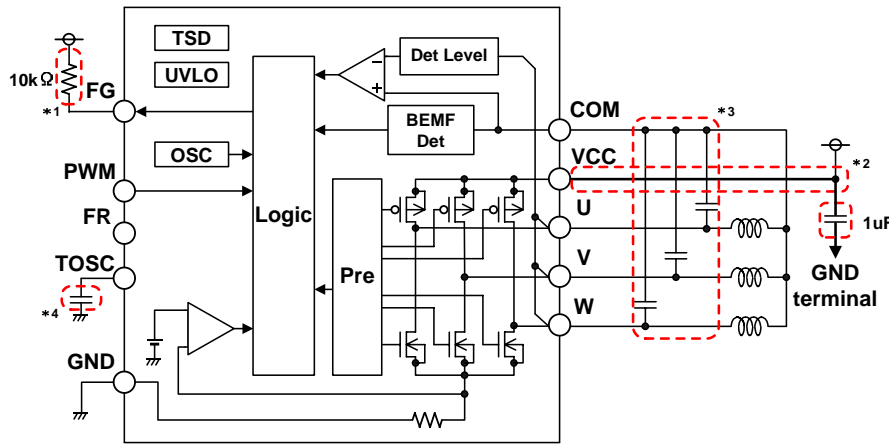

Fig.12 PWM controllable 4 wires type (FG) motor application circuit

- \*1 Open collector output. A pull-up resistances of 10kΩ should be inserted.
- \*2 The wiring patterns from the VCC terminal and GND terminal to the bypass capacitor must be routed as short as possible. With respect to the wiring pattern, It has been confirmed that 0.03Ω for 1μF at the bypass capacitor doesn't cause problems under our operation environment. This can be used as a reference value to check for validity.
- \*3 When it is noisy, Capacitance should be inserted between U, V, and W.
- \*4 Connect a capacitor between TOSC terminal and GND. Start-up frequency can be adjusted. Connect TOSC terminal to GND. Start-up synchronized time is fixed 200ms.

**Description of Function Operation**

1) Sensorless Drive

BH67172NUX is a motor driver IC for driving a three-phase brushless DC motor without a hall sensor. Detecting a rotor location firstly at startup, an appropriate logic for the rotation direction is obtained using this information and given to each phase to rotate the motor. Then, the rotation of the motor induces electromotive voltage in each phase wiring and the logic based on the induced electromotive voltage is applied to the each phase to continue rotating.

2) Motor output U, V, W and FG output signals

In Fig.13, the timing charts of the output signals from the U, V and W phases as well as the FG terminal is shown. Assuming that a three-slot tetrode motor is used, two pulse outputs of FG are produced for one motor cycle. The three phases are excited in the order of U, V and W phases.

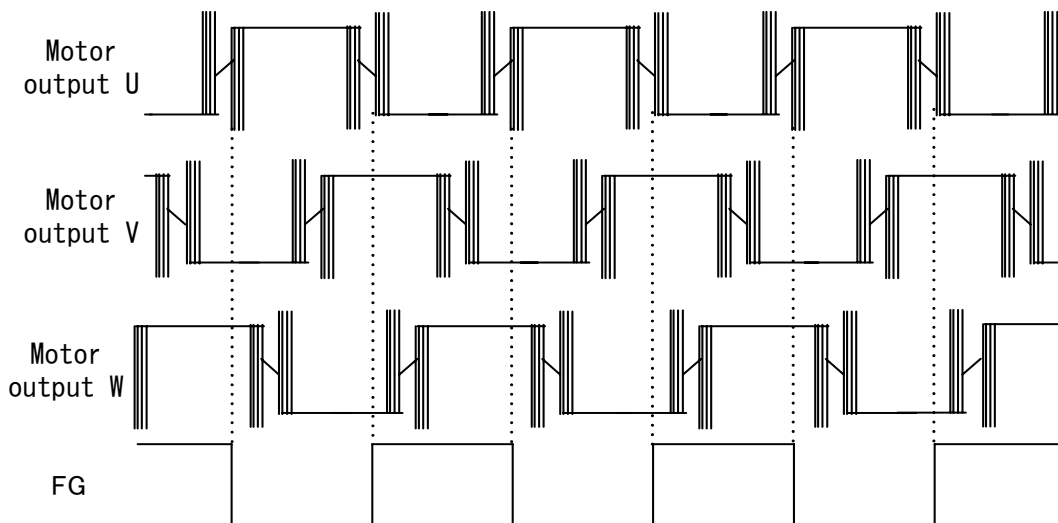

Fig.13 Motor Output , FG signal

Output pattern	Motor output		
	Motor output U	Motor output V	Motor output W
1	H	L	Hi-Z
2	H	Hi-Z	L
3	Hi-Z	H	L
4	L	H	Hi-Z
5	L	Hi-Z	H
3	Hi-Z	L	H

\* About the output pattern, It changes in the flow of "1→2→3 ~ 6→1".  
 H: High, L: Low, Hi-Z: High impedance

Table.1 truth table

3) Variable speed operation

About Rotational speed, It changes by PWM DUTY of the output of the lower side and upper side.

(Upper and lower PWM control drive method Fig.14)

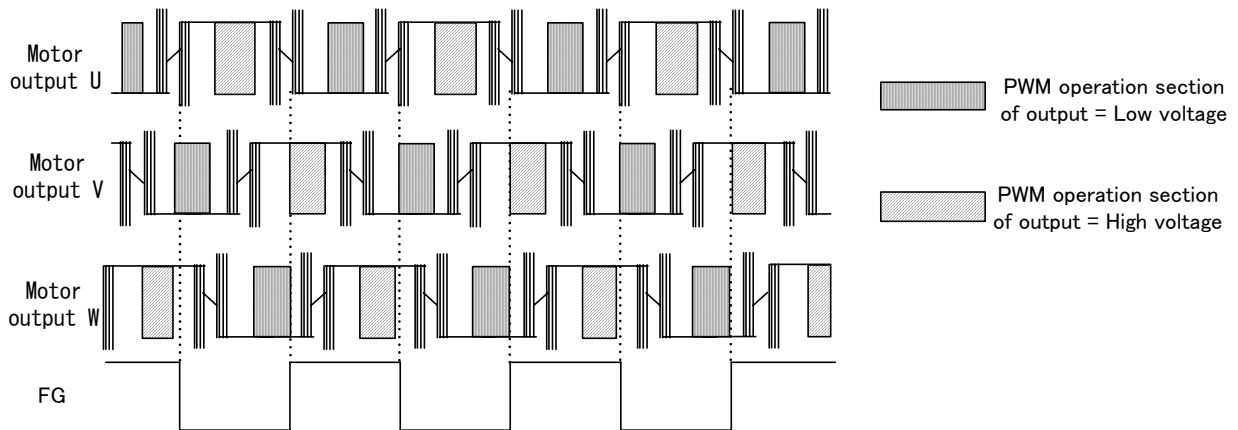

Fig.14 Motor output PWM drive explanation

4) Lock Protection Feature, Automatic Recovery Circuit

To prevent passing a coil current on any phase when a motor is locked, it is provided with a function which can turn OFF the output for a certain period of time and then automatically restore itself to the normal operation. During the motor rotation, an appropriate logic based on the induced electromotive voltage can be continuously given to each phase; on the other hand, when the motor is locked, no induced electromotive voltage is obtained. Utilizing this phenomenon to take a protective against locking, when the induced electromotive voltage is not detected for a predetermined period of time (TON), it is judged that the motor is locked and the output is turned OFF for a predetermined period of time (TOFF). In Fig.15, the timing chart is shown.

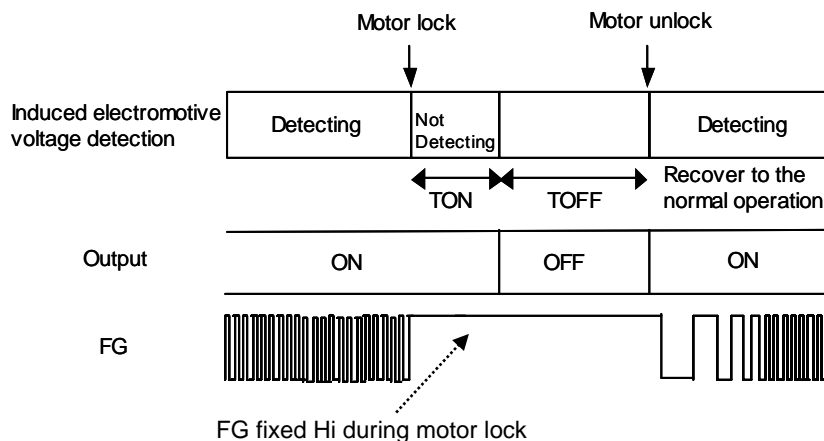

Fig.15 PWM signal and lock protection operation



## 5) Power saving function / Speed control by PWM input

The power saving function is controlled by an input logic of the PWM terminal.

- (a) Operate mode when the PWM terminal is High.
- (b) Standby mode when the PWM terminal is Low for a time period of 1ms (typ.).

When the PWM terminal is open, High logic is set.

Input logic of the PWM terminal is set at Low and then the Standby mode becomes effective 1ms (typ.) (Fig.16). In the Standby mode, the lock protection function is deactivated and the lock protection is not effective. Therefore, this device can start up instantly even from the stop state when the input logic of the PWM terminal is set at High.

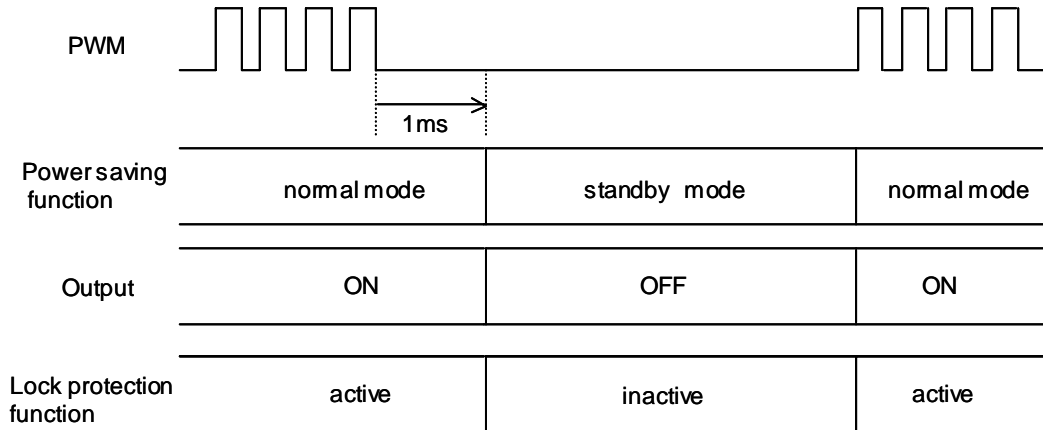

Fig.16 the power saving function

## 6) UVLO (Under voltage lock out circuit)

In the operation area under the guaranteed operating power supply voltage of 1.8V (typ.), the transistor on the output can be turned OFF at a power supply voltage of 1.58V (typ.). A hysteresis width of 100mV is provided and a normal operation can be performed at 1.68V. This function is installed to prevent unpredictable operations, such as a large amount of current passing through the output, by means of intentionally turning OFF the output during an operation at a very low power supply voltage which may cause an abnormal function in the internal circuit.

## 7) BEMF detection driving mechanism (synchronized start-up mechanism)

BH67172NUX's start mechanism is synchronized start-up mechanism. BH67172NUX as BEMF detection driving starts by set output logic and monitors BEMF voltage of motor. Driving mechanism changes to BEMF detection driving after detect BEMF signal. When BEMF signal isn't detected for constant time at start-up, synchronized start-up mechanism outputs output logic forcibly by using standard synchronized signal (sync signal) and makes motor forward drive. This assistance of motor start-up as constant cycle is synchronized driving mechanism. Synchronized frequency is standard synchronized signal. Fig.17 ,the timing chart (outline) is shown. " Motor start-up frequency setting " generation of synchronized period is shown.

## ✕Motor start-up frequency setting

The TOSC terminal starts a self-oscillation by connecting a capacitor between the TOSC terminal and GND. It becomes a start-up frequency, and synchronized time. Synchronized time can be adjusted by changing external capacitor. When the capacitor value is small, synchronized time becomes short. It is necessary to choose the best capacitor value for optimum start-up operation. For example external capacitor is 2200pF, synchronized time is 200ms(typ.). 2200pF is recommended for setting value at first. Relationship between external capacitor and synchronized time is shown in below. When connect TOSC terminal to GND, synchronized time is fixed and synchronized time is same as 2200pF.

## ✕Setting of Appropriate capacitor value

Appropriate value of synchronized time is differ with characteristic and parameter of motor. Appropriate value decided by start-up confirmation with various capacitor value. At first confirm start-up with 2200pF,next is 2400,2700,3000,3300pF···,and 2000,1800,1600,1500,1300pF···etc. Appropriate capacitor value is decided after confirm maximum start-up NG value and minimum start-up NG value. For example, small BEMF voltage motor tends to small capacitor value. Set capacitor value after confirm sufficiently.

Attention : We provide with automatic start-up confirmation tool. We will supply this tool when you request.

< Diagram of Relationship between TOSC terminal and synchronized time >

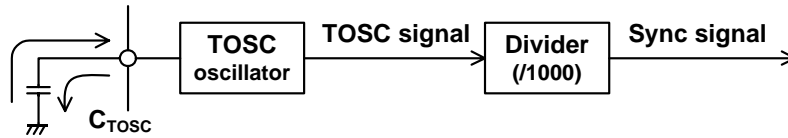

Synchronized time = 8000 x TOSC period  
 Charge current : 100uA discharge current : 100uA

Ex.  $C_{TOSC} = 2200\text{pF}$   
 TOSC frequency = 40kHz(typ).  
 TOSC period = 25usec.  
 Synchronized time = 200msec.

Equation

$$T_{OSC} = 2x \frac{C_{TOSC} V_{TOSC}}{I}$$

$C_{TOSC}$  : Tosc terminal capacitor value  
 $V_{TOSC}$  : Tosc terminal Hi voltage – Lo voltage= 0.57V (typ.)  
 $I$  : Tosc terminal charge and discharge current

External capacitor	Synchronized time
3300pF	300ms
2200pF	200ms
1000pF	90ms
670pF	60ms

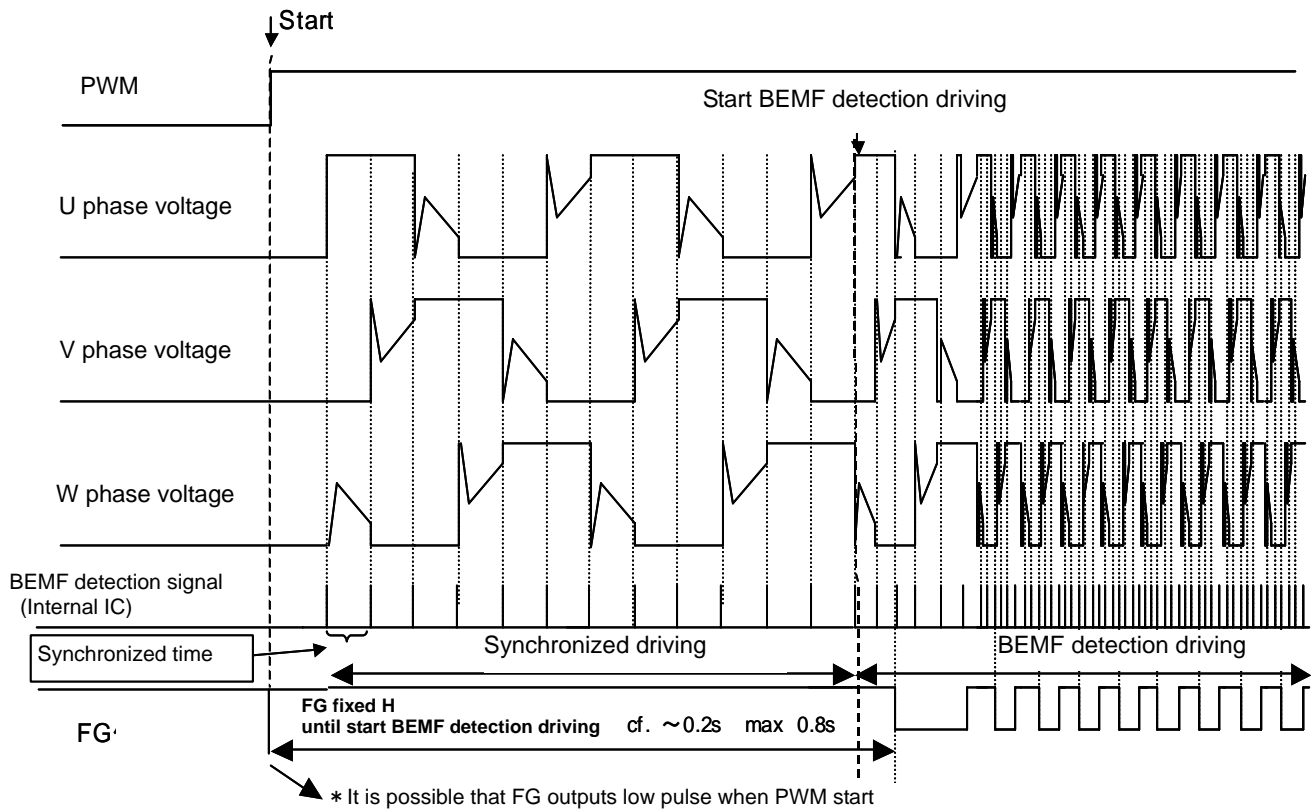

Fig.17 Timing chart

\* Setting of electrify angle and output duty while start-up

	Number of BEMF detection (from start-up)		
	Start-up	Until BEMF detection 6 times successively	after BEMF detection 6 times successively
Synchronized time	8000 x TOSC		
PWM duty	PWM = fixed 100%		PWM = same as external PWM duty
Electrify angle	120°		150°

\*Disagree with above timing chart

● Thermal derating curve

Permissible dissipation (total loss) indicates the power that can be consumed by IC at Ta = 25°C (normal temperature). IC is heated when it consumes power, and the temperature of IC chip becomes higher than ambient temperature. The temperature that can be accepted by IC chip depends on circuit configuration, manufacturing process, etc, and consumable power is limited. Permissible dissipation is determined by the temperature allowed in IC chip (maximum junction temperature) and thermal resistance of package (heat dissipation capability). The maximum junction temperature is in general equal to the maximum value in the storage temperature range.

Heat generated by consumed power of IC is radiated from the mold resin or lead frame of package. The parameter which indicates this heat dissipation capability (hardness of heat release) is called heat resistance, represented by the symbol θja [C/W]. The temperature of IC inside the package can be estimated by this heat resistance. Below Figure shows the model of heat resistance of the package.

Heat resistance θja, ambient temperature Ta, junction temperature Tj, and power consumption P can be calculated by the equation below:

$$\theta_{ja} = (T_j - T_a) / P \quad [^{\circ}\text{C}/\text{W}]$$

Thermal derating curve indicates power that can be consumed by IC with reference to ambient temperature. Power that can be consumed by IC begins to attenuate at certain ambient temperature. This gradient is determined by thermal resistance θja.

Thermal resistance θja depends on chip size, power consumption, package ambient temperature, packaging condition, wind velocity, etc even when the same package is used. Thermal derating curve indicates a reference value measured at a specified condition. Below Figure shows a thermal derating curve. (Value when mounting FR4 glass epoxy board 74.2 [mm] x 74.2 [mm] x 1.6 [mm] (copper foil area below 3 [%]))

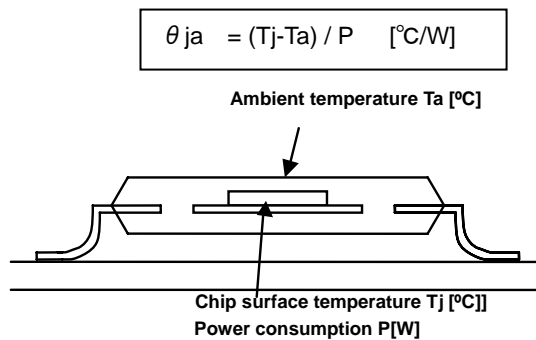
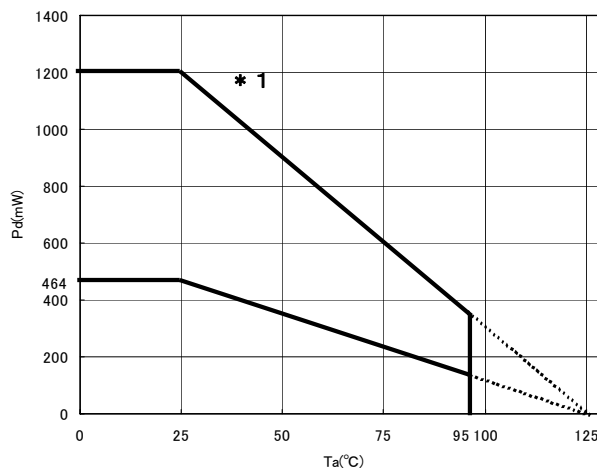

Fig.18 Thermal resistance



- \* Above Ta = 25°C, derating by 4.64 mW/°C  
(When glass epoxy board (single layer) of 74.2 mm x 74.2 mm x 1.6 mm is mounted)
- \* 1 Above Ta=25°C, derating by 12 mW/°C  
(When glass epoxy board (double layer) of 20.0mmx20.0mmX1.2mm is mounted. Top layer area 65mm<sup>2</sup>, Bottom area 8mm<sup>2</sup>)

Fig.19 Thermal derating curve

●Equivalent circuit

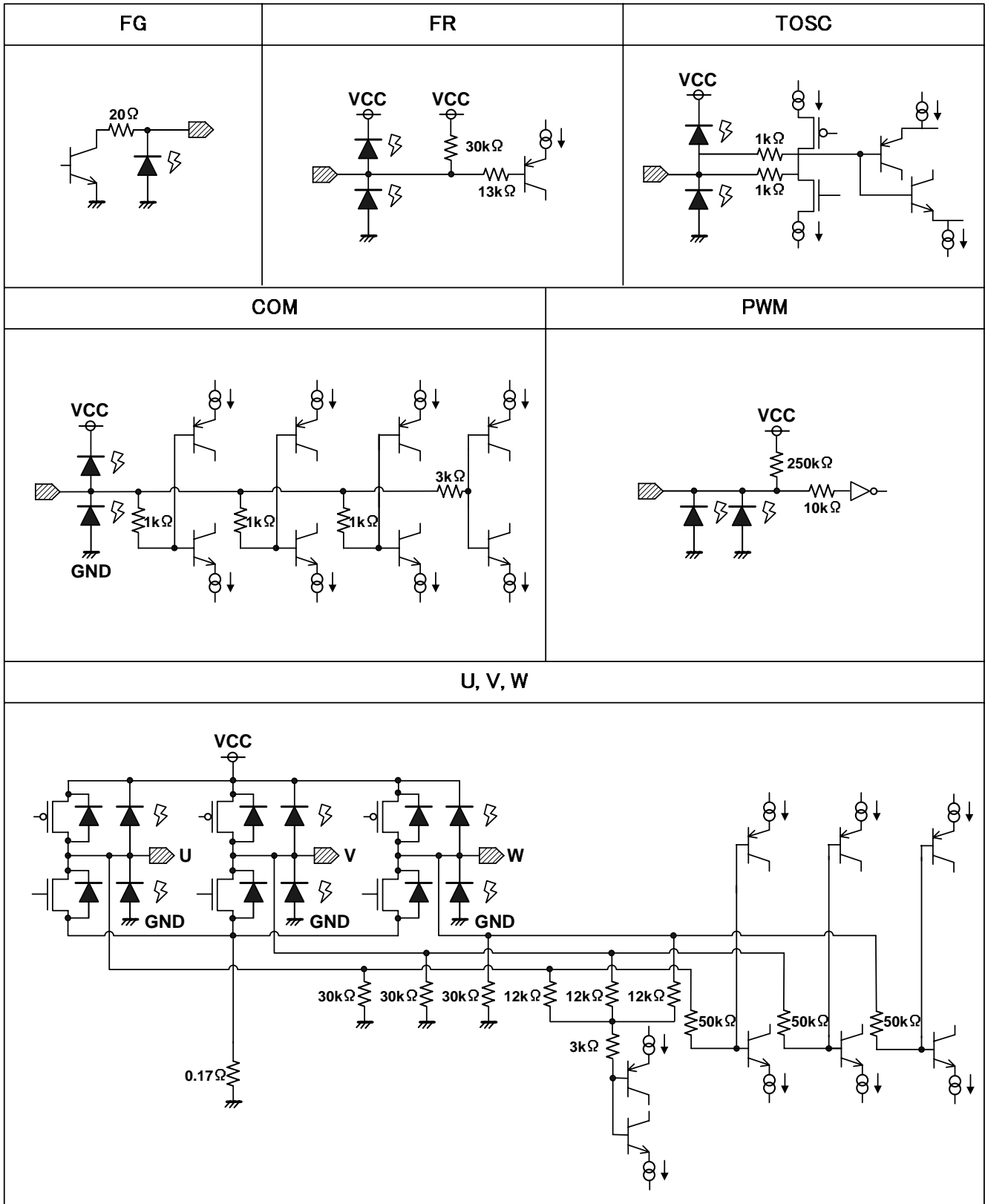

● Safety measure

1) Reverse connection protection diode

Reverse connection of power results in IC destruction as shown in Fig.20. When reverse connection is possible, reverse connection destruction preventive diode must be added between power supply and Vcc.

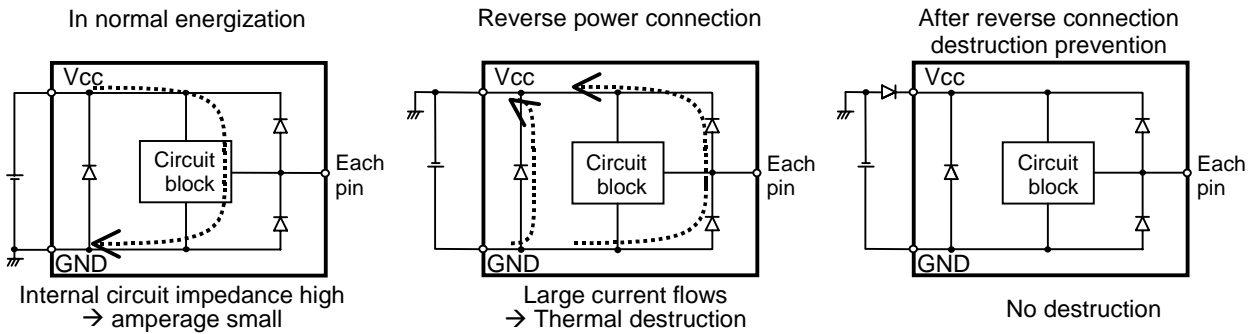

Fig.20 Flow of current when power is connected reversely

2) Measure against Vcc voltage rise by back electromotive force

Back electromotive force (Back EMF) generates regenerative current to power supply. However, when reverse connection protection diode is connected, Vcc voltage rises because no route is available for regenerating to power.

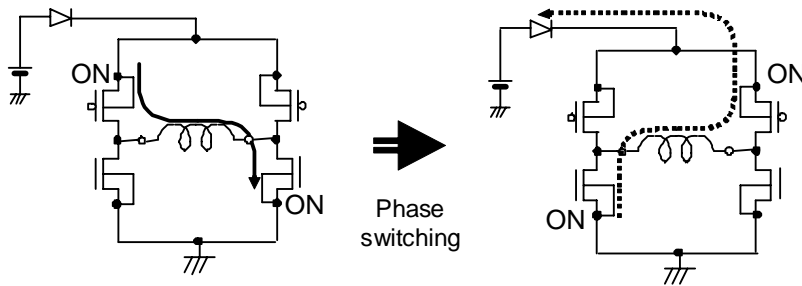

Fig.21 Vcc voltage rise by back electromotive force

When the absolute maximum rated voltage may be exceeded due to voltage rise by back electromotive force, place (A) Capacitor or (B) Zener diode between Vcc and GND. In addition, also take the measure (A) and (B) as shown in (C) if required.

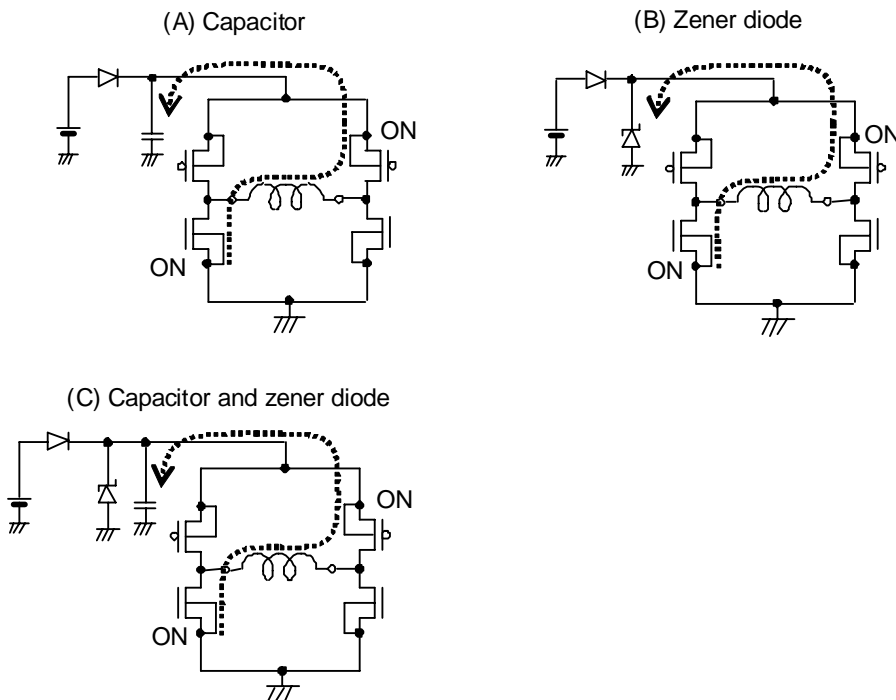

Fig.22 Measure against Vcc voltage rise

3) Problem of GND line PWM switching

Do not perform PWM switching of GND line because the potential of GND terminal cannot be kept at the minimum.

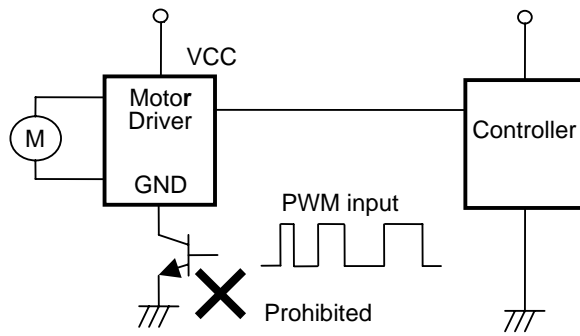

Fig.23 GND Line PWM switching prohibited

4) FG output

FG output is an open drain and requires pull-up resistor.

The IC can be protected by adding resistor R1. An excess of absolute maximum rating, when FG output terminal is directly connected to power supply, could damage the IC.

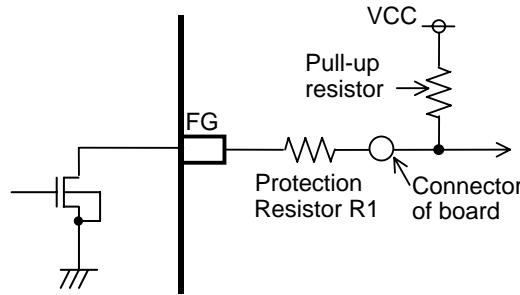

Fig.24 Protection of FG terminal

**●Operational Notes**

- 1) Absolute maximum ratings  
An excess in the absolute maximum ratings, such as supply voltage, temperature range of operating conditions, etc., can break down the devices, thus making impossible to identify breaking mode, such as a short circuit or an open circuit. If any over rated values will expect to exceed the absolute maximum ratings, consider adding circuit protection devices, such as fuses.
- 2) Connecting the power supply connector backward  
Connecting of the power supply in reverse polarity can damage IC. Take precautions when connecting the power supply lines. An external direction diode can be added.
- 3) Power supply line  
Back electromotive force causes regenerated current to power supply line, therefore take a measure such as placing a capacitor between power supply and GND for routing regenerated current. And fully ensure that the capacitor characteristics have no problem before determine a capacitor value. (when applying electrolytic capacitors, capacitance characteristic values are reduced at low temperatures)
- 4) GND potential  
The potential of GND pin must be minimum potential in all operating conditions. Also ensure that all terminals except GND terminal do not fall below GND voltage including transient characteristics. However, it is possible that the motor output terminal may deflect below GND because of influence by back electromotive force of motor. Malfunction may possibly occur depending on use condition, environment, and property of individual motor. Please make fully confirmation that no problem is found on operation of IC.
- 5) Thermal design  
Use a thermal design that allows for a sufficient margin in light of the power dissipation (Pd) in actual operating conditions.
- 6) Inter-pin shorts and mounting errors  
Use caution when positioning the IC for mounting on printed circuit boards. The IC may be damaged if there is any connection error or if pins are shorted together.
- 7) Actions in strong electromagnetic field  
Use caution when using the IC in the presence of a strong electromagnetic field as doing so may cause the IC to malfunction.
- 8) ASO  
When using the IC, set the output transistor so that it does not exceed absolute maximum ratings or ASO.
- 9) Thermal shut down circuit  
The IC incorporates a built-in thermal shutdown circuit (TSD circuit). Operation temperature is 150°C(Typ.) and has a hysteresis width of 15°C(Typ.). When IC chip temperature rises and TSD circuit works, the output terminal becomes an open state. TSD circuit is designed only to shut the IC off to prevent thermal runaway. It is not designed to protect the IC or guarantee its operation. Do not continue to use the IC after operation this circuit or use the IC in an environment where the operation of this circuit is assumed.
- 10) Testing on application boards  
When testing the IC on an application board, connecting a capacitor to a pin with low impedance subjects the IC to stress. Always discharge capacitors after each process or step. Always turn the IC's power supply off before connecting it to or removing it from a jig or fixture during the inspection process. Ground the IC during assembly steps as an antistatic measure. Use similar precaution when transporting or storing the IC.
- 11) GND wiring pattern  
When using both small signal and large current GND patterns, it is recommended to isolate the two ground patterns, placing a single ground point at the ground potential of application so that the pattern wiring resistance and voltage variations caused by large currents do not cause variations in the small signal ground voltage. Be careful not to change the GND wiring pattern of any external components, either.
- 12) IC terminal input  
When VCC voltage is not applied to IC, do not apply voltage to each input terminal. When voltage above VCC or below GND is applied to the input terminal, parasitic element is actuated due to the structure of IC. Operation of parasitic element causes mutual interference between circuits, resulting in malfunction as well as destruction in the last. Do not use in a manner where parasitic element is actuated.
- 13) FR function  
Switching H/L of FR terminal should not be done during the motor rotation. it should be done from once the motor stop. FR terminal should be connected to VCC or GND for reducing PWM noise.

**●Status of this document**

The Japanese version of this document is formal specification. A customer may use this translation version only for a reference to help reading the formal version.

If there are any differences in translation version of this document formal version takes priority

●Ordering Information

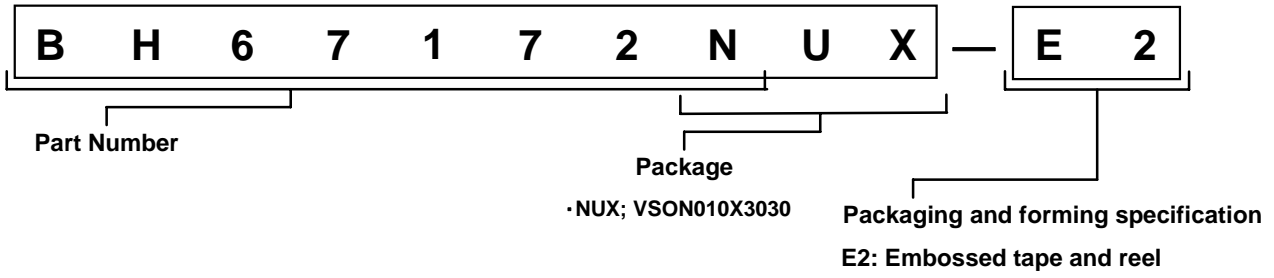

●Physical dimension tape and reel information

VSON010X3030

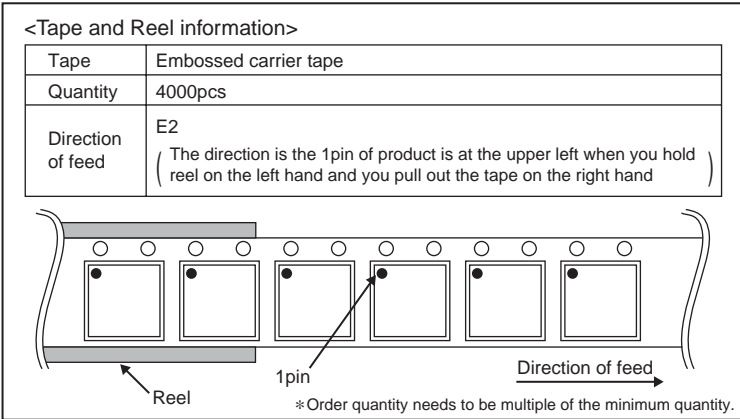
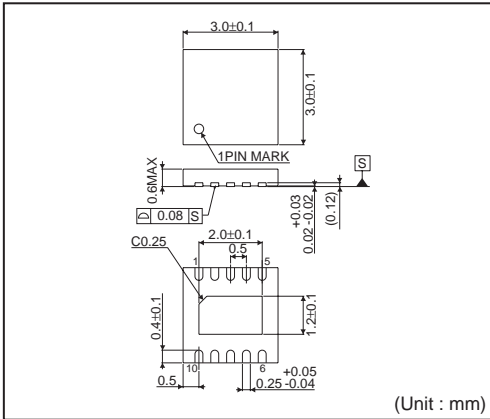

●Marking diagram

VSON010X3030 (TOP VIEW)

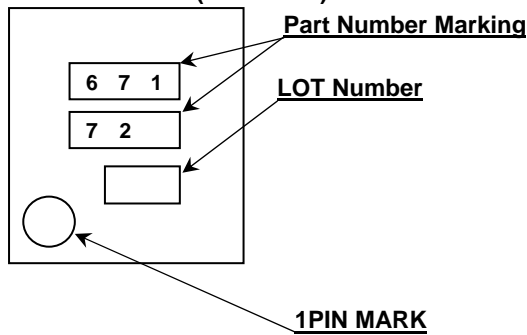



# Notice

## ●General Precaution

- 1) Before you use our Products, you are requested to carefully read this document and fully understand its contents. ROHM shall not be in any way responsible or liable for failure, malfunction or accident arising from the use of any ROHM's Products against warning, caution or note contained in this document.
- 2) All information contained in this document is current as of the issuing date and subject to change without any prior notice. Before purchasing or using ROHM's Products, please confirm the latest information with a ROHM sales representative.

## ●Precaution on using ROHM Products

- 1) Our Products are designed and manufactured for application in ordinary electronic equipments (such as AV equipment, OA equipment, telecommunication equipment, home electronic appliances, amusement equipment, etc.). If you intend to use our Products in devices requiring extremely high reliability (such as medical equipment, transport equipment, traffic equipment, aircraft/spacecraft, nuclear power controllers, fuel controllers, car equipment including car accessories, safety devices, etc.) and whose malfunction or failure may cause loss of human life, bodily injury or serious damage to property ("Specific Applications"), please consult with the ROHM sales representative in advance. Unless otherwise agreed in writing by ROHM in advance, ROHM shall not be in any way responsible or liable for any damages, expenses or losses incurred by you or third parties arising from the use of any ROHM's Products for Specific Applications.
- 2) ROHM designs and manufactures its Products subject to strict quality control system. However, semiconductor products can fail or malfunction at a certain rate. Please be sure to implement, at your own responsibilities, adequate safety measures including but not limited to fail-safe design against the physical injury, damage to any property, which a failure or malfunction of our Products may cause. The following are examples of safety measures:
  - [a] Installation of protection circuits or other protective devices to improve system safety
  - [b] Installation of redundant circuits to reduce the impact of single or multiple circuit failure
- 3) Our Products are designed and manufactured for use under standard conditions and not under any special or extraordinary environments or conditions, as exemplified below. Accordingly, ROHM shall not be in any way responsible or liable for any damages, expenses or losses arising from the use of any ROHM's Products under any special or extraordinary environments or conditions. If you intend to use our Products under any special or extraordinary environments or conditions (as exemplified below), your independent verification and confirmation of product performance, reliability, etc. prior to use, must be necessary:
  - [a] Use of our Products in any types of liquid, including water, oils, chemicals, and organic solvents
  - [b] Use of our Products outdoors or in places where the Products are exposed to direct sunlight or dust
  - [c] Use of our Products in places where the Products are exposed to sea wind or corrosive gases, including Cl<sub>2</sub>, H<sub>2</sub>S, NH<sub>3</sub>, SO<sub>2</sub>, and NO<sub>2</sub>
  - [d] Use of our Products in places where the Products are exposed to static electricity or electromagnetic waves
  - [e] Use of our Products in proximity to heat-producing components, plastic cords, or other flammable items
  - [f] Sealing or coating our Products with resin or other coating materials
  - [g] Use of our Products without cleaning residue of flux (even if you use no-clean type fluxes, cleaning residue of flux is recommended); or Washing our Products by using water or water-soluble cleaning agents for cleaning residue after soldering
  - [h] Use of the Products in places subject to dew condensation
- 4) The Products are not subject to radiation-proof design.
- 5) Please verify and confirm characteristics of the final or mounted products in using the Products.
- 6) In particular, if a transient load (a large amount of load applied in a short period of time, such as pulse) is applied, confirmation of performance characteristics after on-board mounting is strongly recommended. Avoid applying power exceeding normal rated power; exceeding the power rating under steady-state loading condition may negatively affect product performance and reliability.
- 7) De-rate Power Dissipation (Pd) depending on Ambient temperature (Ta). When used in sealed area, confirm the actual ambient temperature.
- 8) Confirm that operation temperature is within the specified range described in the product specification.
- 9) ROHM shall not be in any way responsible or liable for failure induced under deviant condition from what is defined in this document.

**●Precaution for Mounting / Circuit board design**

- 1) When a highly active halogenous (chlorine, bromine, etc.) flux is used, the residue of flux may negatively affect product performance and reliability.
- 2) In principle, the reflow soldering method must be used; if flow soldering method is preferred, please consult with the ROHM representative in advance.

For details, please refer to ROHM Mounting specification

**●Precautions Regarding Application Examples and External Circuits**

- 1) If change is made to the constant of an external circuit, please allow a sufficient margin considering variations of the characteristics of the Products and external components, including transient characteristics, as well as static characteristics.
- 2) You agree that application notes, reference designs, and associated data and information contained in this document are presented only as guidance for Products use. Therefore, in case you use such information, you are solely responsible for it and you must exercise your own independent verification and judgment in the use of such information contained in this document. ROHM shall not be in any way responsible or liable for any damages, expenses or losses incurred by you or third parties arising from the use of such information.

**●Precaution for Electrostatic**

This Product is electrostatic sensitive product, which may be damaged due to electrostatic discharge. Please take proper caution in your manufacturing process and storage so that voltage exceeding the Products maximum rating will not be applied to Products. Please take special care under dry condition (e.g. Grounding of human body / equipment / solder iron, isolation from charged objects, setting of Ionizer, friction prevention and temperature / humidity control).

**●Precaution for Storage / Transportation**

- 1) Product performance and soldered connections may deteriorate if the Products are stored in the places where:
  - [a] the Products are exposed to sea winds or corrosive gases, including Cl<sub>2</sub>, H<sub>2</sub>S, NH<sub>3</sub>, SO<sub>2</sub>, and NO<sub>2</sub>
  - [b] the temperature or humidity exceeds those recommended by ROHM
  - [c] the Products are exposed to direct sunshine or condensation
  - [d] the Products are exposed to high Electrostatic
- 2) Even under ROHM recommended storage condition, solderability of products out of recommended storage time period may be degraded. It is strongly recommended to confirm solderability before using Products of which storage time is exceeding the recommended storage time period.
- 3) Store / transport cartons in the correct direction, which is indicated on a carton with a symbol. Otherwise bent leads may occur due to excessive stress applied when dropping of a carton.
- 4) Use Products within the specified time after opening a humidity barrier bag. Baking is required before using Products of which storage time is exceeding the recommended storage time period.

**●Precaution for Product Label**

QR code printed on ROHM Products label is for ROHM's internal use only.

**●Precaution for Disposition**

When disposing Products please dispose them properly using an authorized industry waste company.

**●Precaution for Foreign Exchange and Foreign Trade act**

Since our Products might fall under controlled goods prescribed by the applicable foreign exchange and foreign trade act, please consult with ROHM representative in case of export.

**●Precaution Regarding Intellectual Property Rights**

- 1) All information and data including but not limited to application example contained in this document is for reference only. ROHM does not warrant that foregoing information or data will not infringe any intellectual property rights or any other rights of any third party regarding such information or data. ROHM shall not be in any way responsible or liable for infringement of any intellectual property rights or other damages arising from use of such information or data.:
- 2) No license, expressly or implied, is granted hereby under any intellectual property rights or other rights of ROHM or any third parties with respect to the information contained in this document.

●Other Precaution

- 1) The information contained in this document is provided on an "as is" basis and ROHM does not warrant that all information contained in this document is accurate and/or error-free. ROHM shall not be in any way responsible or liable for any damages, expenses or losses incurred by you or third parties resulting from inaccuracy or errors of or concerning such information.
- 2) This document may not be reprinted or reproduced, in whole or in part, without prior written consent of ROHM.
- 3) The Products may not be disassembled, converted, modified, reproduced or otherwise changed without prior written consent of ROHM.
- 4) In no event shall you use in any way whatsoever the Products and the related technical information contained in the Products or this document for any military purposes, including but not limited to, the development of mass-destruction weapons.
- 5) The proper names of companies or products described in this document are trademarks or registered trademarks of ROHM, its affiliated companies or third parties.