

- ◆ Structure Silicon monolithic integrated circuit
- ◆ Product Single Channel 16-bit CIS/CCD Analog Front End
- ◆ Type **BU6574FV**
- ◆ Features
 - Correlated double sampling (CDS)
 - Programmable gain amplifier (8bit resolution)
 - 16bit 6MSPS ADC
 - Serial control interface
 - Offset calibration DAC (8bit resolution)
 - Internally generated voltage references
 - 4bit wide multiplexed data output format

◆ Absolute maximum ratings (Ta=25°C)

Parameter	Symbol	Ratings	Unit
Supply voltage 1	V _{AVDD}	-0.2 to 4.0	V
Supply voltage 2	V _{DVDD}	-0.2 to 4.0	V
I/O supply voltage	V _{VDDIO}	-0.2 to 4.0	V
Digital input voltage *1	V _{ID}	-0.2 to V _{VDDIO} + 0.3	V
Digital output voltage *2	V _{OD}	-0.2 to V _{VDDIO} + 0.3	V
Analog input voltage *3	V _{IA}	-0.2 to V _{AVDD} + 0.3	V
Analog output voltage *4	V _{OA}	-0.2 to V _{AVDD} + 0.3	V
Storage temperature	T _{stg}	-25 to 125	°C
Power dissipation *5	P _d	400	mW

*1 : Pin No.3,4,6,8,9 *2 : Pin No.10,11,12,13 *3 : Pin No.20 *4 : Pin No.16,17,18,19
 *5 : Reduced by 4mW for each increase in Ta of 1°C over 25°C

◆ Operating conditions (Ta = 0°C to 70°C)

Parameter	Symbol	MIN	TYP	MAX	Unit
Supply voltage 1	V _{AVDD}	3.135	3.3	3.465	V
Supply voltage 2	V _{DVDD}	3.135	3.3	3.465	V
I/O supply voltage	V _{VDDIO}	3.0	3.3	3.6	V

This product is not designed for protection against radioactive rays

Status of this document

The Japanese version of this document is the formal specification.

A customer may use this translation version only for a reference to help reading the formal version.

If there are any differences in translation version of this document, formal version takes priority.

◆Electrical characteristics (Unless otherwise noted, VAVDD=VDVDD=VVDDIO = 3.3V, Ta = 25°C)

Parameter	Symbol	MIN	TYP	MAX	Unit	Conditions
Overall System Specification						
Input signal limits	V _{IN}	0.26	–	2.7	V	
Conversion Rate	RATE	–	–	6	MSPS	
Digital Inputs						
High level input voltage	V _{IH}	0.7*V _{VDDIO}	–	–	V	
Low level input voltage	V _{IL}	–	–	0.2*V _{VDDIO}	V	
High level input current	I _{IH}	–	–	1	uA	
Low level input current	I _{IL}	–	–	1	uA	
Digital Outputs						
High level output voltage	V _{OH}	V _{VDDIO} –0.5	–	–	V	I _{OH} = 1mA
Low level output voltage	V _{OL}	–	–	0.5	V	I _{OL} = 1mA
Supply Currents						
Total supply current - active	I _{TOTAL}	–	35.7 41.7	70	mA	MCLK = 12MHz MCLK = 24MHz
Total Analog AVDD, Supply current - active	I _{AVDD}	–	32 34	50	mA	MCLK = 12MHz MCLK = 24MHz
Total digital DVDD, Supply current - active	I _{DVDD}	–	1.5 3.0	10	mA	MCLK = 12MHz MCLK = 24MHz
Total digital I/O, Supply current - active	I _{VDDIO}	–	2.2 4.4	10	mA	MCLK = 12MHz MCLK = 24MHz
Supply current – full power down mode	I _{PD}	–	30	60	uA	MCLK=Low

◆ Package outline

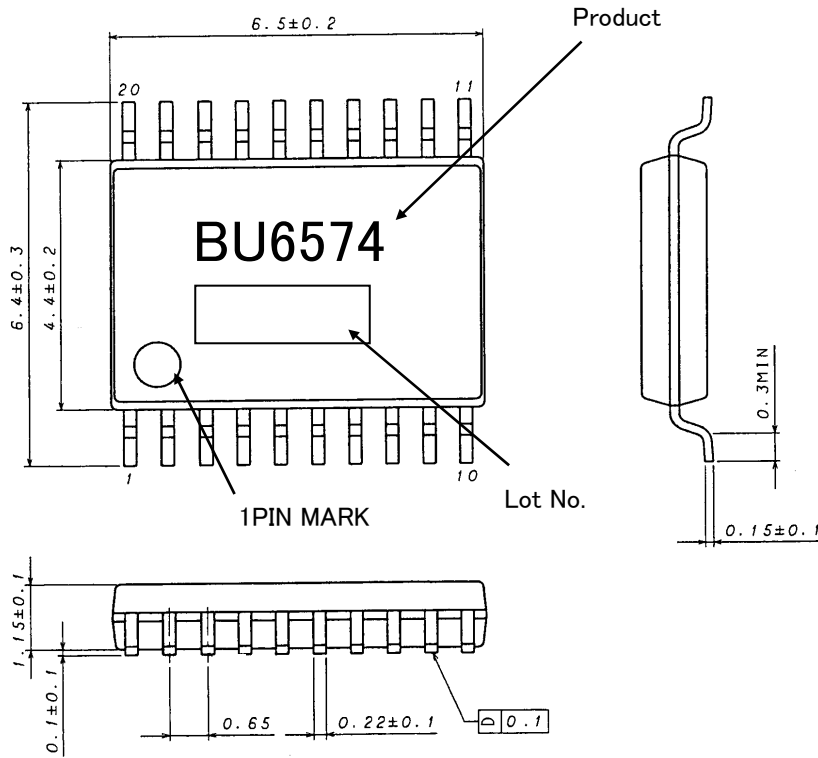

SSOP-B20 (Unit:mm)

◆ Block diagram

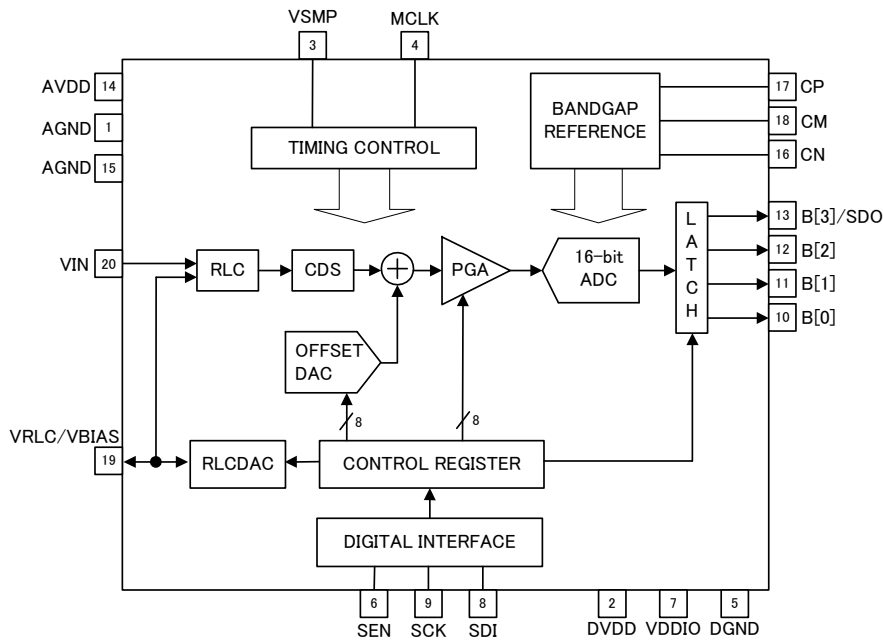

◆ Pin description

Pin Number	Pin Name
1	AGND
2	DVDD
3	VSMP
4	MCLK
5	DGND
6	SEN
7	VDDIO
8	SDI
9	SCK
10	B[0]
11	B[1]
12	B[2]
13	B[3]/SDO
14	AVDD
15	AGND
16	CN
17	CP
18	CM
19	VRLC/VBIAS
20	VIN

●Cautions on use

(1) Absolute Maximum Ratings

An excess in the absolute maximum ratings, such as supply voltage, temperature range of operating conditions, etc., can break down devices, thus making impossible to identify breaking mode such as a short circuit or an open circuit. If any special mode exceeding the absolute maximum ratings is assumed, consideration should be given to take physical safety measures including the use of fuses, etc.

(2) Power supply and GND line

Design PCB pattern to provide low impedance for the wiring between the power supply and the GND lines. Pay attention to the interference by common impedance of layout pattern when there are plural power supplies and GND lines. Especially, when there are GND pattern for small signal and GND pattern for large current included the external circuits, separate each GND pattern. Furthermore, for all power supply terminals to ICs, mount a capacitor between the power supply and the GND terminal. At the same time, in order to use a capacitor, thoroughly check to be sure the characteristics of the capacitor to be used present no problem including the occurrence of capacity dropout at a low temperature, thus determining the constant.

(3) GND voltage

Make setting of the potential of the GND terminal so that it will be maintained at the minimum in any operating state. Furthermore, check to be sure no terminals are at a potential lower than the GND voltage including an actual electric transient.

(4) Short circuit between terminals and erroneous mounting

In order to mount ICs on a set PCB, pay thorough attention to the direction and offset of the ICs. Erroneous mounting can break down the ICs. Furthermore, if a short circuit occurs due to foreign matters entering between terminals or between the terminal and the power supply or the GND terminal, the ICs can break down.

(5) Operation in strong electromagnetic field

Be noted that using ICs in the strong electromagnetic field can malfunction them.

(6) Input terminals

In terms of the construction of IC, parasitic elements are inevitably formed in relation to potential. The operation of the parasitic element can cause interference with circuit operation, thus resulting in a malfunction and then breakdown of the input terminal. Therefore, pay thorough attention not to handle the input terminals, such as to apply to the input terminals a voltage lower than the GND respectively, so that any parasitic element will operate. Furthermore, do not apply a voltage to the input terminals when no power supply voltage is applied to the IC. In addition, even if the power supply voltage is applied, apply to the input terminals a voltage lower than the power supply voltage or within the guaranteed value of electrical characteristics.

(7) External capacitor

In order to use a ceramic capacitor as the external capacitor, determine the constant with consideration given to a degradation in the nominal capacitance due to DC bias and changes in the capacitance due to temperature, etc.

Notes

No copying or reproduction of this document, in part or in whole, is permitted without the consent of ROHM Co.,Ltd.

The content specified herein is subject to change for improvement without notice.

The content specified herein is for the purpose of introducing ROHM's products (hereinafter "Products"). If you wish to use any such Product, please be sure to refer to the specifications, which can be obtained from ROHM upon request.

Examples of application circuits, circuit constants and any other information contained herein illustrate the standard usage and operations of the Products. The peripheral conditions must be taken into account when designing circuits for mass production.

Great care was taken in ensuring the accuracy of the information specified in this document. However, should you incur any damage arising from any inaccuracy or misprint of such information, ROHM shall bear no responsibility for such damage.

The technical information specified herein is intended only to show the typical functions of and examples of application circuits for the Products. ROHM does not grant you, explicitly or implicitly, any license to use or exercise intellectual property or other rights held by ROHM and other parties. ROHM shall bear no responsibility whatsoever for any dispute arising from the use of such technical information.

The Products specified in this document are intended to be used with general-use electronic equipment or devices (such as audio visual equipment, office-automation equipment, communication devices, electronic appliances and amusement devices).

The Products specified in this document are not designed to be radiation tolerant.

While ROHM always makes efforts to enhance the quality and reliability of its Products, a Product may fail or malfunction for a variety of reasons.

Please be sure to implement in your equipment using the Products safety measures to guard against the possibility of physical injury, fire or any other damage caused in the event of the failure of any Product, such as derating, redundancy, fire control and fail-safe designs. ROHM shall bear no responsibility whatsoever for your use of any Product outside of the prescribed scope or not in accordance with the instruction manual.

The Products are not designed or manufactured to be used with any equipment, device or system which requires an extremely high level of reliability the failure or malfunction of which may result in a direct threat to human life or create a risk of human injury (such as a medical instrument, transportation equipment, aerospace machinery, nuclear-reactor controller, fuel-controller or other safety device). ROHM shall bear no responsibility in any way for use of any of the Products for the above special purposes. If a Product is intended to be used for any such special purpose, please contact a ROHM sales representative before purchasing.

If you intend to export or ship overseas any Product or technology specified herein that may be controlled under the Foreign Exchange and the Foreign Trade Law, you will be required to obtain a license or permit under the Law.



Thank you for your accessing to ROHM product informations.
More detail product informations and catalogs are available, please contact us.

ROHM Customer Support System

<http://www.rohm.com/contact/>