

STRUCTURE	Silicon Monolithic Integrated Circuit
PRODUCT SERIES	FM stereo transmitter IC for the car audio system.
TYPE	<b>BH1414K</b>
FEATURES	<ul style="list-style-type: none"> <li>• It is possible to set a level by the difference of the input source with the serial data because it has an EVR.</li> <li>• It is possible to attempt to improve a timbre because it has the limiter circuit and trap filter circuit of 19kHz and 38kHz.</li> <li>• Built-in the pilot-tone system FM stereo modulator circuit.</li> <li>• It becomes a monaural mode with the serial data.</li> <li>• Built-in the sound muting circuit.</li> <li>• The transmission frequency is stable because it has PLL system FM transmitter circuit.</li> <li>• PLL data input (CE, CK, DA) by serial input.</li> </ul>

○ Absolute Maximum Ratings (Ta=25°C)

Parameter	Symbol	Limits	Unit	Conditions
Supply voltage 1	Vcc1	+9.0	V	Pin 17
Supply voltage 2	Vcc2	+9.0	V	Pin 36
Supply voltage 3	Vcc3	+9.0	V	Pin 25
Port output terminal voltage	V <sub>P29</sub>	+10.0	V	Pin 29
Data input voltage	V <sub>IN-D</sub>	-0.3 ~ Vcc2+0.3	V	Pin 30, 31, 32, 33
Phase comparator output voltage	V <sub>OUT-P</sub>	-0.3 ~ Vcc2+0.3	V	Pin 20
Power dissipation	Pd	500	mW	(*1)
Storage temperature	Tstg	-55 ~ +125	°C	

(\*1) To use at a temperature higher than Ta=25°C, derate 5.0mW per 1°C.

Status of this document

The Japanese version of this document is the formal specification. A customer may use this translation version only for a reference to help reading the formal version. If there are any differences in translation version of this document, formal version takes priority.

Application example

The application circuit is recommended for use. Make sure to confirm the adequacy of the characteristics.

When using the circuit with changes to the external circuit constants, make sure to leave an adequate margin for external components including static and transitional characteristics as well as dispersion of the IC.

Note that ROHM cannot provide adequate confirmation of patents.

The product described in this specification is designed to be used with ordinary electronic equipment or devices (such as audio-visual equipment, office-automation equipment, communications devices, electrical appliances, and electronic toys.)

Should you intend to use this product with equipment or devices which require an extremely high level of reliability and the malfunction of which would directly endanger human life (such as medical instruments, transportation equipment, aerospace machinery, nuclear-reactor controllers, fuel controllers and other safety devices), please be sure to consult with our sales representative in advance.

ROHM assumes no responsibility for the use of any circuits described herein, conveys no license under any patent or other right, and makes no representations that the circuits are free from patent infringement.

○ Operating Range

Parameter	Symbol	Limits	Unit	Conditions
Operating supply voltage	V <sub>CC</sub>	4.5 ~ 5.5	V	Pin17, 25, 36
Operating temperature	T <sub>opr</sub>	-40 ~ +85	°C	
Audio input level	V <sub>IN-A</sub>	~ 500	mVrms	Pin 5, 7
Audio input frequency band	f <sub>IN-A</sub>	20 ~ 15k	Hz	Pin 5, 7
Transmission frequency	f <sub>TX</sub>	75 ~ 110	MHz	Pin 23, 24, 28
Control terminal "H" level input voltage	V <sub>IH</sub>	0.8V <sub>CC2</sub> ~ V <sub>CC2</sub>	V	Pin 30, 31, 32, 33
Control terminal "L" level input voltage	V <sub>IL</sub>	GND ~ 0.2V <sub>CC2</sub>	V	Pin 30, 31, 32, 33

○ Electrical Characteristics

Unless otherwise specified Ta=25°C , V<sub>CC</sub>=5.0V

Signal source : f<sub>IN</sub>=400Hz

Parameter	Symbol	Limits			Unit	Conditions
		Min.	Typ.	Max.		
Quiescent current	I <sub>Q</sub>	15	21	29	mA	
Channel separation	Sep	30	45	-	dB	V <sub>IN</sub> =125mVrms L→R, R→L
Total harmonic distortion	THD	-	0.1	0.3	%	V <sub>IN</sub> =125mVrms L+R
Channel balance	C.B	-1.5	0	+1.5	dB	V <sub>IN</sub> =125mVrms L+R
Input output gain 1	G <sub>V1</sub>	-4	-2	0	dB	V <sub>IN</sub> =125mVrms, EVR=0dB L+R
Input output gain 2	G <sub>V2</sub>	+2	+4	+6	dB	V <sub>IN</sub> =125mVrms, EVR=+6dB L+R
Input output gain 3	G <sub>V3</sub>	-10	-8	-6	dB	V <sub>IN</sub> =125mVrms, EVR=-6dB L+R
Limiter input level	V <sub>IN(LIM)</sub>	205	260	325	mVrms	Output distortion at 3% for input level
LPF attenuation volume 1	V <sub>O(LPF)1</sub>	-2	0.5	+1.5	dB	V <sub>IN</sub> =125mVrms f=10kHz
LPF attenuation volume 2	V <sub>O(LPF)2</sub>	-	-37	-30	dB	V <sub>IN</sub> =125mVrms f=19kHz
LPF attenuation volume 3	V <sub>O(LPF)3</sub>	-	-49	-35	dB	V <sub>IN</sub> =125mVrms f=38kHz
Signal to noise ratio	S/N	55	68	-	dB	V <sub>IN</sub> =125mVrms L+R
Sub carrier rejection ratio	SCR	-	-30	-20	dB	V <sub>IN</sub> =125mVrms L+R
Pilot output level	V <sub>OP</sub>	180	200	220	mV <sub>P-P</sub>	Pin 19
Mute attenuation volume	V <sub>O(MUTE)</sub>	-	-68	-60	dB	V <sub>IN</sub> =125mVrms L+R
Transmission output level	V <sub>TX</sub>	84	87	90	dB μV	f <sub>TX</sub> =100MHz
Transmission frequency precision	Δf <sub>TX</sub>	-3	0	+3	kHz	f <sub>TX</sub> =100MHz
"H" level input current	I <sub>IH</sub>	-	-	1.0	μA	Pin 30, 31, 32, 33 V <sub>IN</sub> =5V
"L" level input current	I <sub>IL</sub>	-1.0	-	-	μA	Pin 30, 31, 32, 33 V <sub>IN</sub> =0V
"H" level output voltage	V <sub>OH</sub>	V <sub>CC</sub> -1.0	V <sub>CC</sub> -0.3	-	V	Pin 20 I <sub>OUT</sub> =-1.0mA
"L" level output voltage	V <sub>OL</sub>	-	0.3	1.0	V	Pin 20 I <sub>OUT</sub> =1.0mA
"off" level leak current 1	I <sub>OFF1</sub>	-	-	100	nA	Pin 20 V <sub>OUT</sub> =5V
"off" level leak current 2	I <sub>OFF2</sub>	-100	-	-	nA	Pin 20 V <sub>OUT</sub> =GND
"L" level output voltage	V <sub>OL</sub>	-	0.2	1.0	V	Pin 29 I <sub>OUT</sub> =3.0mA
"off" level leak current	I <sub>OFF</sub>	-	-	1.0	μA	Pin 29 V <sub>OUT</sub> =5V

◎ This product is not designed for protection against radioactive rays.

◎ The specification of transmission output level be based on the Radio Law in every country and the area.

○ External Dimension Diagram • Marking Diagram

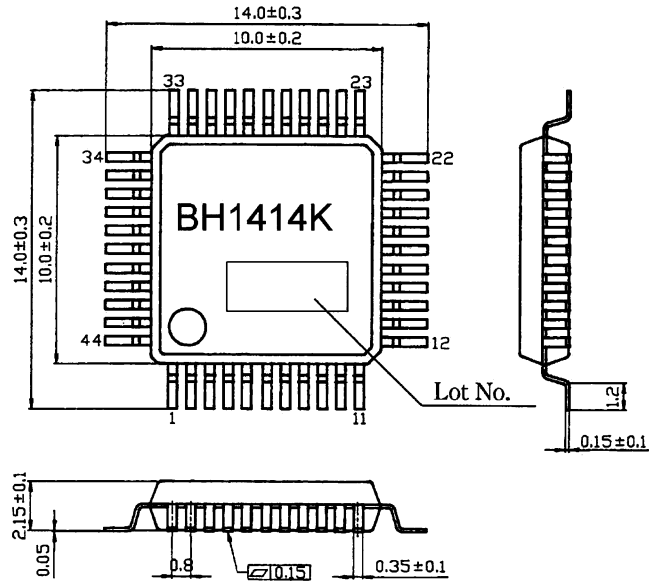

QFP-44(Unit : mm)

○ Block Diagram

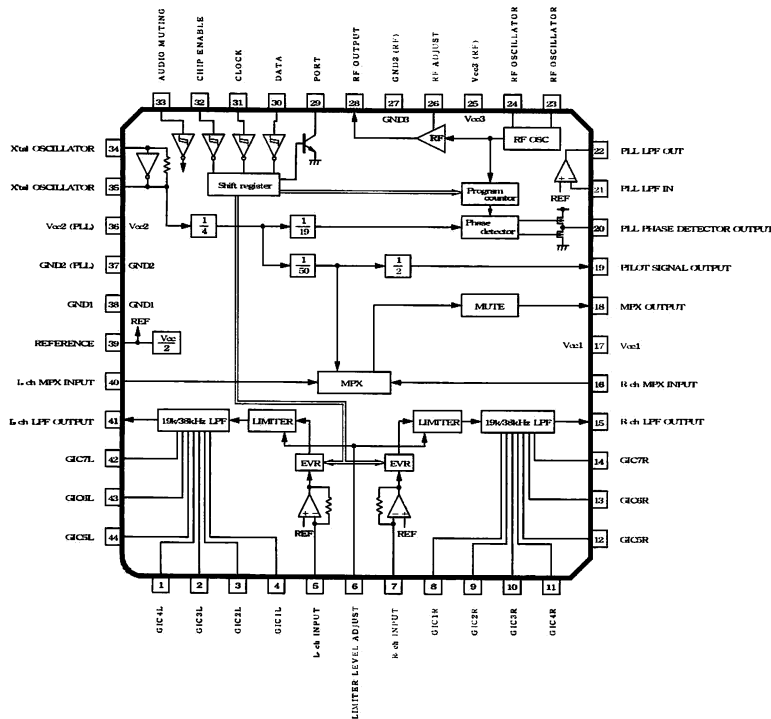

○ Pin No. • Pin Name

No.	Name	No.	Name
1	GIC4L	23	RF OSCILLATOR
2	GIC3L	24	RF OSCILLATOR
3	GIC2L	25	Vcc3 (RF)
4	GIC1L	26	RF ADJUST
5	L-ch INPUT	27	GND3 (RF)
6	LIMITER LEVEL ADJUST	28	RF OUTPUT
7	R-ch INPUT	29	POUT
8	GIC1R	30	DATA
9	GIC2R	31	CLOCK
10	GIC3R	32	CHIP ENABLE
11	GIC4R	33	AUDIO MUTING
12	GIC5R	34	X'tal OSCILLATOR
13	GIC6R	35	X'tal OSCILLATOR
14	GIC7R	36	Vcc2 (PLL)
15	R-ch LFP OUTPUT	37	GND2 (PLL)
16	R-ch MPX INPUT	38	GND1
17	Vcc1	39	REFERENCE
18	MPX OUTPUT	40	L-ch MPX INPUT
19	PILOT SIGNAL OUTPUT	41	L-ch MPX OUTPUT
20	PLL PHASE DETECTOR OUTPUT	42	GIC7L
21	PLL LFP IN	43	GIC6L
22	PLL LFP OUT	44	GIC5L

○ Cautions On Use

(1) Absolute maximum ratings

If applied voltage, operating temperature range, or other absolute maximum ratings are exceeded, the LSI may be damaged. Do not apply voltages or temperatures that exceed the absolute maximum ratings. If you think of a case in which absolute maximum ratings are exceeded, enforce fuses or other physical safety measures and investigate how not to apply the conditions under which absolute maximum ratings are exceeded to the LSI.

(2) GND potential

Make the GND pin voltage such that it is the lowest voltage even when operating below it. Actually confirm that the voltage of each pin does not become a lower voltage than the GND pin, including transient phenomena.

(3) Thermal design

Perform thermal design in which there are adequate margins by taking into account the allowable power dissipation in actual states of use.

(4) Shorts between pins and misinstallation

When mounting the LSI on a board, pay adequate attention to orientation and placement discrepancies of the LSI. If it is misinstalled and the power is turned on, the LSI may be damaged. It also may be damaged if it is shorted by a foreign substance coming between pins of the LSI or between a pin and a power supply or a pin and a GND.

(5) Operation in strong magnetic fields

Adequately evaluate use in a strong magnetic field, since there is a possibility of malfunction.

### Notes

- No technical content pages of this document may be reproduced in any form or transmitted by any means without prior permission of ROHM CO.,LTD.
- The contents described herein are subject to change without notice. The specifications for the product described in this document are for reference only. Upon actual use, therefore, please request that specifications to be separately delivered.
- Application circuit diagrams and circuit constants contained herein are shown as examples of standard use and operation. Please pay careful attention to the peripheral conditions when designing circuits and deciding upon circuit constants in the set.
- Any data, including, but not limited to application circuit diagrams information, described herein are intended only as illustrations of such devices and not as the specifications for such devices. ROHM CO.,LTD. disclaims any warranty that any use of such devices shall be free from infringement of any third party's intellectual property rights or other proprietary rights, and further, assumes no liability of whatsoever nature in the event of any such infringement, or arising from or connected with or related to the use of such devices.
- Upon the sale of any such devices, other than for buyer's right to use such devices itself, resell or otherwise dispose of the same, no express or implied right or license to practice or commercially exploit any intellectual property rights or other proprietary rights owned or controlled by
- ROHM CO., LTD. is granted to any such buyer.
- Products listed in this document are no antiradiation design.

The products listed in this document are designed to be used with ordinary electronic equipment or devices (such as audio visual equipment, office-automation equipment, communications devices, electrical appliances and electronic toys).

Should you intend to use these products with equipment or devices which require an extremely high level of reliability and the malfunction of which would directly endanger human life (such as medical instruments, transportation equipment, aerospace machinery, nuclear-reactor controllers, fuel controllers and other safety devices), please be sure to consult with our sales representative in advance.

#### About Export Control Order in Japan

Products described herein are the objects of controlled goods in Annex 1 (Item 16) of Export Trade Control Order in Japan.

In case of export from Japan, please confirm if it applies to "objective" criteria or an "informed" (by MITI clause) on the basis of "catch all controls for Non-Proliferation of Weapons of Mass Destruction.

Thank you for your accessing to ROHM product informations.  
More detail product informations and catalogs are available,  
please contact your nearest sales office.

Please contact our sales offices for details ;

U.S.A / San Diego	TEL : +1(858)625-3630	FAX : +1(858)625-3670
Atlanta	TEL : +1(770)754-5972	FAX : +1(770)754-0691
Dallas	TEL : +1(972)312-8818	FAX : +1(972)312-0330
Germany / Dusseldorf	TEL : +49(2154)9210	FAX : +49(2154)921400
United Kingdom / London	TEL : +44(1)908-282-666	FAX : +44(1)908-282-528
France / Paris	TEL : +33(0)1 56 97 30 60	FAX : +33(0) 1 56 97 30 80
China / Hong Kong	TEL : +852(2)740-6262	FAX : +852(2)375-8971
Shanghai	TEL : +86(21)6279-2727	FAX : +86(21)6247-2066
Dilian	TEL : +86(411)8230-8549	FAX : +86(411)8230-8537
Beijing	TEL : +86(10)8525-2483	FAX : +86(10)8525-2489
Taiwan / Taipei	TEL : +866(2)2500-6956	FAX : +866(2)2503-2869
Korea / Seoul	TEL : +82(2)8182-700	FAX : +82(2)8182-715
Singapore	TEL : +65-6332-2322	FAX : +65-6332-5662
Malaysia / Kuala Lumpur	TEL : +60(3)7958-8355	FAX : +60(3)7958-8377
Philippines / Manila	TEL : +63(2)807-6872	FAX : +63(2)809-1422
Thailand / Bangkok	TEL : +66(2)254-4890	FAX : +66(2)256-6334

Japan /  
(Internal Sales)

Tokyo	2-1-1, Yaesu, Chuo-ku, Tokyo 104-0082	TEL : +81(3)5203-0321	FAX : +81(3)5203-0300
Yokohama	2-4-8, Shin Yokohama, Kohoku-ku, Yokohama, Kanagawa 222-8575	TEL : +81(45)476-2131	FAX : +81(45)476-2128
Nagoya	Dainagayo Building 9F 3-28-12, Meieki, Nakamura-ku, Nagoya, Aichi 450-0002	TEL : +81(52)581-8521	FAX : +81(52)561-2173
Kyoto	579-32 Higashi Shiokouji-cho, Karasuma Nishi-iru, Shiokoujidori, Shimogyo-ku, Kyoto 600-8216	TEL : +81(75)311-2121	FAX : +81(75)314-6559

(Contact address for overseas customers in Japan)

Yokohama	TEL : +81(45)476-9270	FAX : +81(045)476-9271
----------	-----------------------	------------------------