

## HS40xx

High-Performance Relative Humidity and Temperature Sensor with Digital Output

The HS40xx series is a highly accurate, fully calibrated automotive-grade relative humidity and temperature sensor. While the HS400x devices come in a standard package with open air inlet, the HS401x devices feature a hydrophobic membrane, making it dust resistant and waterproof with IP67 rating. Both sensor versions, waterproof and non-waterproof, are available in two different accuracy classes, HS40x1 and HS40x3. The MEMS sensor features a proprietary sensor-level protection, ensuring high reliability and long-term stability.

Integrated calibration using a NIST traceable and verified production setup that is calibrated to ISO/IEC 17025 standards and temperature-compensation logic provides fully corrected RH and temperature values via a standard I<sup>2</sup>C output. No user calibration of the output data is required.

The high accuracy, fast measurement response time, and long-term stability combined with the small package size makes the HS40xx series ideal for a wide number of applications ranging from portable devices to products designed for harsh environments.

The HS40xx series digital sensor accurately measures relative humidity and temperature levels. The measured data is internally corrected and compensated for accurate operation over a wide range of temperature and humidity levels – user calibration is not required.

The ultra-low power consumption, micro-Watt, makes the HS40xx the ideal choice for portable and remote applications.

### Physical Characteristics

- Supply voltage: 1.71V to 3.6V
- Operating temperature: -40°C to +125°C
- 2.50 × 2.50 × 0.90 mm DFN-style 8-LGA package

### Product Image



### Features

- Humidity range: 0% to 100%RH
- Industrial grade, JEDEC qualified, -40°C to +125°C
- Automotive grade, AEC-Q100 qualified, Grade 2, -40°C to +105°C
- NIST traceability for relative humidity and temperature
- Hydrophobic membrane, IP67 rating (HS401x)
- Digital I<sup>2</sup>C output with CRC checksum
- RH accuracy: ±1.5%RH, typical (HS40x1)
- Temperature accuracy: ±0.2°C, typical (HS40x1, -10°C to +80°C)
- 14-bit resolution: 0.04%RH, typical
- Independent programmable resolution settings: 8, 10, 12, 14 bits
- Fast RH response time: 4 seconds time constant, typical
- Very low current consumption: 0.3μA average (8-bit resolution, 3.3V supply), 0.62μA average (14-bit resolution, 3.3V supply), one RH and temperature measurement per second
- Excellent stability against aging and volatile compounds
- Highly robust protection from harsh environmental conditions and mechanical shock

### Applications

- Climate control systems
- Instrumentation
- Home appliances
- Weather stations
- Building automation
- HVAC systems
- Medical equipment
- Data logging systems

## Contents

|  |           |
|--|-----------|
| <b>1. Pin Information</b>                                      | <b>4</b>  |
| 1.1 Pin Assignments  | 4         |
| 1.2 Pin Descriptions   | 4         |
| 1.3 Functional Diagram   | 4         |
| <b>2. Specifications</b>                                       | <b>5</b>  |
| 2.1 Absolute Maximum Ratings                                   | 5         |
| 2.2 Recommended Operating Conditions                           | 5         |
| <b>3. Humidity and Temperature Sensor Performance</b>          | <b>6</b>  |
| 3.1 Humidity Sensor Specification                              | 6         |
| 3.2 Temperature Sensor Specification                           | 6         |
| 3.3 Humidity Sensor Accuracy Graphs                            | 7         |
| 3.4 Temperature and Sensor Accuracy Graphs                     | 7         |
| <b>4. Sensor Interface</b>                                     | <b>8</b>  |
| 4.1 I <sup>2</sup> C Features and Timing                       | 8         |
| 4.2 Sensor Slave Address                                       | 8         |
| 4.3 I <sup>2</sup> C Communication                             | 9         |
| 4.4 Measurements and Commands                                  | 10        |
| 4.4.1 Performing a Hold Measurement                            | 10        |
| 4.4.2 Performing a No-Hold Measurement                         | 11        |
| 4.4.3 Calculating Humidity and Temperature Output              | 12        |
| 4.4.4 Measurement Conversion Times                             | 13        |
| 4.4.5 CRC Checksum Calculation                                 | 13        |
| 4.5 Periodic Measurement Mode                                  | 14        |
| 4.6 Alert Feature  | 14        |
| 4.6.1 Alert Pin – Measurement Active                           | 15        |
| 4.6.2 Alert Pin – Humidity and Temperature Threshold Detection | 15        |
| 4.7 Accessing Configurable HS40xx Registers                    | 17        |
| 4.7.1 Read Register Command                                    | 18        |
| 4.7.2 Write Register Command                                   | 18        |
| 4.8 Configuration Bits   | 19        |
| 4.8.1 Setting the Measurement Resolution                       | 19        |
| 4.8.2 Periodic Measurement Settings                            | 19        |
| 4.9 Reading the Sensor ID Number                               | 21        |
| 4.10 Resetting the Sensor                                      | 22        |
| <b>5. Conditioning</b>   | <b>22</b> |
| <b>6. Application Circuit</b>                                  | <b>23</b> |
| <b>7. Soldering Information</b>                                | <b>23</b> |
| <b>8. PCB Layout Guidelines</b>                                | <b>25</b> |
| <b>9. Storage and Handling</b>                                 | <b>25</b> |
| <b>10. Quality and Reliability</b>                             | <b>25</b> |
| <b>11. Package Outline Drawings</b>                            | <b>26</b> |

|                               |    |
|-------------------------------|----|
| 12. Marking Diagram .....     | 26 |
| 13. Ordering Information..... | 26 |
| 14. Revision History .....    | 26 |

## Figures

|   |    |
|---|----|
| Figure 1. Pin Assignments – Top View.....   | 4  |
| Figure 2. Functional Diagram of HS40xx.....   | 4  |
| Figure 3. HS40x1 RH Accuracy Tolerance at 25°C.....   | 7  |
| Figure 4. HS40x1 RH Accuracy over Temperature .....   | 7  |
| Figure 5. HS40x3 RH Accuracy Tolerance at 25°C.....   | 7  |
| Figure 6. HS40x3 RH Accuracy over Temperature .....   | 7  |
| Figure 7. HS40x3 Temperature Sensor Accuracy Tolerance .....  | 7  |
| Figure 8. HS40x1 Temperature Sensor Accuracy Tolerance .....  | 7  |
| Figure 9. Timing Diagram .....  | 8  |
| Figure 10. START and STOP Condition Waveform.....   | 9  |
| Figure 11. Typical Hold Measurement Sequence for a Humidity and Temperature Command.....                  | 11 |
| Figure 12. Typical No-Hold Measurement Sequence for a Humidity and Temperature Command .....              | 12 |
| Figure 13. Sequence to Retrieve the Latest Results in Periodic Measurement Mode.....                      | 14 |
| Figure 14. Sequence to Stop Periodic Measurements .....   | 14 |
| Figure 15. Alert Pin Function.....  | 15 |
| Figure 16. Alert Pin Functionality Example.....   | 16 |
| Figure 17. Data Returned from HS40xx when the Alert Feature is Enabled in Periodic Measurement Mode ..... | 16 |
| Figure 18. Read Register Command Sequence.....  | 18 |
| Figure 19. Write Register Command Sequence .....  | 18 |
| Figure 20. Read Sensor ID Command Sequence .....  | 22 |
| Figure 21. HS40xx Application Circuit – Top View .....  | 23 |
| Figure 22. Recommended Soldering Profile.....   | 24 |
| Figure 23. Milled PCB Openings for Thermal Isolation.....   | 25 |

## Tables

|   |    |
|---|----|
| Table 1. Absolute Maximum Ratings for HS40xx Sensors .....  | 5  |
| Table 2. Operating Conditions for HS40xx Sensors.....   | 5  |
| Table 3. Humidity Sensor Specification, $T_A = +25^{\circ}\text{C}$ , $V_{DD} = 1.71\text{V}$ to $3.6\text{V}$ .....    | 6  |
| Table 4. Temperature Sensor Specification, $T_A = +25^{\circ}\text{C}$ , $V_{DD} = 1.71\text{V}$ to $3.6\text{V}$ ..... | 6  |
| Table 5. I <sup>2</sup> C Timing Parameters .....   | 8  |
| Table 6. Commands Code and Description.....   | 9  |
| Table 7. Measurement Command Modes .....  | 10 |
| Table 8. Conversion Times.....  | 13 |
| Table 9. CRC Checksum Properties.....   | 13 |
| Table 10. Alert Status Bits.....  | 17 |
| Table 11. Temperature and Humidity Measurement Resolution Settings.....   | 19 |
| Table 12. Periodic Measurement Settings.....  | 19 |
| Table 13. Alert Feature Settings.....   | 20 |

# 1. Pin Information

## 1.1 Pin Assignments

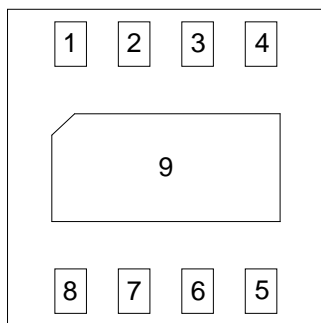

Figure 1. Pin Assignments – Top View

## 1.2 Pin Descriptions

| Pin Number | Pin Name          | Type   | Description   |
|------------|-------------------|--------|---|
| 1          | SDA               | In/Out | Serial data.  |
| 2          | NC <sup>[1]</sup> | -      | Connect to VSS, VDD or leave floating                                   |
| 3          | ALERT             | Out    | Digital output indicating an alarm condition. Leave floating if unused. |
| 4          | SCL               | In/Out | Serial clock.   |
| 5          | VDD               | In     | Supply voltage.   |
| 6          | NC <sup>[1]</sup> | -      | Connect to VSS, VDD or leave floating                                   |
| 7          | NC <sup>[1]</sup> | -      | Connect to VSS, VDD or leave floating                                   |
| 8          | VSS               | In     | Ground.   |
| 9          | EPAD              | -      | Connect to VSS or leave floating  |

1. "NC" stands for not connected.

## 1.3 Functional Diagram

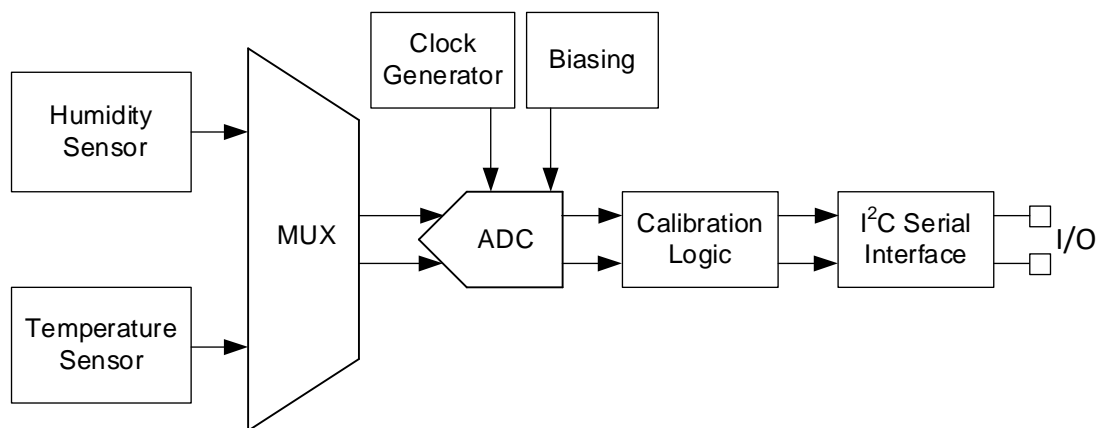

Figure 2. Functional Diagram of HS40xx

## 2. Specifications

### 2.1 Absolute Maximum Ratings

*Caution:* The absolute maximum ratings are stress ratings only. Stresses greater than those listed below can cause permanent damage to the device. Functional operation of the HS40xx at absolute maximum ratings is not implied. Exposure to absolute maximum rating conditions might affect device reliability.

**Table 1. Absolute Maximum Ratings for HS40xx Sensors**

| Parameter                 | Conditions            | Minimum | Maximum | Unit |
|---------------------------|-----------------------|---------|---------|------|
| Supply Voltage            | -                     | -0.3    | 3.6     | V    |
| Storage Temperature Range | Recommended 0 to 60°C | -40     | 125     | °C   |

### 2.2 Recommended Operating Conditions

*Important:* The HS40xx series sensors are optimized to perform best in the more common temperature and humidity ranges of 10°C to 50°C and 20% RH to 80% RH, respectively. If operated outside of these conditions for extended periods, especially at high humidity levels, the sensors may exhibit an offset. In most cases, this offset is temporary and will gradually disappear once the sensor is returned to normal temperature and humidity conditions. The amount of the shift and the duration of the offset vary depending on the duration of exposure and the severity of the relative humidity and temperature conditions.<sup>[1]</sup> The time needed for the offset to disappear can also be decreased by using the procedures described in sections 9 and 10.

**Table 2. Operating Conditions for HS40xx Sensors**

| Parameter                   | Condition   |                   | Minimum | Typical | Maximum | Unit |
|-----------------------------|---|-------------------|---------|---------|---------|------|
| Operating Supply Voltage    | -   |                   | 1.71    | 3.3     | 3.6     | V    |
| Sleep Current               | Sleep Mode  | 25°C              | -       | 0.010   | 0.025   | µA   |
|                             |   | -40 to 125°C      | -       | -       | 2.5     |      |
| Average Current             | One RH + temperature measurement/second<br>V <sub>DD</sub> = 3.3V | 8-bit resolution  | 0.27    | 0.30    | 0.32    | µA   |
|                             |   | 10-bit resolution | 0.31    | 0.34    | 0.37    |      |
|                             |   | 12-bit resolution | 0.39    | 0.43    | 0.47    |      |
|                             |   | 14-bit resolution | 0.55    | 0.62    | 0.69    |      |
| Measurement Time            | Humidity and temperature including the digital compensation       | 8-bit resolution  | -       | 0.64    | -       | ms   |
|                             |   | 10-bit resolution | -       | 0.80    | -       |      |
|                             |   | 12-bit resolution | -       | 1.04    | -       |      |
|                             |   | 14-bit resolution | -       | 1.70    | -       |      |
| Operating Temperature Range | -   |                   | -40     | -       | 125     | °C   |

1. At T<sub>A</sub> = +25°C, V<sub>DD</sub> = +1.71V to +3.6V unless otherwise specified.

### 3. Humidity and Temperature Sensor Performance

#### 3.1 Humidity Sensor Specification

Table 3. Humidity Sensor Specification, T<sub>A</sub> = +25°C, V<sub>DD</sub> = 1.71V to 3.6V

| Parameter   | Condition               |              | Minimum | Typical | Maximum | Unit   |
|---|-------------------------|--------------|---------|---------|---------|--------|
| Range   | -                       |              | 0       | -       | 100     | %RH    |
| Accuracy <sup>[1][2]</sup>                              | HS40x1                  | 10% to 90%RH | -       | ±1.5    | -       | %RH    |
|   | HS40x3                  | 20% to 80%RH | -       | ±2.5    | -       |        |
| Resolution  | 14-bit                  |              | -       | 0.04    | 0.05    | %RH    |
| Hysteresis  | -                       |              | -       | -       | ±1.0    | %RH    |
| Non-Linearity from Response Curve                       | HS40x1                  | 10% to 90%RH | -       | ±0.15   | -       | %RH    |
|   | HS40x3                  | 20% to 80%RH |         |         |         |        |
| Long-Term Stability                                     | -                       |              | -       | ±0.1    | -       | %RH/Yr |
| Response Time Constant <sup>[3]</sup> (τ <sub>H</sub> ) | 20% to 80% RH Still Air |              | 3.0     | 4.0     | 6.0     | sec    |

1. Monotonic increases from 10% to 90% RH after sensor has been stabilized at 50% RH.
2. For more information, see section 3.3.
3. Initial value to 63% of total variation. Response time depend on system airflow.

#### 3.2 Temperature Sensor Specification

Table 4. Temperature Sensor Specification, T<sub>A</sub> = +25°C, V<sub>DD</sub> = 1.71V to 3.6V

| Parameter   | Condition |               | Minimum | Typical | Maximum | Unit  |
|---|-----------|---------------|---------|---------|---------|-------|
| Range   | -         |               | -40     | -       | 125     | °C    |
| Accuracy <sup>[1]</sup>                                 | HS40x1    | -10°C to 80°C | -       | ±0.2    | -       | °C    |
|   | HS40x3    | 0°C to 70°C   | -       | ±0.25   | -       |       |
| Resolution  | 14-bit    |               | -       | 0.01    | -       | °C    |
| Response Time Constant <sup>[2]</sup> (τ <sub>T</sub> ) | -         |               | -       | >2.0    | -       | Sec.  |
| Long-Term Stability                                     | -         |               | -       | -       | 0.03    | °C/Yr |
| Supply Voltage Dependency <sup>[3]</sup>                | -         |               | -       | 0.03    | 0.1     | °C/V  |

1. For more information, see section 3.4.
2. Initial value to 63% of total variation. Response time depends on system thermal mass and air flow.
3. Temperature accuracy can be optimized for specified supply voltages upon request.

### 3.3 Humidity Sensor Accuracy Graphs

The typical and maximum relative humidity sensor accuracy tolerances are shown in the following figures.

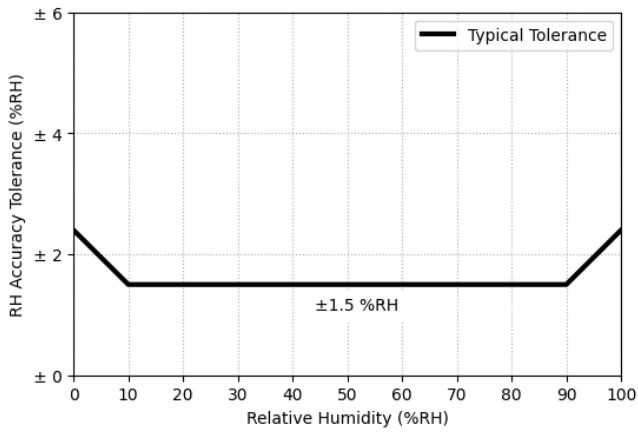

Figure 3. HS40x1 RH Accuracy Tolerance at 25°C

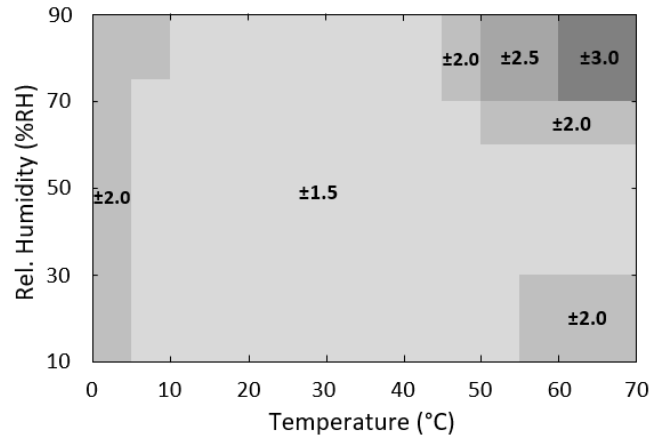

Figure 4. HS40x1 RH Accuracy over Temperature

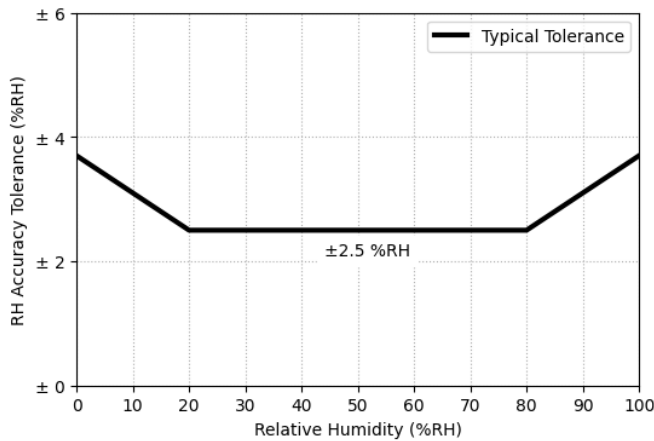

Figure 5. HS40x3 RH Accuracy Tolerance at 25°C

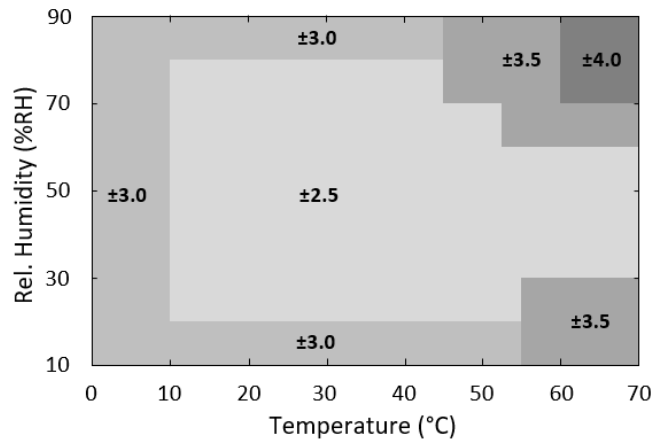

Figure 6. HS40x3 RH Accuracy over Temperature

### 3.4 Temperature and Sensor Accuracy Graphs

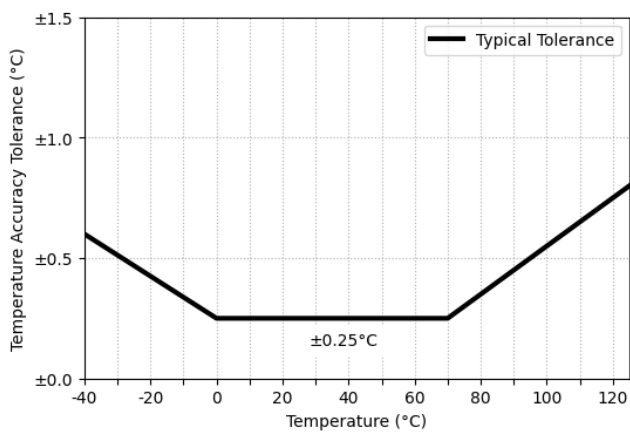

Figure 7. HS40x3 Temperature Sensor Accuracy Tolerance

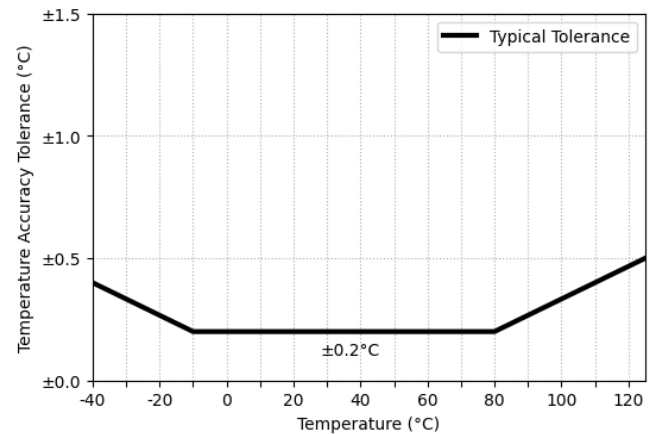

Figure 8. HS40x1 Temperature Sensor Accuracy Tolerance

## 4. Sensor Interface

The HS40xx series sensor uses a digital I<sup>2</sup>C-compatible communication protocol. To accommodate multiple devices, the protocol uses two bi-directional open-drain lines: the Serial Data Line (SDA) and the Serial Clock Line (SCL). Pull-up resistors to V<sub>DD</sub> are required. Several slave devices can share the bus; however, only one master device can be present on the line.

### 4.1 I<sup>2</sup>C Features and Timing

The HS40xx series sensor operates as a slave device on the I<sup>2</sup>C bus with support for 100kHz and 400kHz bit rates. Each transmission is initiated when the master sends a 0 START bit (S), and the transmission is terminated when the master sends a 1 STOP bit (P). These bits are exclusively transmitted while the SCL line is high.

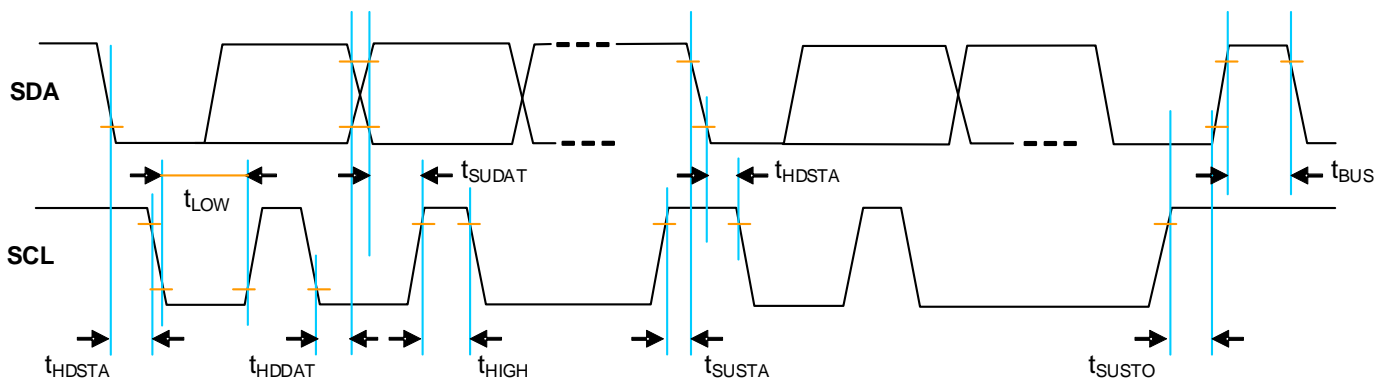

Figure 9. Timing Diagram

Table 5. I<sup>2</sup>C Timing Parameters

| Parameter  | Symbol             | Minimum | Typical | Maximum | Unit |
|--|--------------------|---------|---------|---------|------|
| SCL Clock Frequency                                      | f <sub>SCL</sub>   | 0       | -       | 400     | kHz  |
| START Condition Hold Time Relative to SCL Edge           | t <sub>HDSTA</sub> | 0.1     | -       | -       | μs   |
| Minimum SCL Clock LOW Width <sup>[4]</sup>               | t <sub>LOW</sub>   | 0.6     | -       | -       | μs   |
| Minimum SCL Clock HIGH Width <sup>[4]</sup>              | t <sub>HIGH</sub>  | 0.6     | -       | -       | μs   |
| START Condition Setup Time Relative to SCL Edge          | t <sub>SUSTA</sub> | 0.1     | -       | -       | μs   |
| Data Hold Time on SDA Relative to SCL Edge               | t <sub>HDDAT</sub> | 0       | -       | 0.5     | μs   |
| Data Setup Time on SDA Relative to SCL Edge              | t <sub>SUDAT</sub> | 0.1     | -       | -       | μs   |
| STOP Condition Setup Time on SCL                         | t <sub>SUSTO</sub> | 0.1     | -       | -       | μs   |
| Bus Free Time Between STOP Condition and START Condition | t <sub>BUS</sub>   | 1       | -       | -       | μs   |

1. Combined LOW and HIGH widths must equal or exceed the minimum SCL period.

### 4.2 Sensor Slave Address

The HS40xx series default I<sup>2</sup>C address is 54<sub>HEX</sub>. The device will respond only to this 7-bit address (for more information, see section 10.1).



### 4.3 I<sup>2</sup>C Communication

The sensor transmission is initiated when the master sends a 0 START bit (S). The transmission is terminated when the master sends a 1 STOP bit (P). These bits are only transmitted while the SCL line is HIGH (see Figure 10 for waveforms).

Once the START condition has been set, the SCL line is toggled at the prescribed data rate, clocking subsequent data transfers. Data on the SDA line is always sampled on the rising edge of the SCL line and must remain stable while SCL is HIGH to prevent false START or STOP conditions.

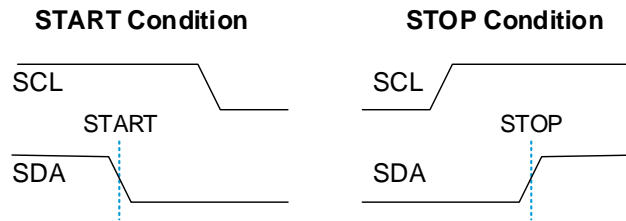

Figure 10. START and STOP Condition Waveform

After the START bit, the master device sends the 7-bit slave address (see section 4.2) to the HS40xx, followed by the read/write bit, which indicates the transfer direction of any subsequent data. This bit is set to 1 to indicate a read from slave to master or set to 0 to indicate a write from master to slave.

All transfers consist of 8 bits and a response bit: 0 for Acknowledge (ACK) or 1 for Not Acknowledge (NACK). After the ACK is received, another data byte can be transferred or the communication can be stopped with a STOP bit.

The HS40xx series sensors are equipped with different commands to configure the chip and to perform measurement as described in Table 6.

Table 6. Commands Code and Description

| Command Code (HEX) | Description                                  |
|--------------------|--|
| 0xE3               | Hold Temperature Measurement                 |
| 0xF3               | No-hold Temperature Measurement              |
| 0xE5               | Hold Humidity and Temperature Measurement    |
| 0xF5               | No-hold Humidity and Temperature Measurement |
| 0xA7               | Read Register                                |
| 0xA6               | Write Register                               |
| 0x30               | Stop Periodic Measurements                   |
| 0xD7               | Read Sensor ID                               |

The Hold and No-hold commands are described in section 4.4, and the read and write register commands are described in section 4.7. The HS40xx sensor can measure only temperature or both humidity and temperature as described in Table 7. Both options return fully calibrated measurements that can be converted to humidity and temperature readings using the equations in section 4.4.3. To soft reset the sensor, see section 4.10.

Table 7. Measurement Command Modes

| Measurement Command Mode | Description   | Number of Data Bytes Sent on the I <sup>2</sup> C Bus |
|--------------------------|---|---|
| Temperature              | The chip only measures temperature and sends the 14-bit result once the measurement is complete.  | 2 bytes + 1 byte CRC                                  |
| Humidity and Temperature | The chip measures humidity and temperature and sends the 14-bit humidity result followed by the 14-bit temperature result once the measurement is complete. | 4 bytes + 1 byte CRC                                  |

## 4.4 Measurements and Commands

There are two types of measurement commands:

1. **Hold Measurement commands** – The HS40xx series sensor holds the SCL line low during the measurement and releases the SCL line when the measurement is complete. This lets the master know exactly when the measurement has finished. Using this mode will prevent the master from communicating with any other slave until the measurement is complete. Note that the minimum frequency for the SCL clock in this mode is 200kHz.
2. **No-hold Measurement commands** – The HS40xx series sensor does not hold the SCL line low, and the master is free to initiate communication with other slaves while the chip is performing the measurement. To obtain the measurement data, the master must request the result from the chip after the expected conversion time which depends on the measurement resolution as summarized in section 4.4.4. There is no minimum clock frequency when in this mode.

### 4.4.1 Performing a Hold Measurement

A hold measurement sequence consists of the following steps, as displayed in Figure 11. The minimum SCL clock frequency in this mode is 200kHz.

1. Wake up the HS40xx series sensor from sleep mode by sending its I<sup>2</sup>C address with a write bit and initiate a measurement by sending the desired hold measurement command.
2. Change the direction of communication by sending a start bit, the HS40xx I<sup>2</sup>C address, and a read bit. The SCL line is held low by the sensor during the measurement process, which prevents the master from initiating any communications with other slaves on the bus.

Once the requested measurement is completed by the HS40xx series sensor, the SCL line is released and the chip waits for the SCL clock signal to send the results. The sensor will then transmit the requested measurement data on the bus for the master to capture and enters sleep mode again after 20μs.

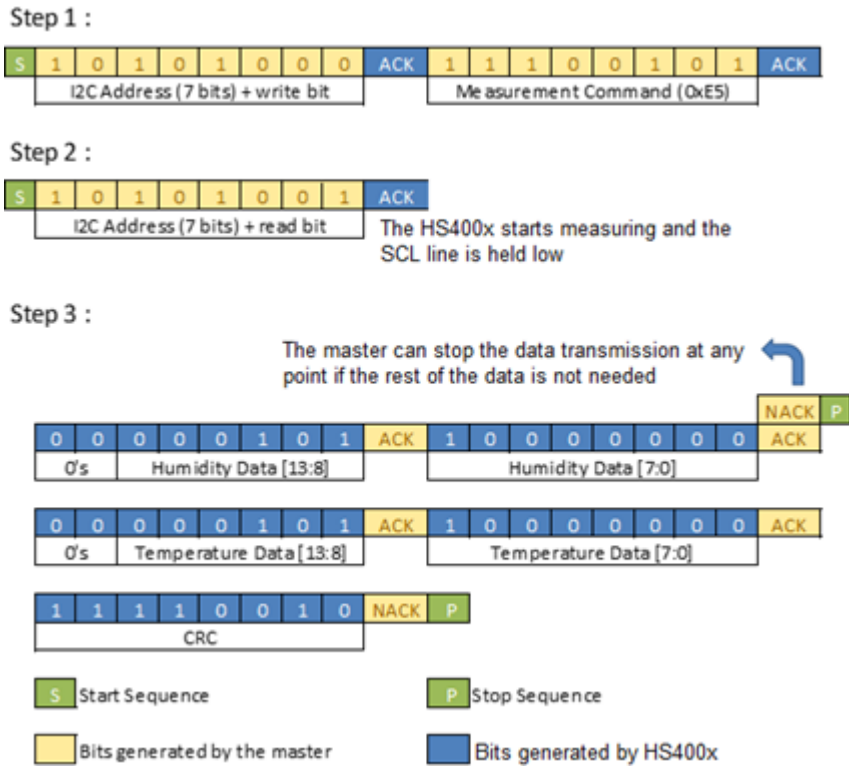

Figure 11. Typical Hold Measurement Sequence for a Humidity and Temperature Command

#### 4.4.2 Performing a No-Hold Measurement

A no-hold measurement sequence consists of the following steps, as displayed in Figure 12.

1. Wake up the HS40xx series sensor from sleep mode by sending its I<sup>2</sup>C address with a write bit and initiate a measurement by sending the desired no-hold measurement command.
2. To read the result from the HS40xx series sensor, the master has to send the chip its I<sup>2</sup>C address and a read bit. If the measurement is completed and the result is ready, the chip will send an ACK bit and start to send the result over the bus and then enter sleep mode again after 20µs. If the measurement is still in progress, the chip will send a NACK bit and the master will need to try to read the result again.

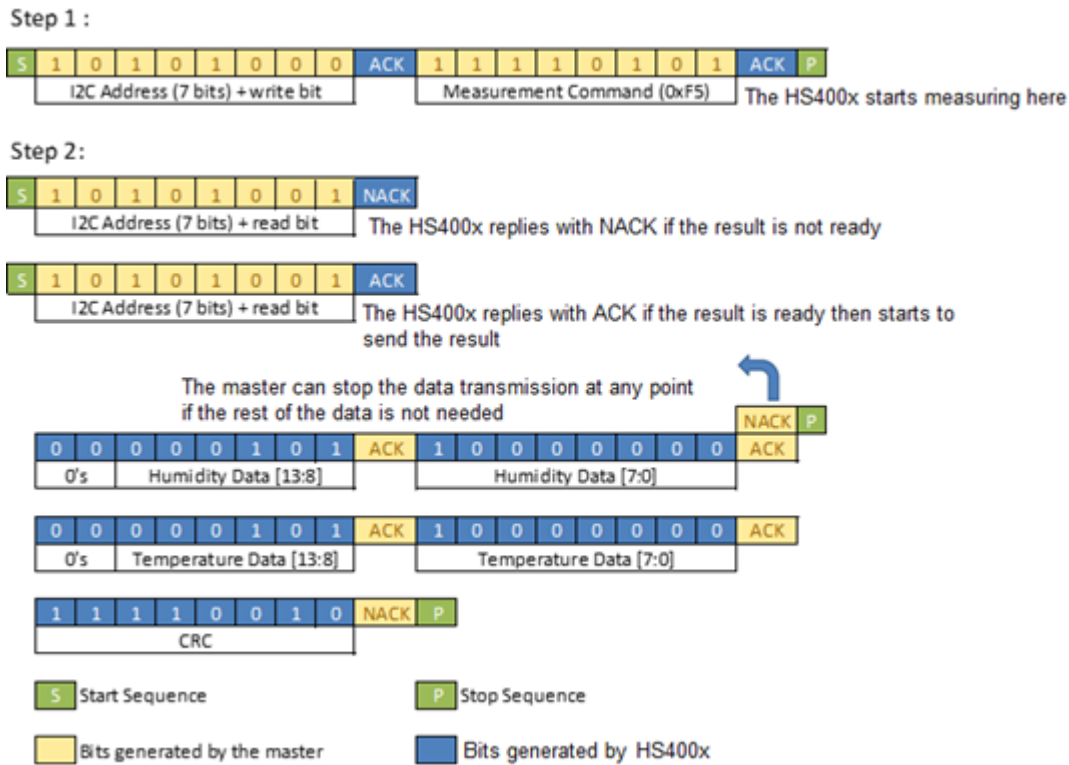

Figure 12. Typical No-Hold Measurement Sequence for a Humidity and Temperature Command

### 4.4.3 Calculating Humidity and Temperature Output

As indicated in Table 7, the measurement data can be either two or four bytes long depending on whether a temperature measurement or a humidity and temperature measurement was initiated. The most significant bit of the reading is sent first followed by the least significant bits. The humidity and temperature measurements are always scaled up to a 14-bit value regardless of the selected resolution of the sensor. The relative humidity (in percent) and the temperature (in degrees Celsius) are obtained as follows:

The relative humidity (in percent) and the temperature (in degrees Celsius) are calculated with Equation 1 and Equation 2, respectively.

$$Humidity [\%RH] = \frac{Humidity[13:0]}{2^{14} - 1} * 100 \tag{Equation 1}$$

$$Temperature [^{\circ}C] = \frac{Temperature [13:0]}{2^{14} - 1} * 165 - 40 \tag{Equation 2}$$

#### 4.4.4 Measurement Conversion Times

The HS40xx series sensors are designed to have relatively fast conversion times. The conversion time depends on the resolution of the measurement and the command type (temperature or humidity and temperature). Table 8 summarizes the conversion times for different resolutions.

**Table 8. Conversion Times**

| Measurement                             | Resolution (bits) | Measurement Time (ms) |
|---|-------------------|-----------------------|
| Temperature                             | 8                 | 0.37                  |
|   | 10                | 0.45                  |
|   | 12                | 0.60                  |
|   | 14 (default)      | 0.91                  |
| Humidity and Temperature <sup>[1]</sup> | 8                 | 0.64                  |
|   | 10                | 0.80                  |
|   | 12                | 1.04                  |
|   | 14 (default)      | 1.70                  |

1. Assuming the same resolution settings for both humidity and temperature measurements.

#### 4.4.5 CRC Checksum Calculation

An 8-bit CRC checksum is transmitted after each measurement so that the user can check for data corruption during communications if desired. The properties of the CRC algorithm used are summarized in Table 9, and the CRC is based on all 4 bytes of measurement data (2 bytes of humidity data followed by 2 bytes of temperature data). For temperature-only measurements, the 2 bytes of humidity data are set to be all zeros for the CRC calculation.

**Table 9. CRC Checksum Properties**

| Property         | Value                                |
|------------------|--------------------------------------|
| Input Data Width | 32 bits                              |
| CRC Width        | 8 bits                               |
| Polynomial       | 0x1D ( $x^8 + x^4 + x^3 + x^2 + 1$ ) |
| Initial Value    | 0xFF                                 |
| Final XOR Value  | 0x00                                 |
| Reflect Input    | No                                   |
| Reflect Output   | No                                   |
| Example          | CRC (0x05800580) = 0xF2              |

### 4.5 Periodic Measurement Mode

The HS40xx sensors can also be configured to measure at regular intervals without user intervention, and the process to enable this mode is described in section 4.8.2. In this mode, the user can read the latest relative humidity / temperature data by issuing a data fetch sequence, which consists of sending the HS40xx I<sup>2</sup>C address with a read bit. The sensor will then send the latest measurement result over the I<sup>2</sup>C bus. The data fetch sequence is displayed in Figure 13.

Step 1 :

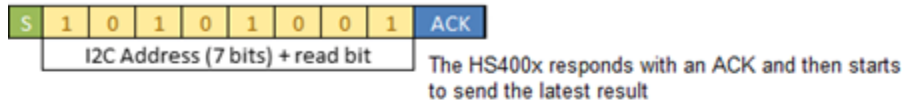

Step 2:

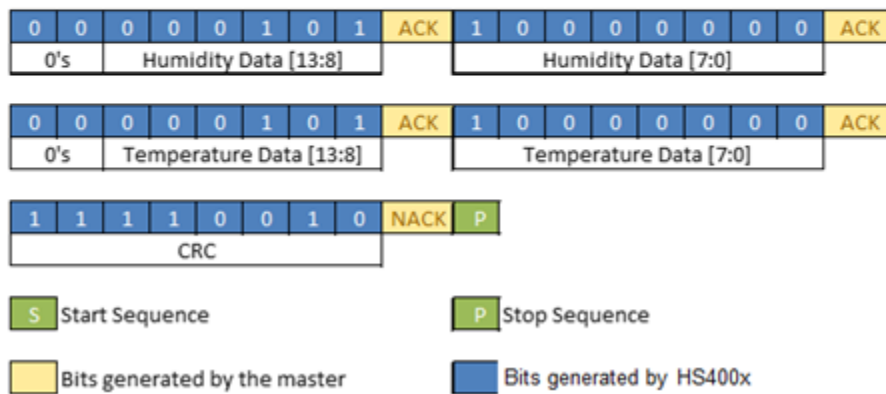

Figure 13. Sequence to Retrieve the Latest Results in Periodic Measurement Mode

The frequency of the periodic measurements can be set using the configuration registers. Section 4.7 describes how these registers are accessed, and section 4.8.2 provides the register settings needed to configure and activate the periodic measurements.

When the periodic measurement mode is active, the only commands the chip will respond to are the data fetch command, and a command to stop the periodic measurements. The sensor will not enter sleep mode while in periodic measurement mode. The command to stop periodic measurements is issued by sending the I<sup>2</sup>C address with a write bit, followed by the command 0x30, as shown in Figure 14. Once the periodic measurements have been stopped, the chip returns to sleep and is ready to accept all valid I<sup>2</sup>C commands.

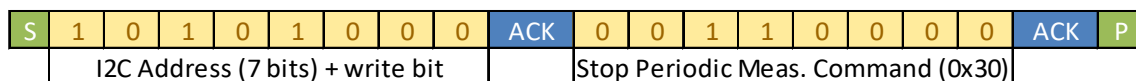

Figure 14. Sequence to Stop Periodic Measurements

### 4.6 Alert Feature

The HS40xx sensors have an optional Alert feature that can be configured in the following two ways:

1. The Alert pin can be used to indicate when a measurement is active in periodic measurement mode. This is the default behavior of the Alert pin upon power-up.
2. The Alert pin can be used to trigger an interrupt on the system microcontroller so an appropriate action can be taken if the temperature or humidity is outside of the desired limits.

These features are described in the following two sub-sections.

### 4.6.1 Alert Pin – Measurement Active

The default behavior of the Alert pin is to indicate when a measurement is active if periodic measurement mode is used. Upon power-up, the Alert pin will have a logic high level. When periodic measurement mode is activated, the Alert pin will have a logic low level between measurements and a logic high during measurements. This behavior is shown in Figure 15, and the Alert pin will exhibit this functionality when the temperature and humidity alerts are disabled (see Table 13).

If periodic measurement mode is not active, the Alert pin will remain at a logic high level.

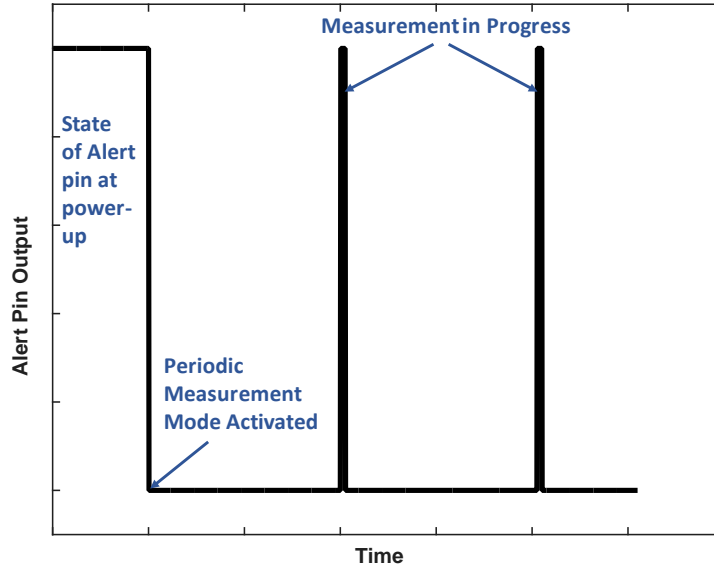

Figure 15. Alert Pin Function

### 4.6.2 Alert Pin – Humidity and Temperature Threshold Detection

The Alert pin can also be configured to send a signal when a humidity / temperature threshold is exceeded, and the system needs to respond. In this mode, the Alert feature has a programmable threshold, polarity, and hysteresis, and can apply to both temperature and humidity measurements. An example of the functionality of the Alert feature is displayed in Figure 16.

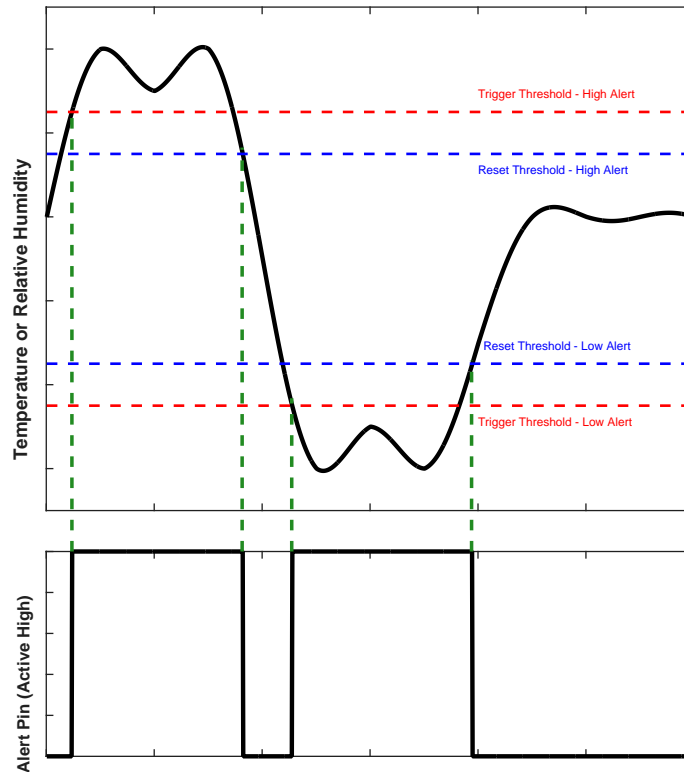

Figure 16. Alert Pin Functionality Example

The registers used to enable the Alert feature and the temperature / humidity thresholds are shown in Table 11. When the Alert feature is enabled for either humidity or temperature in periodic measurement mode, an additional status byte will precede the measurement values. The format of the bits are returned from the HS40xx sensor when any Alert is enabled as shown in Figure 17.

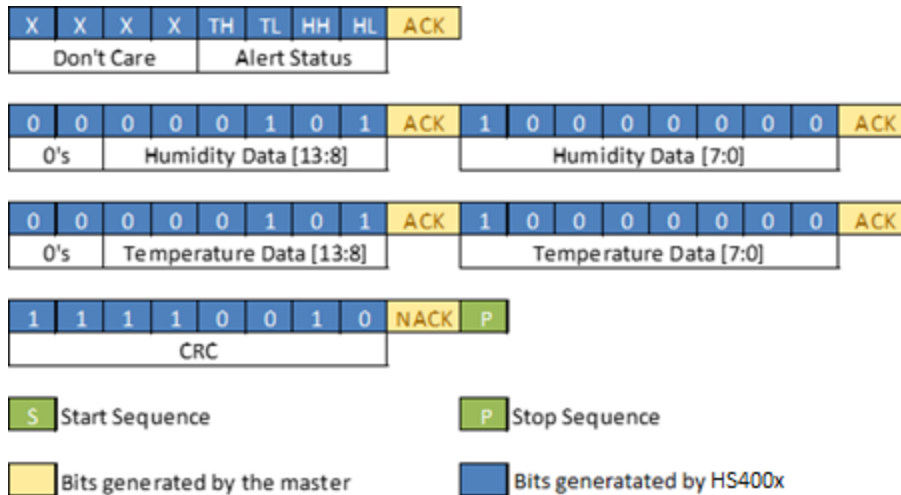

Figure 17. Data Returned from HS40xx when the Alert Feature is Enabled in Periodic Measurement Mode

The meaning of the Alert status bits are defined in Table 10.



**Table 10. Alert Status Bits**

| Status Bit | Meaning   |
|------------|---|
| TH         | High (0b1) if the Temperature High Alert is triggered |
| TL         | High (0b1) if the Temperature Low Alert is triggered  |
| HH         | High (0b1) if the Humidity High Alert is triggered    |
| HL         | High (0b1) if the Humidity Low Alert is triggered     |

## 4.7 Accessing Configurable HS40xx Registers

The HS40xx measurement settings can be changed by accessing the appropriate configuration registers and altering their values. This can be done by issuing a Write Register command. A Read Register command is also available to read the configuration register values. These commands are described in this section, and the configuration registers and settings are described in section 4.8.

While accessing specific configuration bits in any register, all the other bits in that register must be left unchanged. To write a specific bit/bits in a register, the process is as follows:

1. Read the entire configuration register using the sequence described in section 4.7.1.
2. Mask the register such that only the required bits are changed according to the configuration parameters in section 4.8.
3. Write the new register back to the appropriate address using the Write Register command sequence described in section 4.7.2.

All configuration registers will be reset to their default values if the power supply to the chip is cut off.

### 4.7.1 Read Register Command

A Read Register sequence consists of the following steps, as illustrated in Figure 18.

1. Wake up the HS40xx series sensor from sleep mode by sending its I<sup>2</sup>C address with a write bit and initiate a Read Register command by sending the command 0xA7.
2. Send the address of the register to be read.
3. Change the direction of communication by sending the HS40xx I<sup>2</sup>C address and a read bit. The chip will send the data stored in this register, after which the master replies with a NACK and a STOP bit.

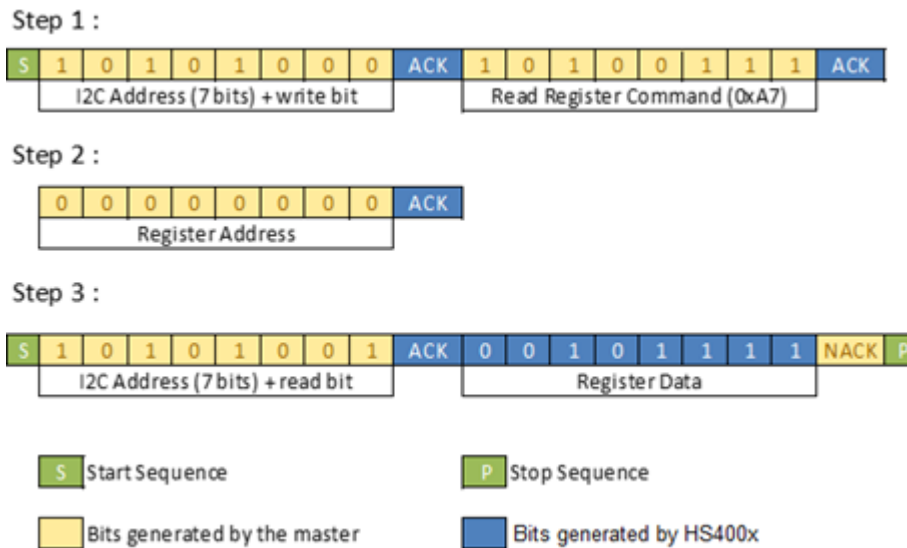

Figure 18. Read Register Command Sequence

### 4.7.2 Write Register Command

A Write Register sequence consists of the following steps, as illustrated in Figure 19.

1. Wake up the HS40xx series sensor from sleep mode by sending its I<sup>2</sup>C address with a write bit and initiate a Write Register command by sending the command 0xA6.
2. Send the address of the register to write.
3. Send the data to be stored in this register followed by a STOP bit.

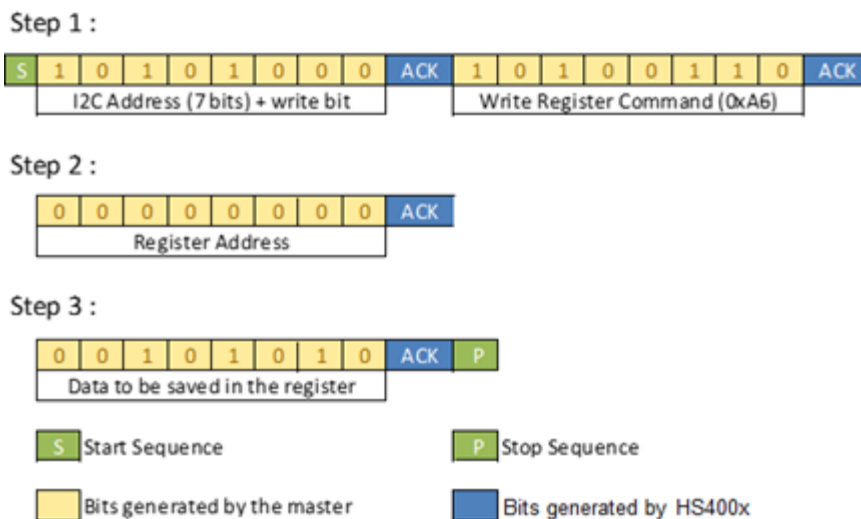

Figure 19. Write Register Command Sequence

## 4.8 Configuration Bits

### 4.8.1 Setting the Measurement Resolution

The HS40xx can be configured to perform measurements at different humidity and temperature resolutions by using the Read and Write Register commands with the appropriate register address. There are four separate resolution settings for the temperature and humidity measurements, as summarized in Table 11.

**Table 11. Temperature and Humidity Measurement Resolution Settings**

| Setting                                | Register Address (HEX) | Bits | Description                |
|--|------------------------|------|----------------------------|
| Resolution for Temperature Measurement | 0x00                   | 1:0  | 0b00 for 8 bits            |
|  |                        |      | 0b01 for 10 bits           |
|  |                        |      | 0b10 for 12 bits           |
|  |                        |      | 0b11 for 14 bits (default) |
| Resolution for Humidity Measurement    | 0x00                   | 3:2  | 0b00 for 8 bits            |
|  |                        |      | 0b01 for 10 bits           |
|  |                        |      | 0b10 for 12 bits           |
|  |                        |      | 0b11 for 14 bits (default) |

### 4.8.2 Periodic Measurement Settings

The registers that are used to activate and configure the periodic measurement settings are shown in Table 12.

**Table 12. Periodic Measurement Settings**

| Setting                            | Register Address (HEX) | Bits | Description                                    |
|------------------------------------|------------------------|------|--|
| Activate Periodic Measurements     | 0x02                   | 7    | 0b0 when periodic measurements are deactivated |
|                                    |                        |      | 0b1 to activate periodic measurements          |
| Frequency of Periodic Measurements | 0x02                   | 5:4  | 0b00 for a measurement every 0.5s              |
|                                    |                        |      | 0b01 for a measurement every 1s (default)      |
|                                    |                        |      | 0b10 for a measurement every 2.5s              |

**Table 13. Alert Feature Settings**

| Setting   | Register Address (HEX) | Bits | Description   |               |   |   |                          |   |   |   |               |   |   |   |   |   |  |   |   |   |   |   |   |   |   |   |   |   |   |   |   |   |   |   |     |  |  |  |  |  |  |                          |  |  |  |  |  |  |  |  |  |  |  |  |  |                         |  |  |  |  |  |  |
|---|------------------------|------|---|---------------|---|---|--------------------------|---|---|---|---------------|---|---|---|---|---|--|---|---|---|---|---|---|---|---|---|---|---|---|---|---|---|---|---|-----|--|--|--|--|--|--|--------------------------|--|--|--|--|--|--|--|--|--|--|--|--|--|-------------------------|--|--|--|--|--|--|
| Alert Pin Polarity In Humidity/Temperature Threshold Detection Mode | 0x02                   | 0    | 0b0 Alert pin is active high when triggered   |               |   |   |                          |   |   |   |               |   |   |   |   |   |  |   |   |   |   |   |   |   |   |   |   |   |   |   |   |   |   |   |     |  |  |  |  |  |  |                          |  |  |  |  |  |  |  |  |  |  |  |  |  |                         |  |  |  |  |  |  |
|   |                        |      | 0b1 Alert pin is active low when triggered (default)  |               |   |   |                          |   |   |   |               |   |   |   |   |   |  |   |   |   |   |   |   |   |   |   |   |   |   |   |   |   |   |   |     |  |  |  |  |  |  |                          |  |  |  |  |  |  |  |  |  |  |  |  |  |                         |  |  |  |  |  |  |
| Alert Enable Settings   | 0x03                   | 3:0  | <p>Enable the Alert feature when thresholds are surpassed as follows:</p> <ul style="list-style-type: none"> <li>Bit 0 = RH Low alert enable</li> <li>Bit 1 = RH High alert enable</li> <li>Bit 2 = Temperature Low alert enable</li> <li>Bit 3 = Temperature High alert enable</li> </ul> <p>Setting a bit to 0b1 means this specific alert condition is enabled and setting a bit to 0b0 means this specific alert condition is disabled.</p>   |               |   |   |                          |   |   |   |               |   |   |   |   |   |  |   |   |   |   |   |   |   |   |   |   |   |   |   |   |   |   |   |     |  |  |  |  |  |  |                          |  |  |  |  |  |  |  |  |  |  |  |  |  |                         |  |  |  |  |  |  |
| Trigger Threshold for Temperature High Alert                        | 0x08, 0x07             | 13:0 | <p>Registers 0x08, 0x07 set the threshold for when the “Temperature High” alert is triggered. When the measured temperature goes above the value in this register, the Alert pin will be triggered.</p> <p>The temperature used for the threshold is composed of 14 bits as follows:</p> <table border="1" style="margin-left: auto; margin-right: auto;"> <tr> <th colspan="7">Register 0x08</th> <th colspan="7">Register 0x07</th> </tr> <tr> <td>0</td><td>0</td><td>0</td><td>0</td><td>0</td><td>0</td><td>1</td> <td>0</td><td>1</td><td>1</td><td>0</td><td>0</td><td>0</td><td>0</td><td>0</td><td>0</td><td>0</td> </tr> <tr> <td colspan="7">0's</td> <td colspan="7">Trigger Threshold [13:8]</td> </tr> <tr> <td colspan="7"></td> <td colspan="7">Trigger Threshold [7:0]</td> </tr> </table> <p>This 14-bit value is converted into a temperature threshold using the same conversion equation shown in section 4.4.3.</p>                       | Register 0x08 |   |   |                          |   |   |   | Register 0x07 |   |   |   |   |   |  | 0 | 0 | 0 | 0 | 0 | 0 | 1 | 0 | 1 | 1 | 0 | 0 | 0 | 0 | 0 | 0 | 0 | 0's |  |  |  |  |  |  | Trigger Threshold [13:8] |  |  |  |  |  |  |  |  |  |  |  |  |  | Trigger Threshold [7:0] |  |  |  |  |  |  |
| Register 0x08   |                        |      |   |               |   |   | Register 0x07            |   |   |   |               |   |   |   |   |   |  |   |   |   |   |   |   |   |   |   |   |   |   |   |   |   |   |   |     |  |  |  |  |  |  |                          |  |  |  |  |  |  |  |  |  |  |  |  |  |                         |  |  |  |  |  |  |
| 0   | 0                      | 0    | 0   | 0             | 0 | 1 | 0                        | 1 | 1 | 0 | 0             | 0 | 0 | 0 | 0 | 0 |  |   |   |   |   |   |   |   |   |   |   |   |   |   |   |   |   |   |     |  |  |  |  |  |  |                          |  |  |  |  |  |  |  |  |  |  |  |  |  |                         |  |  |  |  |  |  |
| 0's   |                        |      |   |               |   |   | Trigger Threshold [13:8] |   |   |   |               |   |   |   |   |   |  |   |   |   |   |   |   |   |   |   |   |   |   |   |   |   |   |   |     |  |  |  |  |  |  |                          |  |  |  |  |  |  |  |  |  |  |  |  |  |                         |  |  |  |  |  |  |
|   |                        |      |   |               |   |   | Trigger Threshold [7:0]  |   |   |   |               |   |   |   |   |   |  |   |   |   |   |   |   |   |   |   |   |   |   |   |   |   |   |   |     |  |  |  |  |  |  |                          |  |  |  |  |  |  |  |  |  |  |  |  |  |                         |  |  |  |  |  |  |
| Reset Threshold for Temperature High Alert                          | 0x06, 0x05             | 13:0 | <p>Registers 0x06, 0x05 set the threshold for when the “Temperature High” alert condition is reset. After the alert is triggered, it will only be reset after the measured temperature goes below the value in this register.</p> <p>The temperature used for the threshold is composed of 14 bits as follows:</p> <table border="1" style="margin-left: auto; margin-right: auto;"> <tr> <th colspan="7">Register 0x06</th> <th colspan="7">Register 0x05</th> </tr> <tr> <td>0</td><td>0</td><td>0</td><td>0</td><td>0</td><td>0</td><td>1</td> <td>0</td><td>1</td><td>1</td><td>0</td><td>0</td><td>0</td><td>0</td><td>0</td><td>0</td><td>0</td> </tr> <tr> <td colspan="7">0's</td> <td colspan="7">Reset Threshold [13:8]</td> </tr> <tr> <td colspan="7"></td> <td colspan="7">Reset Threshold [7:0]</td> </tr> </table> <p>This 14-bit value is converted into a temperature threshold using the same conversion equation shown in section 4.4.3.</p> | Register 0x06 |   |   |                          |   |   |   | Register 0x05 |   |   |   |   |   |  | 0 | 0 | 0 | 0 | 0 | 0 | 1 | 0 | 1 | 1 | 0 | 0 | 0 | 0 | 0 | 0 | 0 | 0's |  |  |  |  |  |  | Reset Threshold [13:8]   |  |  |  |  |  |  |  |  |  |  |  |  |  | Reset Threshold [7:0]   |  |  |  |  |  |  |
| Register 0x06   |                        |      |   |               |   |   | Register 0x05            |   |   |   |               |   |   |   |   |   |  |   |   |   |   |   |   |   |   |   |   |   |   |   |   |   |   |   |     |  |  |  |  |  |  |                          |  |  |  |  |  |  |  |  |  |  |  |  |  |                         |  |  |  |  |  |  |
| 0   | 0                      | 0    | 0   | 0             | 0 | 1 | 0                        | 1 | 1 | 0 | 0             | 0 | 0 | 0 | 0 | 0 |  |   |   |   |   |   |   |   |   |   |   |   |   |   |   |   |   |   |     |  |  |  |  |  |  |                          |  |  |  |  |  |  |  |  |  |  |  |  |  |                         |  |  |  |  |  |  |
| 0's   |                        |      |   |               |   |   | Reset Threshold [13:8]   |   |   |   |               |   |   |   |   |   |  |   |   |   |   |   |   |   |   |   |   |   |   |   |   |   |   |   |     |  |  |  |  |  |  |                          |  |  |  |  |  |  |  |  |  |  |  |  |  |                         |  |  |  |  |  |  |
|   |                        |      |   |               |   |   | Reset Threshold [7:0]    |   |   |   |               |   |   |   |   |   |  |   |   |   |   |   |   |   |   |   |   |   |   |   |   |   |   |   |     |  |  |  |  |  |  |                          |  |  |  |  |  |  |  |  |  |  |  |  |  |                         |  |  |  |  |  |  |
| Trigger Threshold for Temperature Low Alert                         | 0x0A, 0x09             | 13:0 | <p>Registers 0x0A, 0x09 set the threshold for when the “Temperature Low” alert is triggered. When the measured temperature goes below the value in this register, the Alert pin will be triggered.</p> <p>The temperature used for the threshold is composed of 14 bits as follows:</p> <table border="1" style="margin-left: auto; margin-right: auto;"> <tr> <th colspan="7">Register 0x0A</th> <th colspan="7">Register 0x09</th> </tr> <tr> <td>0</td><td>0</td><td>0</td><td>0</td><td>0</td><td>0</td><td>1</td> <td>0</td><td>1</td><td>1</td><td>0</td><td>0</td><td>0</td><td>0</td><td>0</td><td>0</td><td>0</td> </tr> <tr> <td colspan="7">0's</td> <td colspan="7">Trigger Threshold [13:8]</td> </tr> <tr> <td colspan="7"></td> <td colspan="7">Trigger Threshold [7:0]</td> </tr> </table> <p>This 14-bit value is converted into a temperature threshold using the same conversion equation shown in section 4.4.3.</p>                        | Register 0x0A |   |   |                          |   |   |   | Register 0x09 |   |   |   |   |   |  | 0 | 0 | 0 | 0 | 0 | 0 | 1 | 0 | 1 | 1 | 0 | 0 | 0 | 0 | 0 | 0 | 0 | 0's |  |  |  |  |  |  | Trigger Threshold [13:8] |  |  |  |  |  |  |  |  |  |  |  |  |  | Trigger Threshold [7:0] |  |  |  |  |  |  |
| Register 0x0A   |                        |      |   |               |   |   | Register 0x09            |   |   |   |               |   |   |   |   |   |  |   |   |   |   |   |   |   |   |   |   |   |   |   |   |   |   |   |     |  |  |  |  |  |  |                          |  |  |  |  |  |  |  |  |  |  |  |  |  |                         |  |  |  |  |  |  |
| 0   | 0                      | 0    | 0   | 0             | 0 | 1 | 0                        | 1 | 1 | 0 | 0             | 0 | 0 | 0 | 0 | 0 |  |   |   |   |   |   |   |   |   |   |   |   |   |   |   |   |   |   |     |  |  |  |  |  |  |                          |  |  |  |  |  |  |  |  |  |  |  |  |  |                         |  |  |  |  |  |  |
| 0's   |                        |      |   |               |   |   | Trigger Threshold [13:8] |   |   |   |               |   |   |   |   |   |  |   |   |   |   |   |   |   |   |   |   |   |   |   |   |   |   |   |     |  |  |  |  |  |  |                          |  |  |  |  |  |  |  |  |  |  |  |  |  |                         |  |  |  |  |  |  |
|   |                        |      |   |               |   |   | Trigger Threshold [7:0]  |   |   |   |               |   |   |   |   |   |  |   |   |   |   |   |   |   |   |   |   |   |   |   |   |   |   |   |     |  |  |  |  |  |  |                          |  |  |  |  |  |  |  |  |  |  |  |  |  |                         |  |  |  |  |  |  |
| Reset Threshold for Temperature Low Alert                           | 0x0C, 0x0B             | 13:0 | <p>Registers 0x0C, 0x0B set the threshold for when the “Temperature Low” alert condition is reset. After the alert is triggered, it will only be reset after the measured temperature goes above the value in this register.</p> <p>The temperature used for the threshold is composed of 14 bits as follows:</p> <table border="1" style="margin-left: auto; margin-right: auto;"> <tr> <th colspan="7">Register 0x0C</th> <th colspan="7">Register 0x0B</th> </tr> <tr> <td>0</td><td>0</td><td>0</td><td>0</td><td>0</td><td>0</td><td>1</td> <td>0</td><td>1</td><td>1</td><td>0</td><td>0</td><td>0</td><td>0</td><td>0</td><td>0</td><td>0</td> </tr> <tr> <td colspan="7">0's</td> <td colspan="7">Reset Threshold [13:8]</td> </tr> <tr> <td colspan="7"></td> <td colspan="7">Reset Threshold [7:0]</td> </tr> </table> <p>This 14-bit value is converted into a temperature threshold using the same conversion equation shown in section 4.4.3.</p>  | Register 0x0C |   |   |                          |   |   |   | Register 0x0B |   |   |   |   |   |  | 0 | 0 | 0 | 0 | 0 | 0 | 1 | 0 | 1 | 1 | 0 | 0 | 0 | 0 | 0 | 0 | 0 | 0's |  |  |  |  |  |  | Reset Threshold [13:8]   |  |  |  |  |  |  |  |  |  |  |  |  |  | Reset Threshold [7:0]   |  |  |  |  |  |  |
| Register 0x0C   |                        |      |   |               |   |   | Register 0x0B            |   |   |   |               |   |   |   |   |   |  |   |   |   |   |   |   |   |   |   |   |   |   |   |   |   |   |   |     |  |  |  |  |  |  |                          |  |  |  |  |  |  |  |  |  |  |  |  |  |                         |  |  |  |  |  |  |
| 0   | 0                      | 0    | 0   | 0             | 0 | 1 | 0                        | 1 | 1 | 0 | 0             | 0 | 0 | 0 | 0 | 0 |  |   |   |   |   |   |   |   |   |   |   |   |   |   |   |   |   |   |     |  |  |  |  |  |  |                          |  |  |  |  |  |  |  |  |  |  |  |  |  |                         |  |  |  |  |  |  |
| 0's   |                        |      |   |               |   |   | Reset Threshold [13:8]   |   |   |   |               |   |   |   |   |   |  |   |   |   |   |   |   |   |   |   |   |   |   |   |   |   |   |   |     |  |  |  |  |  |  |                          |  |  |  |  |  |  |  |  |  |  |  |  |  |                         |  |  |  |  |  |  |
|   |                        |      |   |               |   |   | Reset Threshold [7:0]    |   |   |   |               |   |   |   |   |   |  |   |   |   |   |   |   |   |   |   |   |   |   |   |   |   |   |   |     |  |  |  |  |  |  |                          |  |  |  |  |  |  |  |  |  |  |  |  |  |                         |  |  |  |  |  |  |

| Setting  | Register Address (HEX) | Bits | Description  |               |   |   |                          |   |   |   |               |   |   |                         |   |   |  |   |   |   |   |   |   |   |   |   |   |   |   |   |   |   |   |   |     |  |  |  |  |  |  |                          |  |  |  |  |  |  |                         |  |  |  |  |  |  |
|--|------------------------|------|--|---------------|---|---|--------------------------|---|---|---|---------------|---|---|-------------------------|---|---|--|---|---|---|---|---|---|---|---|---|---|---|---|---|---|---|---|---|-----|--|--|--|--|--|--|--------------------------|--|--|--|--|--|--|-------------------------|--|--|--|--|--|--|
| Trigger Threshold for Relative Humidity High Alert | 0x10, 0x0F             | 13:0 | <p>Registers 0x10, 0x0F set the threshold for when the “RH High” alert is triggered. When the measured RH goes above the value in this register, the Alert pin will be triggered.</p> <p>The humidity used for the threshold is composed of 14 bits as follows:</p> <table border="1"> <tr> <th colspan="7">Register 0x10</th> <th colspan="7">Register 0x0F</th> </tr> <tr> <td>0</td><td>0</td><td>0</td><td>0</td><td>0</td><td>1</td><td>0</td><td>1</td><td>1</td><td>0</td><td>0</td><td>0</td><td>0</td><td>0</td><td>0</td><td>0</td><td>0</td> </tr> <tr> <td colspan="7">0's</td> <td colspan="7">Trigger Threshold [13:8]</td> <td colspan="7">Trigger Threshold [7:0]</td> </tr> </table> <p>This 14-bit value is converted into a humidity threshold using the same conversion equation shown in section 4.4.3.</p>                       | Register 0x10 |   |   |                          |   |   |   | Register 0x0F |   |   |                         |   |   |  | 0 | 0 | 0 | 0 | 0 | 1 | 0 | 1 | 1 | 0 | 0 | 0 | 0 | 0 | 0 | 0 | 0 | 0's |  |  |  |  |  |  | Trigger Threshold [13:8] |  |  |  |  |  |  | Trigger Threshold [7:0] |  |  |  |  |  |  |
| Register 0x10                                      |                        |      |  |               |   |   | Register 0x0F            |   |   |   |               |   |   |                         |   |   |  |   |   |   |   |   |   |   |   |   |   |   |   |   |   |   |   |   |     |  |  |  |  |  |  |                          |  |  |  |  |  |  |                         |  |  |  |  |  |  |
| 0  | 0                      | 0    | 0  | 0             | 1 | 0 | 1                        | 1 | 0 | 0 | 0             | 0 | 0 | 0                       | 0 | 0 |  |   |   |   |   |   |   |   |   |   |   |   |   |   |   |   |   |   |     |  |  |  |  |  |  |                          |  |  |  |  |  |  |                         |  |  |  |  |  |  |
| 0's  |                        |      |  |               |   |   | Trigger Threshold [13:8] |   |   |   |               |   |   | Trigger Threshold [7:0] |   |   |  |   |   |   |   |   |   |   |   |   |   |   |   |   |   |   |   |   |     |  |  |  |  |  |  |                          |  |  |  |  |  |  |                         |  |  |  |  |  |  |
| Reset Threshold for Relative Humidity High Alert   | 0x0E, 0x0D             | 13:0 | <p>Registers 0x0E, 0x0D set the threshold for when the “RH High” alert condition is reset. After the alert is triggered, it will only be reset after the measured RH goes below the value in this register.</p> <p>The humidity used for the threshold is composed of 14 bits as follows:</p> <table border="1"> <tr> <th colspan="7">Register 0x0E</th> <th colspan="7">Register 0x0D</th> </tr> <tr> <td>0</td><td>0</td><td>0</td><td>0</td><td>0</td><td>1</td><td>0</td><td>1</td><td>1</td><td>0</td><td>0</td><td>0</td><td>0</td><td>0</td><td>0</td><td>0</td><td>0</td> </tr> <tr> <td colspan="7">0's</td> <td colspan="7">Reset Threshold [13:8]</td> <td colspan="7">Reset Threshold [7:0]</td> </tr> </table> <p>This 14-bit value is converted into a humidity threshold using the same conversion equation shown in section 4.4.3.</p> | Register 0x0E |   |   |                          |   |   |   | Register 0x0D |   |   |                         |   |   |  | 0 | 0 | 0 | 0 | 0 | 1 | 0 | 1 | 1 | 0 | 0 | 0 | 0 | 0 | 0 | 0 | 0 | 0's |  |  |  |  |  |  | Reset Threshold [13:8]   |  |  |  |  |  |  | Reset Threshold [7:0]   |  |  |  |  |  |  |
| Register 0x0E                                      |                        |      |  |               |   |   | Register 0x0D            |   |   |   |               |   |   |                         |   |   |  |   |   |   |   |   |   |   |   |   |   |   |   |   |   |   |   |   |     |  |  |  |  |  |  |                          |  |  |  |  |  |  |                         |  |  |  |  |  |  |
| 0  | 0                      | 0    | 0  | 0             | 1 | 0 | 1                        | 1 | 0 | 0 | 0             | 0 | 0 | 0                       | 0 | 0 |  |   |   |   |   |   |   |   |   |   |   |   |   |   |   |   |   |   |     |  |  |  |  |  |  |                          |  |  |  |  |  |  |                         |  |  |  |  |  |  |
| 0's  |                        |      |  |               |   |   | Reset Threshold [13:8]   |   |   |   |               |   |   | Reset Threshold [7:0]   |   |   |  |   |   |   |   |   |   |   |   |   |   |   |   |   |   |   |   |   |     |  |  |  |  |  |  |                          |  |  |  |  |  |  |                         |  |  |  |  |  |  |
| Trigger Threshold for Relative Humidity Low Alert  | 0x12, 0x11             | 13:0 | <p>Registers 0x12, 0x11 set the threshold for when the “RH Low” alert is triggered. When the measured RH goes below the value in this register, the Alert pin will be triggered.</p> <p>The humidity used for the threshold is composed of 14 bits as follows:</p> <table border="1"> <tr> <th colspan="7">Register 0x12</th> <th colspan="7">Register 0x11</th> </tr> <tr> <td>0</td><td>0</td><td>0</td><td>0</td><td>0</td><td>1</td><td>0</td><td>1</td><td>1</td><td>0</td><td>0</td><td>0</td><td>0</td><td>0</td><td>0</td><td>0</td><td>0</td> </tr> <tr> <td colspan="7">0's</td> <td colspan="7">Trigger Threshold [13:8]</td> <td colspan="7">Trigger Threshold [7:0]</td> </tr> </table> <p>This 14-bit value is converted into a humidity threshold using the same conversion equation shown in section 4.4.3.</p>                        | Register 0x12 |   |   |                          |   |   |   | Register 0x11 |   |   |                         |   |   |  | 0 | 0 | 0 | 0 | 0 | 1 | 0 | 1 | 1 | 0 | 0 | 0 | 0 | 0 | 0 | 0 | 0 | 0's |  |  |  |  |  |  | Trigger Threshold [13:8] |  |  |  |  |  |  | Trigger Threshold [7:0] |  |  |  |  |  |  |
| Register 0x12                                      |                        |      |  |               |   |   | Register 0x11            |   |   |   |               |   |   |                         |   |   |  |   |   |   |   |   |   |   |   |   |   |   |   |   |   |   |   |   |     |  |  |  |  |  |  |                          |  |  |  |  |  |  |                         |  |  |  |  |  |  |
| 0  | 0                      | 0    | 0  | 0             | 1 | 0 | 1                        | 1 | 0 | 0 | 0             | 0 | 0 | 0                       | 0 | 0 |  |   |   |   |   |   |   |   |   |   |   |   |   |   |   |   |   |   |     |  |  |  |  |  |  |                          |  |  |  |  |  |  |                         |  |  |  |  |  |  |
| 0's  |                        |      |  |               |   |   | Trigger Threshold [13:8] |   |   |   |               |   |   | Trigger Threshold [7:0] |   |   |  |   |   |   |   |   |   |   |   |   |   |   |   |   |   |   |   |   |     |  |  |  |  |  |  |                          |  |  |  |  |  |  |                         |  |  |  |  |  |  |
| Reset Threshold for Relative Humidity Low Alert    | 0x14, 0x13             | 13:0 | <p>Registers 0x14, 0x13 sets the threshold for when the “RH Low” alert condition is reset. After the alert is triggered, it will only be reset after the measured RH goes above the value in this register.</p> <p>The humidity used for the threshold is composed of 14 bits as follows:</p> <table border="1"> <tr> <th colspan="7">Register 0x14</th> <th colspan="7">Register 0x13</th> </tr> <tr> <td>0</td><td>0</td><td>0</td><td>0</td><td>0</td><td>1</td><td>0</td><td>1</td><td>1</td><td>0</td><td>0</td><td>0</td><td>0</td><td>0</td><td>0</td><td>0</td><td>0</td> </tr> <tr> <td colspan="7">0's</td> <td colspan="7">Reset Threshold [13:8]</td> <td colspan="7">Reset Threshold [7:0]</td> </tr> </table> <p>This 14-bit value is converted into a humidity threshold using the same conversion equation shown in section 4.4.3.</p> | Register 0x14 |   |   |                          |   |   |   | Register 0x13 |   |   |                         |   |   |  | 0 | 0 | 0 | 0 | 0 | 1 | 0 | 1 | 1 | 0 | 0 | 0 | 0 | 0 | 0 | 0 | 0 | 0's |  |  |  |  |  |  | Reset Threshold [13:8]   |  |  |  |  |  |  | Reset Threshold [7:0]   |  |  |  |  |  |  |
| Register 0x14                                      |                        |      |  |               |   |   | Register 0x13            |   |   |   |               |   |   |                         |   |   |  |   |   |   |   |   |   |   |   |   |   |   |   |   |   |   |   |   |     |  |  |  |  |  |  |                          |  |  |  |  |  |  |                         |  |  |  |  |  |  |
| 0  | 0                      | 0    | 0  | 0             | 1 | 0 | 1                        | 1 | 0 | 0 | 0             | 0 | 0 | 0                       | 0 | 0 |  |   |   |   |   |   |   |   |   |   |   |   |   |   |   |   |   |   |     |  |  |  |  |  |  |                          |  |  |  |  |  |  |                         |  |  |  |  |  |  |
| 0's  |                        |      |  |               |   |   | Reset Threshold [13:8]   |   |   |   |               |   |   | Reset Threshold [7:0]   |   |   |  |   |   |   |   |   |   |   |   |   |   |   |   |   |   |   |   |   |     |  |  |  |  |  |  |                          |  |  |  |  |  |  |                         |  |  |  |  |  |  |

### 4.9 Reading the Sensor ID Number

The sensor ID is a 32-bit number that can be used to identify a specific device. Each sensor has a unique ID that can be used for traceability. The sequence to read the sensor ID is as follows:

1. Wake up the HS40xx series sensor from sleep mode by sending its I<sup>2</sup>C address with a write bit and initiate a Read Sensor ID command by sending the command 0xD7.
2. Change the direction of communication by sending the HS40xx I<sup>2</sup>C address and a read bit. The SCL line is held low by the sensor while it retrieves the ID from internal memory to prevent data corruption. The sensor takes approximately 10µs to retrieve the ID from internal memory.

- Once the request is completed by the HS40xx, the SCL line is released and the chip waits for the SCL clock signal to send the results. The sensor will then transmit the 4-byte sensor ID on the bus for the master to capture, MSB first.

The command sequence to read the sensor ID is displayed in Figure 20.

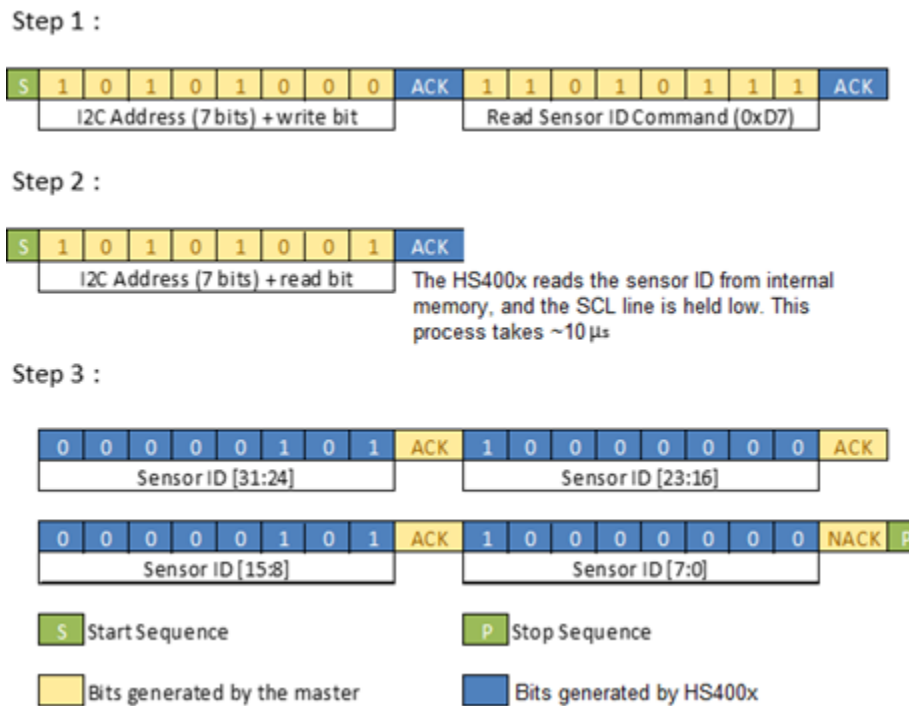

Figure 20. Read Sensor ID Command Sequence

### 4.10 Resetting the Sensor

With the command 0xFE, it is possible to soft reset the HS40xx. The reset will affect all writeable registers and sets them back to the default value. To use this command, ensure that the following conditions are met:

- If the user initiates a measurement, they must read the measurement data before issuing the soft reset command.
- If the user has the HS40xx in Periodic Measurement Mode, they must escape the “Periodic Measurement Mode” before issuing the soft reset command. This can be achieved by sending the “Stop Periodic Measurement” command.

To reset the sensor, use the following sequence:

- Wake up the HS40xx series sensor from sleep mode by sending its I<sup>2</sup>C address with a write bit.
- Send the soft reset command 0xFE.

After sending the reset command, wait for at least 500ms before starting to communicate with the HS40xx. The sensor will behave like it was just powered on.

## 5. Conditioning

After soldering or prolonged storage outside the nominal storage conditions, a conditioning routine must be applied to ensure high sensor accuracy. Not following this routine will result in a slowly disappearing offset in the relative humidity readings. When a relative humidity sensor is exposed to the high heat associated with the soldering process, the sensor element tends to dry out. To avoid an offset in the relative humidity readings, the sensor element must be rehydrated after the soldering process.

Recommended rehydration process:

- A relative humidity of 75% RH at room temperature for at least 12 hours, or
- A relative humidity of 40% to 50% RH at room temperature for 3 to 5 days

To avoid relative humidity reading offset after prolonged storage outside the *recommended storage conditions*, use the following procedure to recondition the humidity sensor.

1. Bake at a temperature of 100°C with a humidity < 10% RH for 10 to 12 hours.
2. Rehydrate the sensor at a humidity of 75% RH and a temperature between 20°C to 30°C for 12 to 14 hours.

## 6. Application Circuit

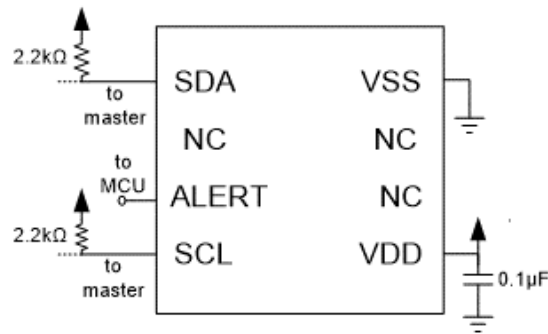

Figure 21. HS40xx Application Circuit – Top View

## 7. Soldering Information

This section discusses soldering considerations for the HS40xx.

Standard reflow ovens can be used to solder the HS40xx series sensor to the PCB. The peak temperature ( $T_p$ ) for use with the JEDEC J-STD-020D standard soldering profile is 260°C. For manual soldering, the contact time must be limited to 5 seconds at up to 350°C. In either case, if solder paste is used, it is recommended to use “no-clean” solder paste to avoid the need to wash the PCB.

When a relative humidity sensor is exposed to the high heat associated with the soldering process, the sensor element tends to dry out. To avoid an offset in the relative humidity readings, the sensor element must be rehydrated after the soldering process. Care must also be taken when selecting the temperatures and durations involved in the soldering process to avoid irreversibly damaging the sensor element.

The recommended soldering profile for a lead-free (RoHS-compliant) process is shown below.

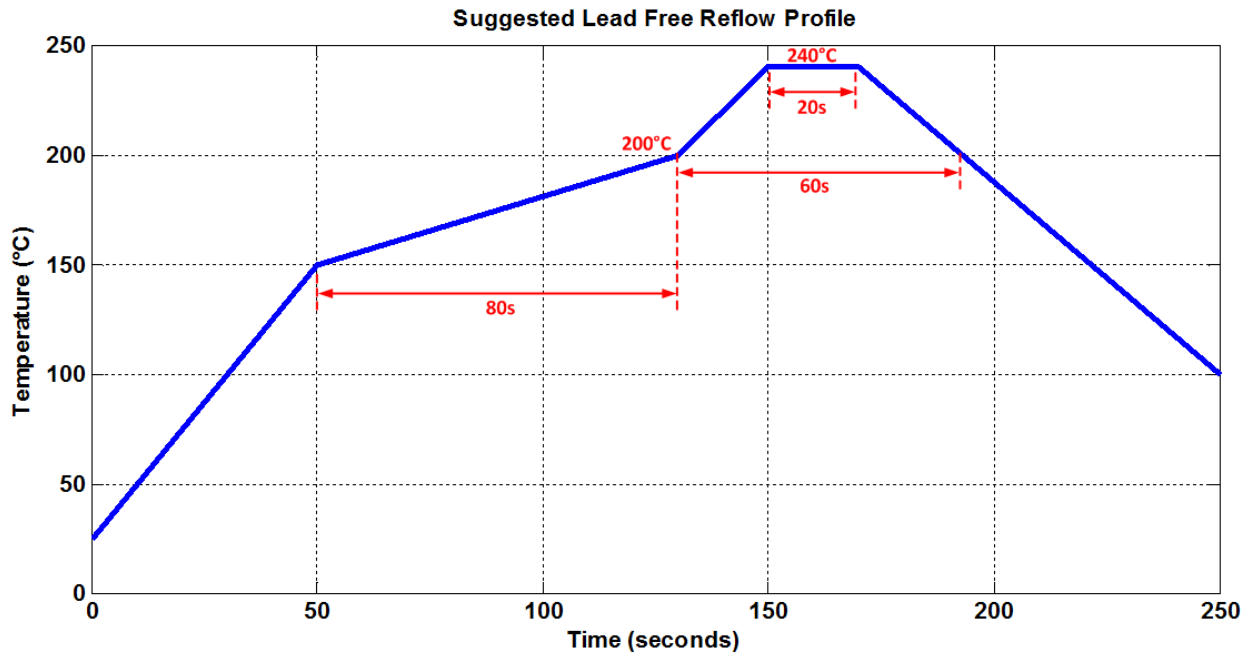

Figure 22. Recommended Soldering Profile

*Important:* Ensure this temperature profile is measured at the sensor itself. Measuring the profile at a larger component with a higher thermal mass means the temperature at the small sensor will be higher than expected. For manual soldering, the contact time must be limited to **5 seconds** with a maximum iron temperature of **350°C**. In either case, a board wash after soldering is **not** recommended. Therefore, if a solder paste is used, it is strongly recommended that a “no-clean” solder paste is used to avoid the need to wash the PCB. After soldering, the recommended rehydration process in section 5 should be performed. Otherwise, there may be an initial offset in the relative humidity readings, which will slowly disappear as the sensor get exposed to ambient conditions.



## 8. PCB Layout Guidelines

When designing the PCB, undesired heat transfer paths to the HS40xx series must be minimized. Excessive heat from other components on the PCB will result in inaccurate temperature and relative humidity measurements. As such, **solid metal planes for power supplies should be avoided in the vicinity of the sensor** since these will act as thermal conductors. To further reduce the heat transfer from other components on the board, openings can be milled into the PCB as shown in Figure 23.

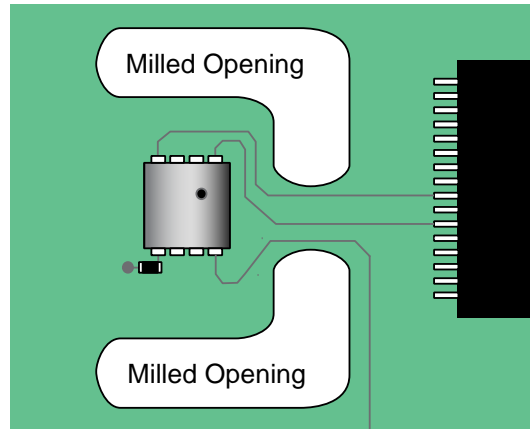

Figure 23. Milled PCB Openings for Thermal Isolation

## 9. Storage and Handling

**Recommendation:** Once the sensors are removed from their original packaging, store them in metal-in antistatic bags.

Avoid using polyethylene antistatic bags as they may affect sensor accuracy.

The nominal storage conditions are 10°C to 50°C and humidity levels within 20% to 60%RH. If stored outside of these conditions for extended periods of time, the sensor readings may exhibit an offset. The sensor can be reconditioned and brought back to its calibration state by applying the procedure described in section 5.

## 10. Quality and Reliability

The HS40xx series is available as a qualified product for consumer and industrial market applications. All data specified parameters are guaranteed if not stated otherwise.

## 11. Package Outline Drawings

The package outline drawings are located at the end of this document and are accessible from the Renesas website. The package information is the most current data available and is subject to change without revision of this document.

## 12. Marking Diagram

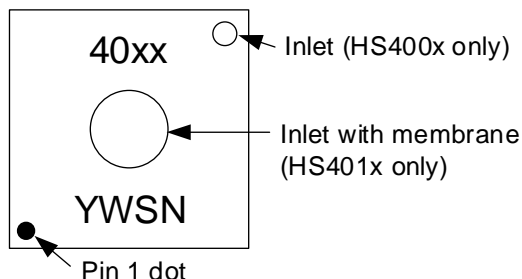

- Line 1: Sensor type (for example, 4011)
- Line 2:
  - First character: Year (for example, 3 = 2023)
  - Second character: Week code (for example, X = 31)
  - Third and fourth character: Test Release Sequence Number

## 13. Ordering Information

| Part Number | Package Description   | Carrier Type | Temperature Range |
|-------------|---|--------------|-------------------|
| HS4001      | Digital Relative Humidity and Temperature Sensor, $\pm 1.5\%$ RH (typical), 2.50 × 2.50 × 0.90 mm, <a href="#">8-LGA</a>                | Reel         | -40°C to +125°C   |
| HS4003      | Digital Relative Humidity and Temperature Sensor, $\pm 2.5\%$ RH (typical), 2.50 × 2.50 × 0.90 mm, <a href="#">8-LGA</a>                | Reel         | -40°C to +125°C   |
| HS4011      | Digital Relative Humidity and Temperature Sensor, with membrane. $\pm 1.5\%$ RH (typical), 2.50 × 2.50 × 0.90 mm, <a href="#">8-LGA</a> | Reel         | -40°C to +125°C   |
| HS4013      | Digital Relative Humidity and Temperature Sensor, with membrane. $\pm 2.5\%$ RH (typical), 2.50 × 2.50 × 0.90 mm, <a href="#">8-LGA</a> | Reel         | -40°C to +125°C   |

## 14. Revision History

| Revision | Date         | Description  |
|----------|--------------|--|
| 1.01     | Nov 3, 2023  | <ul style="list-style-type: none"> <li>▪ Added Functional Diagram</li> <li>▪ Added Conditioning section</li> <li>▪ Added Resetting the Sensor section</li> <li>▪ Updated Pin Assignments and Pin Descriptions</li> <li>▪ Updated performance characteristics</li> <li>▪ Updated Soldering Information and Storage and Handling sections</li> </ul> |
| 1.00     | Aug 11, 2023 | Initial release.   |

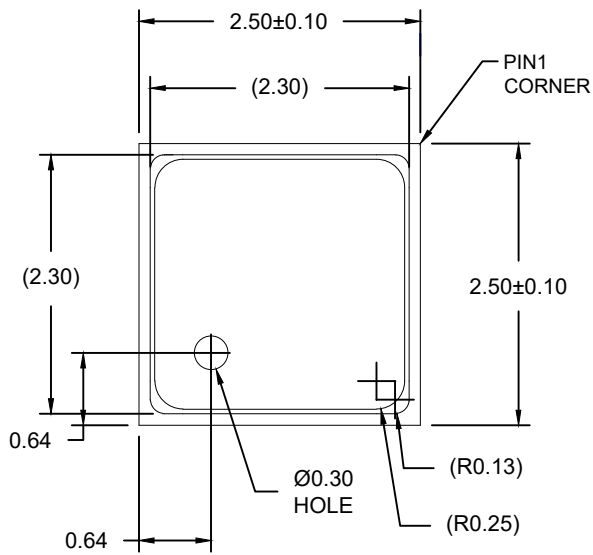

TOP VIEW

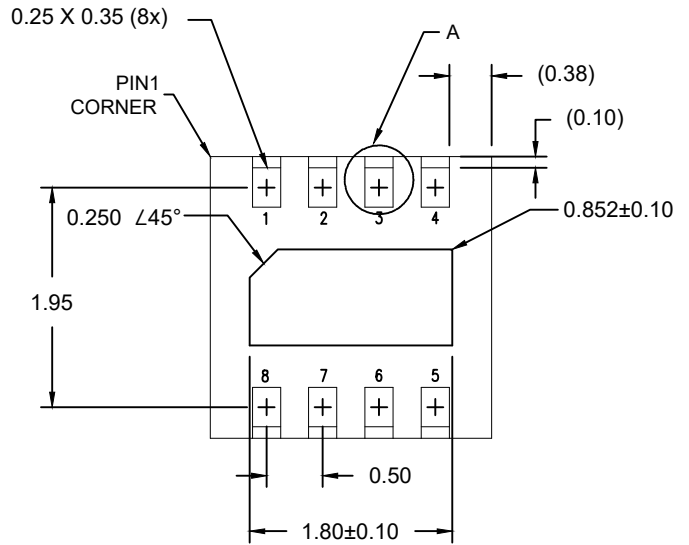

BOTTOM VIEW

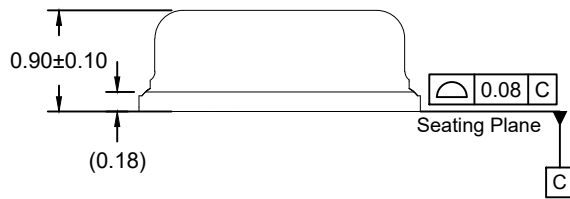

SIDE VIEW

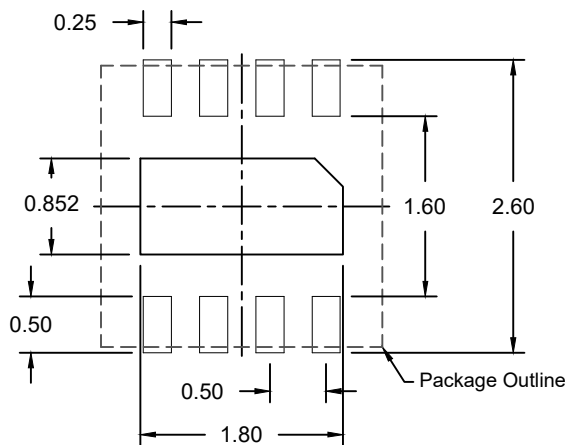
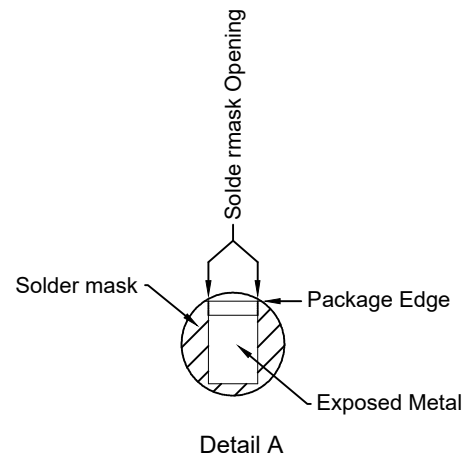

RECOMMENDED LAND PATTERN  
(PCB Top View, NSMD Design)

**NOTES:**

1. JEDEC compatible
2. All dimensions are in mm, angles in degrees.
3. Use  $\pm 0.05$  mm for non-toleranced dimensions.
4. Numbers in ( ) are for reference only.

## IMPORTANT NOTICE AND DISCLAIMER

RENESAS ELECTRONICS CORPORATION AND ITS SUBSIDIARIES (“RENESAS”) PROVIDES TECHNICAL SPECIFICATIONS AND RELIABILITY DATA (INCLUDING DATASHEETS), DESIGN RESOURCES (INCLUDING REFERENCE DESIGNS), APPLICATION OR OTHER DESIGN ADVICE, WEB TOOLS, SAFETY INFORMATION, AND OTHER RESOURCES “AS IS” AND WITH ALL FAULTS, AND DISCLAIMS ALL WARRANTIES, EXPRESS OR IMPLIED, INCLUDING, WITHOUT LIMITATION, ANY IMPLIED WARRANTIES OF MERCHANTABILITY, FITNESS FOR A PARTICULAR PURPOSE, OR NON-INFRINGEMENT OF THIRD-PARTY INTELLECTUAL PROPERTY RIGHTS.

These resources are intended for developers who are designing with Renesas products. You are solely responsible for (1) selecting the appropriate products for your application, (2) designing, validating, and testing your application, and (3) ensuring your application meets applicable standards, and any other safety, security, or other requirements. These resources are subject to change without notice. Renesas grants you permission to use these resources only to develop an application that uses Renesas products. Other reproduction or use of these resources is strictly prohibited. No license is granted to any other Renesas intellectual property or to any third-party intellectual property. Renesas disclaims responsibility for, and you will fully indemnify Renesas and its representatives against, any claims, damages, costs, losses, or liabilities arising from your use of these resources. Renesas' products are provided only subject to Renesas' Terms and Conditions of Sale or other applicable terms agreed to in writing. No use of any Renesas resources expands or otherwise alters any applicable warranties or warranty disclaimers for these products.

(Disclaimer Rev.1.01 Jan 2024)

### Corporate Headquarters

TOYOSU FORESIA, 3-2-24 Toyosu,  
Koto-ku, Tokyo 135-0061, Japan  
[www.renesas.com](http://www.renesas.com)

### Trademarks

Renesas and the Renesas logo are trademarks of Renesas Electronics Corporation. All trademarks and registered trademarks are the property of their respective owners.

### Contact Information

For further information on a product, technology, the most up-to-date version of a document, or your nearest sales office, please visit [www.renesas.com/contact-us/](http://www.renesas.com/contact-us/).