

RapidCharge™ AC/DC Primary-Side Digital ZVS Flyback Controller

1 Description

The iW9801 is a high-performance AC/DC primary-side digital flyback controller with advanced zero-voltage-switching (ZVS) and adaptive multi-mode-control (MMC) working with secondary-side regulation (SSR) for applications requiring high power density and high resolution in output voltage/current setting. The device can support rapid charge applications such as travel adapters (TA) of 25W and above. It operates under multi-mode control (MMC) including PWM, PFM and burst mode with main switch ZVS turn-on at high line voltage to achieve less switching loss and low EMI. It also provides a number of key built-in protection features.

The iW9801 is optimized to work with Dialog's secondary-side controller, the iW70x, for SSR, synchronous rectifier (SR) control and USB PD 3.0 with PPS protocol support. The iW9801/iW70x chipset can achieve tight multi-level constant voltage (CV) and multi-level constant current (CC) regulation in very fine steps for rapid charge applications. With SSR digital compensation, the chipset eliminates the need for external loop compensation components while maintaining stability under all operating conditions.

The iW9801 and iW70x chipset can support USB PD 3.0 with PPS to achieve fast and smooth CV/CC transitions upon request by mobile devices (MD). The iW9801 and iW70x chipset can meet no-load power consumption of less than 20mW for a typical 25W to 45W design when the output USB cable is detached.

Dialog's innovative proprietary technology ensures that power supplies designed with the iW9801 and iW70x chipset can achieve high efficiency, high accuracy voltage/current control and fast dynamic load response.

2 Features

- Supports USB PD travel adapter (TA) applications of 35W and above
- Supports constant-voltage (CV) and constant-current (CC) regulation in fine steps by secondary-side regulation (SSR)
- Dialog's patented adaptive ZVS control enables high efficiency and low EMI
- User configurable ZVS timing to optimize performance for different power devices
- Adaptive multi-mode control (MMC) using PWM/PFM/Burst modes based on input voltage and output voltage/current improves efficiency and eliminates audible noise
- Built-in single-point fault protections against AC line voltage brown-out, output short-circuit, output over-voltage, and optocoupler failure
- Optional user programable internal over-temperature protection (OTP) threshold for various thermal requirement
- < 20mW no load standby power for typical 25W to 45W designs at 230V_{AC} when output USB cable is detached
- AC unplug detection and X-capacitor discharge control
- 10-lead SOIC package

3 Applications

- Rapid-charging AC/DC adapters for smart phones, tablets and other portable devices

RapidCharge™ AC/DC Primary-Side Digital ZVS Flyback Controller

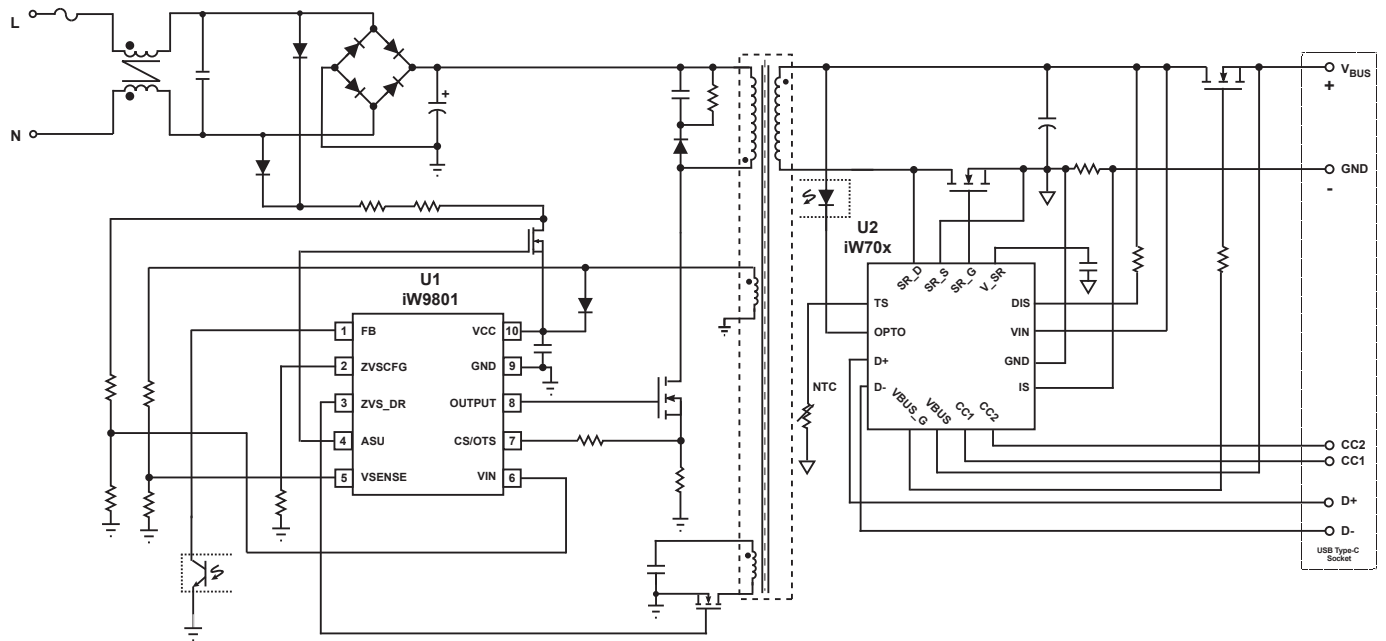

Figure 3.1 : iW9801 Typical Application Circuit with Active Start-up Circuit
 (Using iW70x as Secondary-Side Controller. Achieving Multi-Level CV/CC Regulation)

RapidCharge™ AC/DC Primary-Side Digital ZVS Flyback Controller

4 Pinout Description

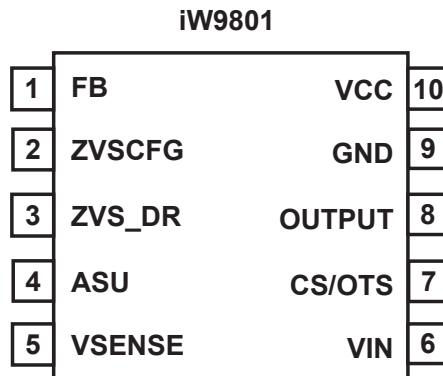

Figure 4.1 : 10-Lead SOIC Package

Pin Number	Pin Name	Type	Pin Description
1	FB	Analog Input	Feedback voltage. Used for determining multi-mode control and cycle-by-cycle peak current control.
2	ZVSCFG	Analog Input	ZVS timing configuraton. Used for fine-tuning of ZVS auxiliary switch turn-on time.
3	ZVS_DR	Analog Output	Gate drive for auxiliary switch for ZVS purpose.
4	ASU	Analog Output	Control Signal. Used for active start-up device (BJT or depletion mode N-FET).
5	VSENSE	Analog Input	Voltage sensing. Used for output voltage sensing and auxiliary winding ringing voltage sensing.
6	VIN	Analog Input	Input AC line voltage detection. Used for AC line voltage detection and AC unplug detection for X-capacitor discharge.
7	CS/OTS	Analog Input	Current sensing. Used for cycle-by-cycle peak-current control and limit. During configuration stage, it can be used to configure certain parameters, such as internal over-temperature protection setting.
8	OUTPUT	Analog Output	Gate drive for main power switch.
9	GND	Ground	Ground.
10	VCC	Power Input	IC power supply.

RapidCharge™ AC/DC Primary-Side Digital ZVS Flyback Controller

5 Absolute Maximum Ratings

Absolute maximum ratings are the parameter values or ranges which can cause permanent damage if exceeded. For maximum safe operating conditions, refer to Electrical Characteristics in Section 6.

Parameter	Symbol	Value	Units
DC supply voltage range	V_{VCC}	-0.3 to 45	V
Continuous DC supply current at VCC pin ($V_{VCC} = 15V$)	I_{VCC}	20	mA
VSENSE input ($I_{VSENSE} \leq 10mA$)		-0.7 to 10	V
FB voltage		-0.3 to 5.0	V
ZVSCFG voltage		-0.3 to 5.5	V
ZVS_DR voltage		-0.3 to 20	V
VIN voltage		-0.3 to 5.0	V
ASU voltage		-0.3 to 45	V
CS/OTS voltage		-0.3 to 5.5	V
OUTPUT voltage		-0.3 to 20	V
Maximum junction temperature	T_{JMAX}	150	°C
Operating junction temperature	T_{JOPT}	-40 to 150	°C
Storage temperature	T_{STO}	-65 to 150	°C
Thermal Resistance Junction-to-Ambient	θ_{JA}	160	°C/W
ESD rating per JEDEC JS-001-2017		$\pm 2,000$	V
Latch-up test per JESD78E		± 100	mA

Notes:

- Note 1. Stresses beyond those listed under Absolute Maximum Ratings may cause permanent damage to the device. These are stress ratings only, so functional operation of the device at these or any other conditions beyond those indicated in the operational sections of the specification are not implied. Exposure to absolute maximum rating conditions for extended periods may affect device reliability.

6 Physical Dimensions

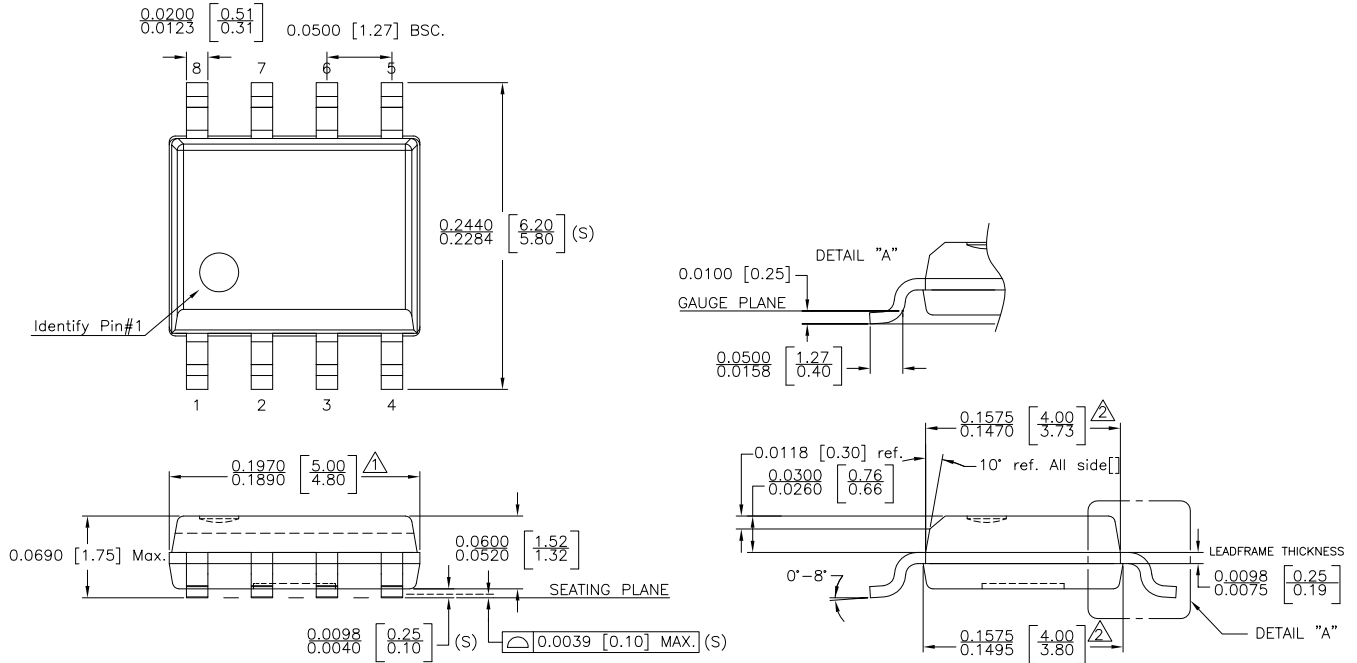

NOTE :

- ⚠ DOES NOT INCLUDE MOLD FLASH, PROTRUSIONS OR GATE BURRS. MOLD FLASH, PROTRUSIONS AND GATE BURRS SHALL NOT EXCEED .006 INCH PER SIDE.
- ⚠ DOES NOT INCLUDE INTER-LEAD FLASH OR PROTRUSIONS. INTER-LEAD FLASH AND PROTRUSIONS SHALL NOT EXCEED .010 INCH PER SIDE.
- 3. THIS PART IS COMPLIANT WITH JEDEC SPECIFICATION MS-012.
- 4. LEAD SPAN/STAND OFF HEIGHT/COPLANARITY ARE CONSIDERED AS SPECIAL CHARACTERISTIC.(S)
- 5. CONTROLLING DIMENSIONS IN INCHES. [mm]

STATUS: RELEASED	SCALE: DO NOT SCALE
TERMINAL FINISH: 100% Sn or NiPdAu (PPF)	
TITLE: 8 SOIC PACKAGE OUTLINE	
REV: D	REVISION NOTE: EJECTOR CHANGED TO DASHED LINE
DATE: 18-JUN-2020	

Figure 6.1 : 10-Lead SOIC Package Outline Drawing

7 Ordering Information

Part no.	Options								Package	Description
	V _{BUS} range	CCM	ZVS	F _{SW(MAX)} at low line	F _{SW(MAX)} at high line	V _{BUS} /V _{SENSE}	X-cap discharge	Internal OTP		
iW9801-00	3.3V to 21V	No	Yes at high line	100kHz	95kHz	1:0.7	Yes	Yes	SOIC-10	Tape & Reel ¹
iW9801-06	3.3V to 21V	Yes	Yes at high line	110kHz	95kHz	1:0.7	Yes	Yes	SOIC-10	Tape & Reel ¹
iW9801-07	3.3V to 21V	No	Yes at high line	140kHz	130kHz	1:0.7	Yes	Yes	SOIC-10	Tape & Reel ¹
iW9801-20	3.3V to 21V	No	Yes at high line	100kHz	95kHz	1:0.7	Yes	No	SOIC-10	Tape & Reel ¹

Note 1: Tape & Reel packing quantity is 2,500/reel. Minimum packing quantity is 2,500.

RapidCharge™ AC/DC Primary-Side Digital ZVS Flyback Controller

8 Top Marking

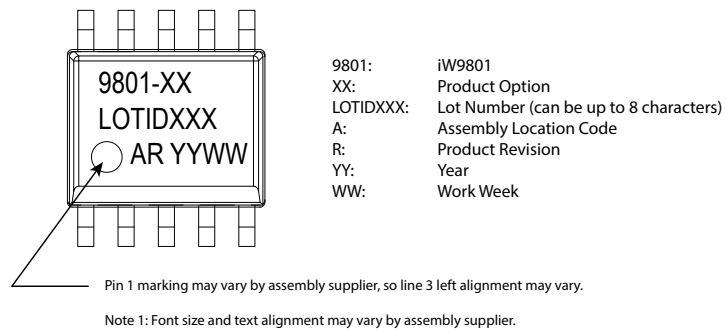

Figure 8.1 : Top Marking for the iW9801 (SOIC-10)

RapidCharge™ AC/DC Primary-Side Digital ZVS Flyback Controller

IMPORTANT NOTICE AND DISCLAIMER

RENESAS ELECTRONICS CORPORATION AND ITS SUBSIDIARIES (“RENESAS”) PROVIDES TECHNICAL SPECIFICATIONS AND RELIABILITY DATA (INCLUDING DATASHEETS), DESIGN RESOURCES (INCLUDING REFERENCE DESIGNS), APPLICATION OR OTHER DESIGN ADVICE, WEB TOOLS, SAFETY INFORMATION, AND OTHER RESOURCES “AS IS” AND WITH ALL FAULTS, AND DISCLAIMS ALL WARRANTIES, EXPRESS OR IMPLIED, INCLUDING, WITHOUT LIMITATION, ANY IMPLIED WARRANTIES OF MERCHANTABILITY, FITNESS FOR A PARTICULAR PURPOSE, OR NON-INFRINGEMENT OF THIRD PARTY INTELLECTUAL PROPERTY RIGHTS.

These resources are intended for developers skilled in the art designing with Renesas products. You are solely responsible for (1) selecting the appropriate products for your application, (2) designing, validating, and testing your application, and (3) ensuring your application meets applicable standards, and any other safety, security, or other requirements. These resources are subject to change without notice. Renesas grants you permission to use these resources only for development of an application that uses Renesas products. Other reproduction or use of these resources is strictly prohibited. No license is granted to any other Renesas intellectual property or to any third party intellectual property. Renesas disclaims responsibility for, and you will fully indemnify Renesas and its representatives against, any claims, damages, costs, losses, or liabilities arising out of your use of these resources. Renesas’ products are provided only subject to Renesas’ Terms and Conditions of Sale or other applicable terms agreed to in writing. No use of any Renesas resources expands or otherwise alters any applicable warranties or warranty disclaimers for these products.

© 2022 Renesas Electronics Corporation. All rights reserved.

RoHS Compliance

Dialog Semiconductor’s suppliers certify that its products are in compliance with the requirements of Directive 2011/65/EU of the European Parliament on the restriction of the use of certain hazardous substances in electrical and electronic equipment. RoHS certificates from our suppliers are available on request.

(Rev.1.0 Mar 2020)

Corporate Headquarters

TOYOSU FORESIA, 3-2-24 Toyosu
Koto-ku, Tokyo 135-0061, Japan
www.renesas.com

Contact Information

For further information on a product, technology, the most up-to-date version of a document, or your nearest sales office, please visit:
www.renesas.com/contact/

Trademarks

Renesas and the Renesas logo are trademarks of Renesas Electronics Corporation. All trademarks and registered trademarks are the property of their respective owners.