

PAGE 1/1	ISSUE 06/13/13	SERIES F-SMA	PART NUMBER F707040000
----------	----------------	--------------	------------------------

**F-SMA CRIMPING STRAIGHT CONNECTOR FOR MULTIMODE 1000µm HCS FIBER**

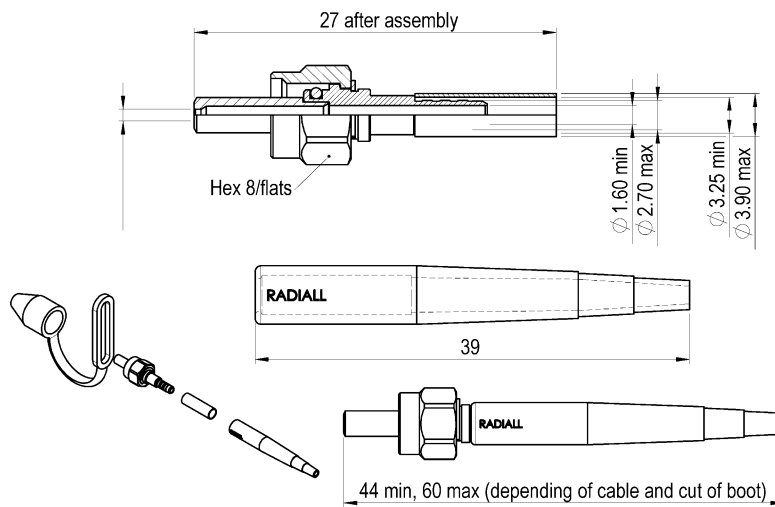

Dimensions: mm [inches]

**GENERAL**

**Type:** IEC 874-2 type FSMA5, connector  
Metalic ferrule  
Screw thread coupling device

**Fiber:** HCS 1010 T

**Cable size & type:** Tight structure cable with aramid members from Ø1.6mm to Ø2.6mm

**Installation:** See assembly procedures 503 08 530 and F 707 PC 08

**CHARACTERISTICS** (Dependent on cable or fiber construction)

**Optical:** Typical insertion loss ( $\lambda=850\text{nm}$ ): 1,5dB

**Mechanical:**

- Mating life : Up to 250 matings
- Fiber retention : 5N
- Cable retention : 100N
- Coupling torque : 40 to 45 N.cm
- Coupling retention : 270N
- Vibration : 10 – 2000 Hz, 20g

**Environmental:** Climatic category : 55/85/10 (IEC 874-1)