

### COAXIAL SPnT up to 40 GHz – RAMSES Concept

# R57

#### Models

- 3 : Without 50 Ω termination
- 4 : With 50 Ω termination

#### Connector RF

- 3 : SMA up to 3 GHz
- 4 : SMA up to 18 GHz
- 7 : SMA 2.9 up to 26.5 GHz (4)
- 8 : SMA 2.9 up to 40 GHz (4)
- 9 : DIN 1.6/5.6 up to 1 GHz (4)

#### Type

- 0 : Normally open
- 1 : Normally open + I.C.
- 2 : Latching
- 3 : Latching + I.C.
- 4 : Latching + S. C. O.(1)(4)
- 5 : Latching + S. C. O. + I.C.(1)(4)
- 8 : Latching + S. C. O. +A.R.(1)
- 9 : Latching + S. C. O.+ I.C.+ A.R. (1)

#### Actuator voltage (2)

- 2 : 12 Vdc
- 3 : 28 Vdc

#### Actuator terminal

- 0 : Solder Pins
- 5 : DSUB

#### Options

- 0 : Without option
- 1 : Positive common (2)
- 2 : Compatible TTL driver(1)
- 3 : With suppression diodes
- 4 : With suppression diodes and positive common (2)
- 8 : BCD driver TTLcompatible(1)(3)

#### Number of positions

- 3 : 3 Positions
- 4 : 4 Positions
- 5 : 5 Positions
- 6 : 6 Positions
- 7 : 7 Positions
- 8 : 8 Positions
- 9 : 9 Positions
- 0 : 10 Positions
- 1 : 11 Positions
- 2 : 12 Positions

**I.C.** : Indicator contact.  
**S.C.O.** : Self Cut Off  
**A.R.** : Automatic Reset

**(1)** : These models are already equipped with suppression diodes.  
**(2)** : Standard products are equipped with common minus.  
**(3)** : Latching BCD driver enables also a manual reset through driver code 0000.  
**(4)** : Available only up to 6 positions, and without 50 Ohms termination

- Latching models have a RESET pin which commands the reset of all positions. This command should be used before switching from one position to another. If not, two positions will be set at the same time.

Note: During the RESET operation the current is : Setting current x number of positions.

- Latching models with AUTOMATIC RESET are available; these products have an internal SET/RESET circuit which automatically set the desired position and reset the non-selected positions. This option simplifies the use of latching switches by suppressing the RESET command in switching sequence.

For example: During the AUTOMATIC RESET operation, a 28V, 4 positions switch has temporarily a consumption of 250 mA, during 40 ms maximum only.

#### AVAILABILITY OF OPTIONS ACCORDING TO BOTH TYPE AND NUMBER OF POSITIONS

Type	Number of positions	Available options
0 or 1	3 to 12	0 - 1 - 2 - 3 - 4 - 8
2 or 3	3 to 6	0 - 1 - 2 - 3 - 4
	7 to 12	0 - 1 - 3 - 4
4 or 5	3 to 6	0 - 2
	7 to 12	Not Available
8 or 9	3 to 12	0 - 2 - 8

### COAXIAL SPnT up to 40 GHz – RAMSES Concept

#### GENERAL SPECIFICATIONS - RF PERFORMANCES

Connectors	SMA									
Number of positions	3 to 6					7 and 8				
Frequency range GHz	DC-3/DC - 18					DC-3/DC - 18				
	DC- 3	3 - 8	8 -12.4	12.4-18		DC- 3	3 - 8	8 -12.4	12.4-16	16-18
V.S.W.R. (max)	1.20	1.30	1.40	1.50		1.20	1.30	1.40	1.50	1.60
Insertion Loss (max) dB	.20	.30	.40	.50		.20	.30	.40	.55	.60
Isolation (min) dB	80	70	60	60		80	70	60	60	60

Connectors	SMA								
Number of positions	9 and 10					11 and 12			
Frequency range GHz	DC - 3 / DC - 18					DC-3/DC - 12.4			
	DC - 3	3 - 8	8 -12.4	12.4-15.5	15.5-18	DC - 3	3 - 8	8 -12.4	
V.S.W.R. (max)	1.20	1.30	1.40	1.50	1.70	1.20	1.40	1.80	
Insertion Loss (max) dB	.20	.30	.40	.50	.70	.20	.35	.70	
Isolation (min) dB	80	70	60	60	55	80	70	60	

Connectors	DIN1.6 / 5.6			SMA 2.9				
Number of positions	3 to 6			3 to 6				
Frequency range GHz	DC - 1			DC - 26.5 / DC - 40				
	DC - 0.5	0.5 - 1		DC - 6	6 - 12.4	12.4 - 18	18 - 26.5	26.5-40
V.S.W.R. (max)	1.25	1.30		1.30	1.40	1.50	1.70	2.20
Insertion Loss (max) dB	.15	.20		.20	.40	.50	.70	1.10
Isolation (min) dB	90	80		70	60	60	55	50

#### GENERAL SPECIFICATIONS - ADDITIONAL SPECIFICATIONS

Operating mode	Normally open or Latching			
	Normally open		Latching	
Actuator voltage (nominal) Vdc	12	28	12	28
Operating current at 23°C mA	250	102	See table page 49	
Average power	See Power Rating Chart page 9			
Peak power kW	1.5 (1 µs, 1 %)			
TTL INPUT High level / Low level	2.2 to 5.5 V ( TTL option ) / 3.5 to 5.5 ( BCD option ) 0 to 0.8 V ( TTL option ) / 0 to 1.5 V ( BCD option )			
Indicator rating	1 W - 30 V - 100 mA			
Switching time (max) ms	15 (for automatic reset models, SP3T to SP6T: 40 ms, SP7T to SP12T: 50 ms)			
Life	SP3 to 6T	SMA		SMA 2.9 / 1.6/5.6
		R573 serie	5 10 <sup>6</sup> cycles per way	
		R574 serie	2 10 <sup>6</sup> cycles per way	
	SP7 to 12T	2 10 <sup>6</sup> cycles per way		
Connectors	SMA , SMA 2.9 or 1.6/5.6			
Actuator terminals	Solder pins or DSUB			
Operating temperature range °C	-40, +85 (SMA & SMA 2.9) / -25,+70 (DIN1.6/5.6)			
Storage temperature range °C	-55, +85 (SMA & SMA 2.9) / -40 , +85 (DIN1.6/5.6)			
Impedance Ω	SMA & SMA 2.9		DIN 1.6/5.6	
	50		75	
For terminated models	50 Ω termination ±5% 1 Watt per termination 3 W total power handling per switch			
Switching sequence	Break Before Make			

### COAXIAL SPnT up to 40 GHz – RAMSES Concept



### TYPICAL OUTLINE DRAWING

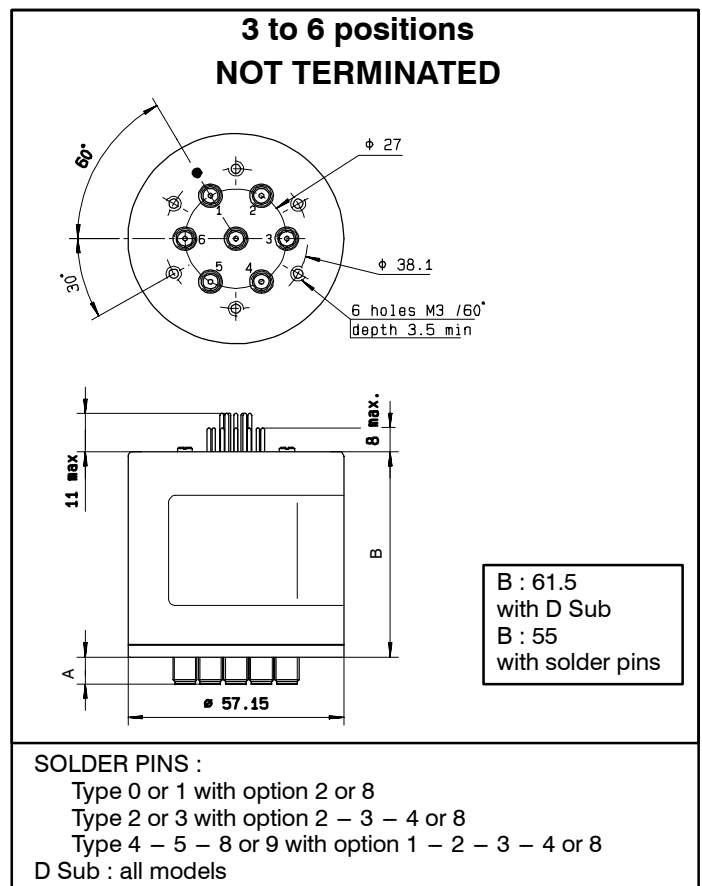
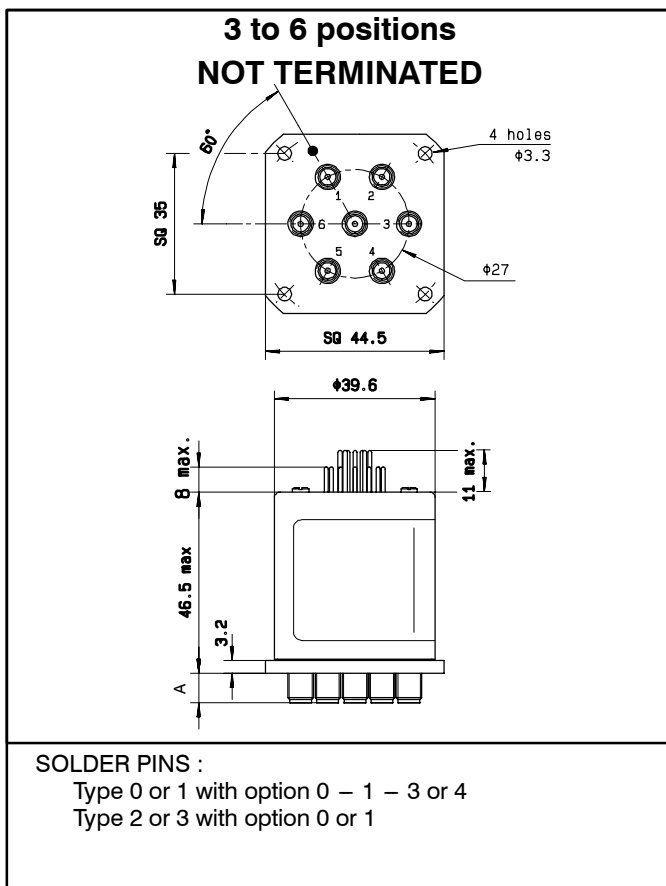

Connectors	SMA	SMA 2.9	DIN 1.6/5.6
A max ( mm )	7.4	6.3	11.5