

**STRAIGHT PLUG FULL CRIMP TYPE**

**R123.096.110**

**CABLE 5/50S**

Series : QMA

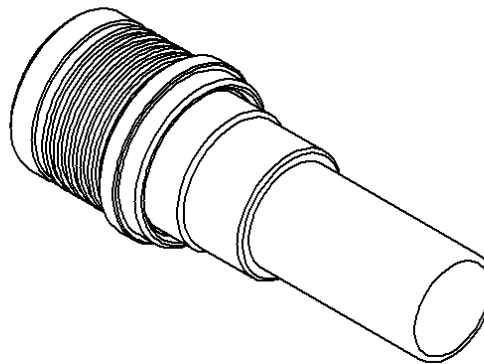
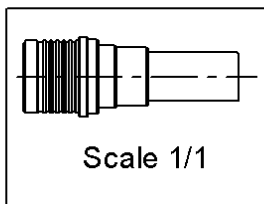
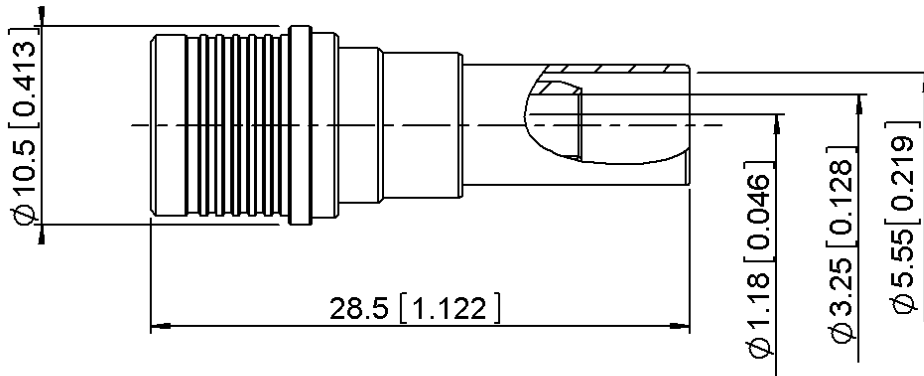

All dimensions are in mm.

COMPONENTS	MATERIALS	PLATING (µm)
BODY	BRASS.	BBR2
CENTER CONTACT	BRASS.	Cu2.5 Au1.3
OUTER CONTACT	BRASS.	BBR2
INSULATOR	PTFE	
GASKET		
OTHERS PARTS	BRASS.	BBR2
-	-	-
-	-	-

Issue : 1306 B

In the effort to improve our products, we reserve the right to make changes judged to be necessary.



**STRAIGHT PLUG FULL CRIMP TYPE**

**R123.096.110**

**CABLE 5/50S**

Series : QMA

**PACKAGING**

Standard	Unit	Other
<b>100</b>	<b>'W' option</b>	<b>Contact us</b>

**SPECIFICATION**

**ELECTRICAL CHARACTERISTICS**

Impedance	<b>50</b>	$\Omega$
Frequency	<b>0-6</b>	GHz
VSWR	<b>TBD + 0,0000</b>	x F(GHz) Maxi
Insertion loss	<b>TBD</b>	$\sqrt{F}$ (GHz) dB Maxi
RF leakage	<b>- ( 80</b>	- F(GHz)) dB Maxi
Voltage rating	<b>335</b>	Veff Maxi
Dielectric withstanding voltage	<b>1000</b>	Veff mini
Insulation resistance	<b>5000</b>	M $\Omega$ mini

**CABLE ASSEMBLY**

Stripping	a	b	c	d	e	f
mm	4,00	6,30	11,1	0,00	7,10	0,00

Assembly instruction : **Crimp 03\***

Recommended cable(s)  
LMR 200  
AEP-200FR

**MECHANICAL CHARACTERISTICS**

Center contact retention		
Axial force – Mating end	<b>18</b>	N mini
Axial force – Opposite end	<b>18</b>	N mini
Torque	<b>NA</b>	N.cm mini

Characteristics indicated on this data sheet are those that can be achieved with the highest performance cable. Intrinsic limitations of the cable may diminish the performance of the assembly

Cable retention

- pull off	<b>220</b>	N mini
- torque	<b>NA</b>	N.cm

**TOOLING**

Part Number	Description	Hexagon
R282.223.000	CRIMPING TOOL	5.41
R282.281.000	CRIMPING TOOL	
R282.967.013	POSITIONER FOR CRIMPING TOOL	2x4 POS. 6

Recommended torque		
Mating	<b>NA</b>	N.cm
Panel nut	<b>NA</b>	N.cm
Clamp nut	<b>NA</b>	N.cm
A/F clamp nut	<b>0,0000</b>	mm
Mating life	<b>100</b>	Cycles mini
Weight	<b>3,2840</b>	g

**OTHER CHARACTERISTICS**

\*prior to step two of Crimp 03, slide disk insulator onto center conductor, and bottom contact on disk insulator

**ENVIRONMENTAL**

Operating temperature	<b>-40/+80</b>	$^{\circ}$ C
Hermetic seal	<b>NA</b>	Atm.cm3/s
Panel leakage	<b>NA</b>	

Issue : 1306 B

In the effort to improve our products, we reserve the right to make changes judged to be necessary.

