

QPC1217Q

General Purpose DPDT Transfer Switch

Product Description

The QPC1217Q is a dual-pole double-throw transfer switch designed for general purpose switching applications where RF port transfer (port swapping) control is needed. The low insertion loss along with excellent linearity performance makes the QPC1217Q ideal for multi-mode GSM, EDGE, UMTS, LTE, V2X, and DSRC applications. The RF ports can be directly connected in 50Ω systems and control logic is compatible with 1.3V to 2.7V systems. The supply voltage is intended for connection to 2.8V systems but the device is operable from 2.6V to 5.5V. The compact 1.1mm x 1.5mm size offers designers an easy-to-use switch component for quick integration into multimode, multi-band, multi-technology systems.

Functional Block Diagram

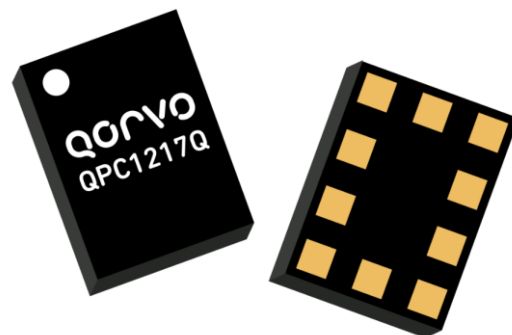
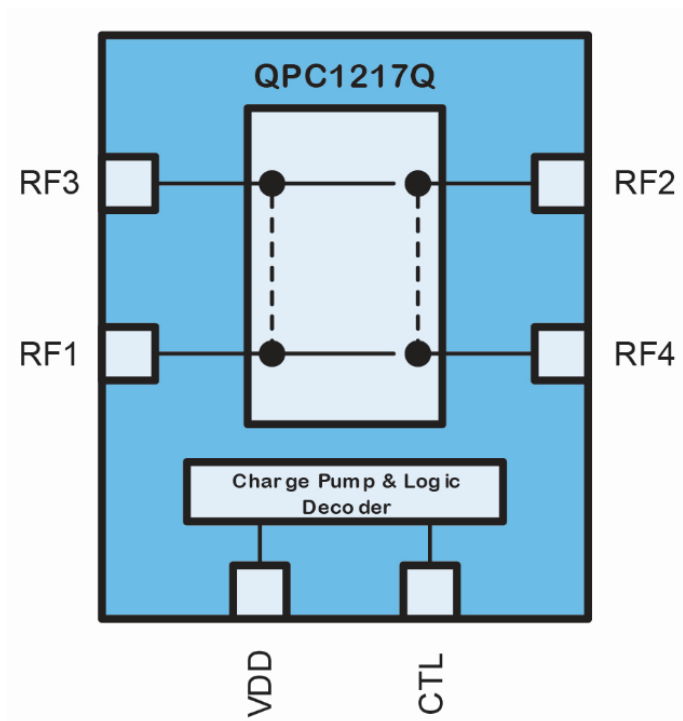

10 Pin 1.1 x 1.5 x 0.92 mm Package

Feature Overview

- Tested in accordance to AEC-Q100 Grade 2
- Low Insertion Loss
- High Port-to-Port Isolation
- GPIO Interface for 1.3V to 2.7V Control Logic
- Broadband Performance Suitable for All Cellular/WiFi/BT/V2X
- Operation up to 6GHz
- Very Low Current Consumption
- Linearity and Harmonic Performance Ideally Suited for LTE, V2X Applications
- DC blocking capacitors are not required in typical applications

Applications

- V2X, DSRC, eCall, WiFi
- General purpose switching up to 6GHz
- Multi-Mode GSM, EDGE, WCDMA, and LTE Applications

Ordering Information

PART NO.	DESCRIPTION
QPC1217QSB	5-pc Sample Bag
QPC1217QSR	100-pc Reel
QPC1217QTR13-5K	5000-pc Reel
QPC1217QPCK01	Fully Assembled EVB + 5 piece SB

General Purpose DPDT Transfer Switch

Absolute Maximum Ratings

PARAMETER	RATING
Storage Temperature	-65 to +150 °C
Ambient Operating Temperature	-40 to +105°C
V _{DD}	6.0 V
C _{TL1}	3.0 V
Maximum Junction Temperature	+125°C
Maximum Input Power	<20MHz operation requires MPR of 1dB
Single Drive	36.0 dBm, 1:1 VSWR, +85°C, 100% DC 33.5 dBm, 1:1 VSWR, +105°C, 100% DC
Dual Drive	33.5 dBm, 1:1 VSWR, +85°C, 100% DC 30.5 dBm, 1:1 VSWR, +105°C, 100% DC

Operation of this device outside the parameter ranges given above may cause permanent damage.

Recommended Operating Conditions

PARAMETER	CONDITIONS	MIN.	TYP.	MAX.	UNITS
V _{DD} Supply Voltage		2.6	2.8	5.5	V
V _{DD} Supply Current			57	80	µA
C _{TL} Logic Low Voltage		0.0	0.1	0.45	V
C _{TL} Logic High Voltage		1.3	1.8	2.7	V
C _{TL} Logic High Current			0.58	5	µA
Turn-On Time	50% V _{dd} to 10/90% RF		2.28	20	µs
Switching Speed	50% Control to 10/90% RF		1.42		µs

Electrical specifications are measured at specified test conditions. Specifications are not guaranteed over all recommended operating conditions.

General Purpose DPDT Transfer Switch

Electrical Specifications

Test conditions unless otherwise stated: all unused RF ports terminated in 50Ω, Input and Output = 50Ω, T = 25°C, V_{DD} = 2.8V, Logic State = RF1-RF4; RF2-RF3 and RF1-RF3; RF2-RF4

PARAMETER	CONDITIONS	MIN.	TYP.	MAX.	UNITS
Frequency Range		698		960	MHz
Insertion Loss					
RF1 to RF3	Logic State = RF1-RF3, RF2-RF4		0.32	0.45	dB
RF1 to RF4	Logic State = RF1-RF4, RF2-RF3		0.33	0.45	dB
RF2 to RF3	Logic State = RF1-RF4, RF2-RF3		0.34	0.45	dB
RF2 to RF4	Logic State = RF1-RF3, RF2-RF4		0.33	0.45	dB
Isolation					
RF1 to RF2, RF3 to RF4	Logic State = RF1-RF4, RF2-RF3	26	33.6		dB
RF1 to RF2, RF3 to RF4	Logic State = RF1-RF3, RF2-RF4	26	30.1		dB
Harmonics					
2 nd Harmonic	Frequency = 980MHz; Pin = 26dBm; CW		-108.1		dBm
3 rd Harmonic			-85.6		dBm
IIP2					
Band 5 & 6			137.44		dBm
IIP3					
Band 5 & 6			74.5		dBm
VSWR					
RF1, RF2, RF3, RF4	824MHz to 960MHz		1.1		:1

General Purpose DPDT Transfer Switch

PARAMETER	CONDITIONS	MIN.	TYP.	MAX.	UNITS
Frequency Range		1425		2200	MHz
Insertion Loss					
RF1 to RF3	Logic State = RF1-RF3, RF2-RF4		0.39	0.5	dB
RF1 to RF4	Logic State = RF1-RF4, RF2-RF3		0.39	0.5	dB
RF2 to RF3	Logic State = RF1-RF4, RF2-RF3		0.42	0.5	dB
RF2 to RF4	Logic State = RF1-RF3, RF2-RF4		0.39	0.5	dB
Isolation					
RF1 to RF3, RF2-RF4	Logic State = RF1-RF4, RF2-RF3	22	27.8		dB
RF1 to RF4, RF2-RF3	Logic State = RF1-RF3, RF2-RF4	22	24.4		dB
Harmonics					
2 nd Harmonic	Frequency = 2010MHz; P _{in} = 26dBm; CW		-100.2		dBm
3 rd Harmonic			-101.2		dBm
IIP2					
Band 2 (PCS)			129.9		dBm
IIP3					
Band 2 (PCS)			73.9		dBm
VSWR					
RF1, RF2, RF3, RF4	1427MHz to 2170MHz		1.15		:1
Frequency Range		2300		2690	MHz
Insertion Loss					
RF1 to RF3	Logic State = RF1-RF3, RF2-RF4		0.41	0.6	dB
RF1 to RF4	Logic State = RF1-RF4, RF2-RF3		0.41	0.6	dB
RF2 to RF3	Logic State = RF1-RF4, RF2-RF3		0.45	0.6	dB
RF2 to RF4	Logic State = RF1-RF3, RF2-RF4		0.42	0.6	dB
Isolation					
RF1 to RF3, RF2-RF4	Logic State = RF1-RF4, RF2-RF3	20	25		dB
RF1 to RF4, RF2-RF3	Logic State = RF1-RF3, RF2-RF4	20	22		dB
Harmonics					
2 nd Harmonic	Frequency = 2700MHz; P _{in} = 26dBm; CW		-100.3		dBm
3 rd Harmonic			-92.7		dBm
IIP2					
Band 7			129.5		dBm
IIP3					
Band 7			71.7		dBm
VSWR					
RF1, RF2, RF3, RF4	2300MHz to 2690MHz		1.17		:1

General Purpose DPDT Transfer Switch

PARAMETER	CONDITIONS	MIN.	TYP.	MAX.	UNITS
Frequency Range		5000		6000	MHz
Insertion Loss					
RF1 to RF3	Logic State = RF1-RF3, RF2-RF4		0.76		dB
RF1 to RF4	Logic State = RF1-RF4, RF2-RF3		0.69		dB
RF2 to RF3	Logic State = RF1-RF4, RF2-RF3		0.86		dB
RF2 to RF4	Logic State = RF1-RF3, RF2-RF4		0.79		dB
Isolation					
RF1 to RF3, RF2-RF4	Logic State = RF1-RF4, RF2-RF3		18.5		dB
RF1 to RF4, RF2-RF3	Logic State = RF1-RF3, RF2-RF4		16		dB
VSWR					
RF1, RF2, RF3, RF4	5000MHz to 6000MHz		1.41		:1

General Purpose DPDT Transfer Switch

Application Circuit Schematic

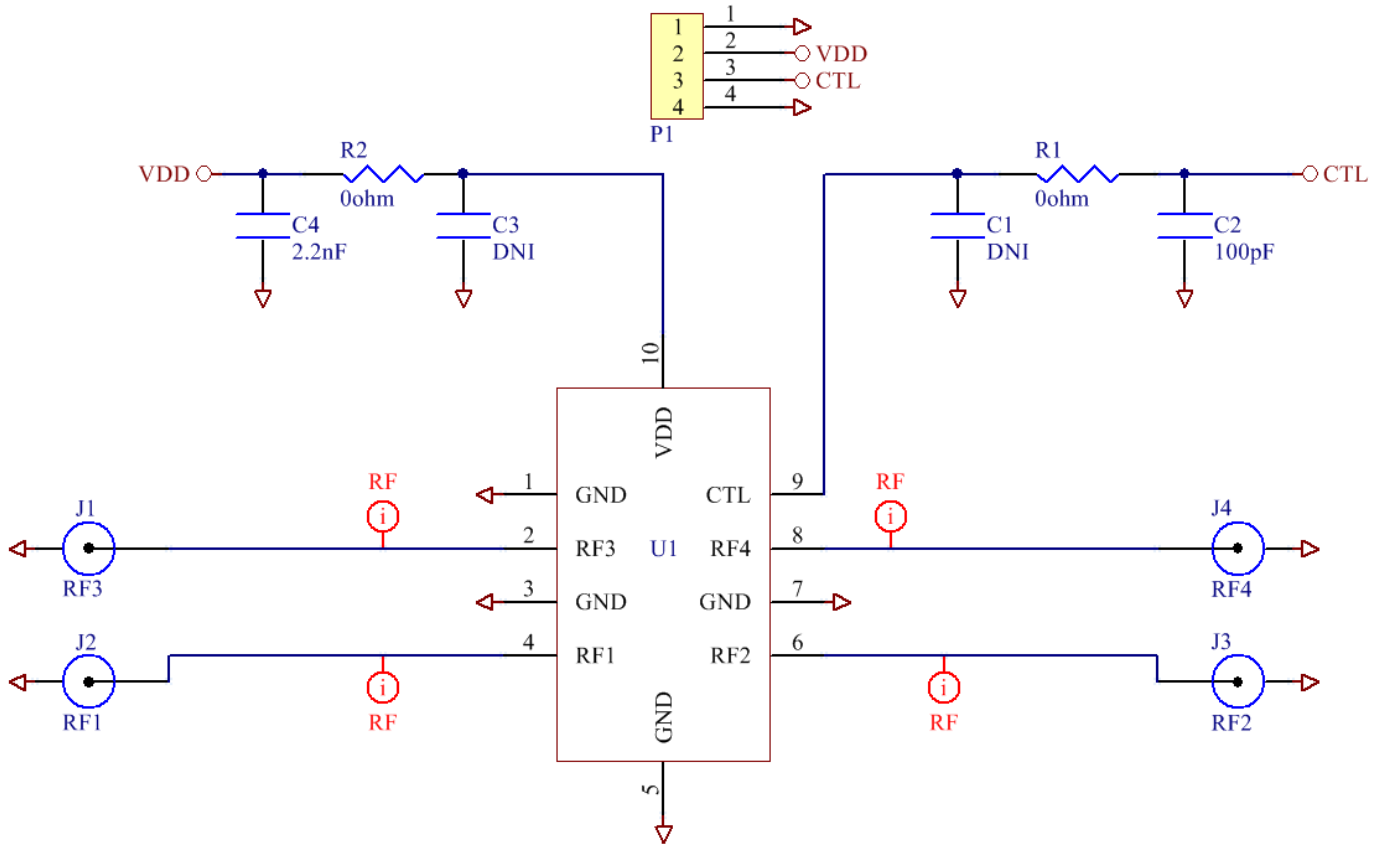

General Purpose DPDT Transfer Switch

Pin Configuration and Description

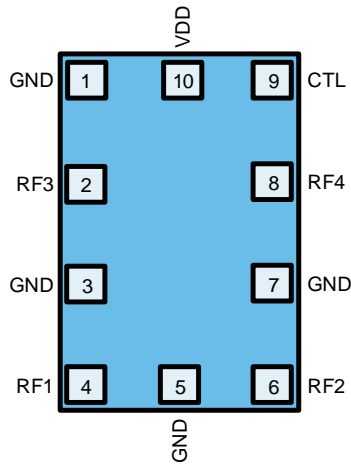

Top View

PIN NO.	LABEL	DESCRIPTION
1	GND	Ground
2	RF3	RF Port connecting to either RF1 or RF2. Avoid applying DC voltage
3	GND	Ground
4	RF1	RF Port connecting to either RF3 or RF4. Avoid applying DC voltage
5	GND	Ground
6	RF2	RF Port connecting to either RF3 or RF4. Avoid applying DC voltage
7	GND	Ground
8	RF4	RF Port connecting to either RF1 or RF2. Avoid applying DC voltage
9	C _{TL}	Logic Control pin
10	V _{DD}	Power Supply pin

Control Logic

The Switch is controlled by V_{DD} and C_{TL}.

LOGIC STATE	V _{DD}	C _{TL}	DESCRIPTION
Off	0V	Low	Off or Standby – low current state
RF1-RF3;RF2-RF4	“V _{DD} ”	Low	RF1 connected to RF3 and RF2 connected to RF4
RF1-RF4;RF2-RF3	“V _{DD} ”	High	RF1 connected to RF4 and RF2 connected to RF3

NOTE: The switch is in the Off or Standby state only when the V_{DD} supply is low. The RF performance is undefined in the Off State

General Purpose DPDT Transfer Switch

Power On and Off Sequence

It is very important that the user adheres to the correct power-on/off sequence in order to avoid damaging the part. First apply V_{DD} before applying a high to C_{TL} .

Power On –

1. Apply voltage supply – V_{DD}
2. Apply Logic signal – C_{TL}
3. Wait $5\mu s$ or greater after C_{TL} is stable and then apply the RF signal

Power Off –

1. Remove the RF signal
2. Remove the logic signal – C_{TL}
3. Remove the voltage supply – V_{DD}

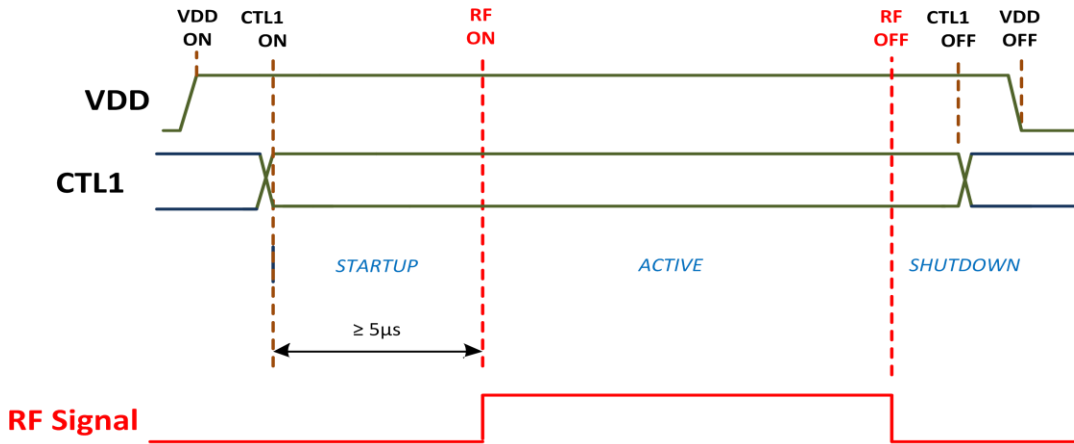

General Purpose DPDT Transfer Switch

Mechanical Information

Package Drawing

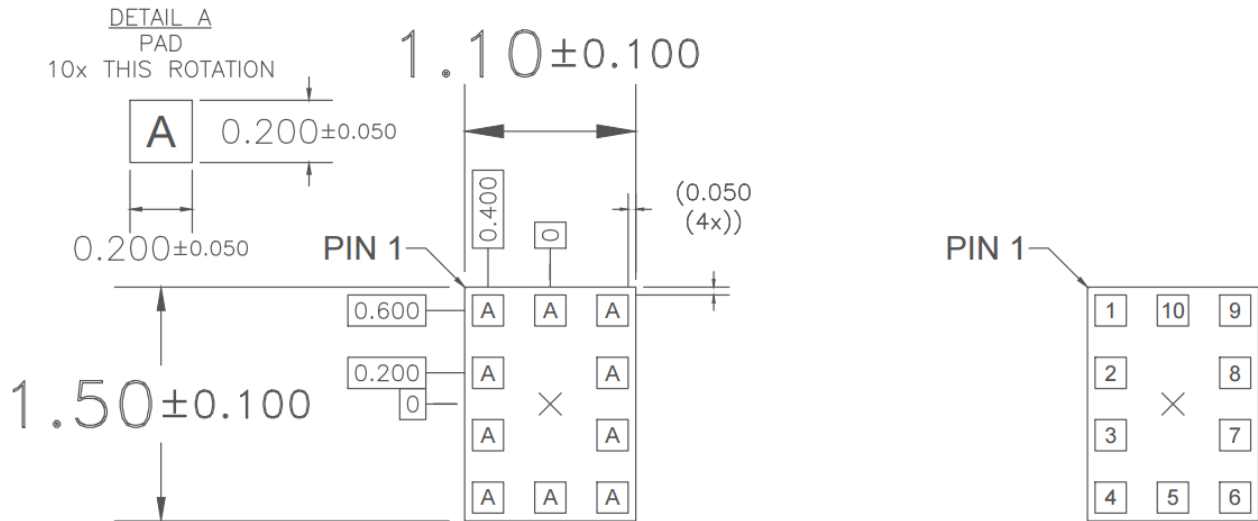
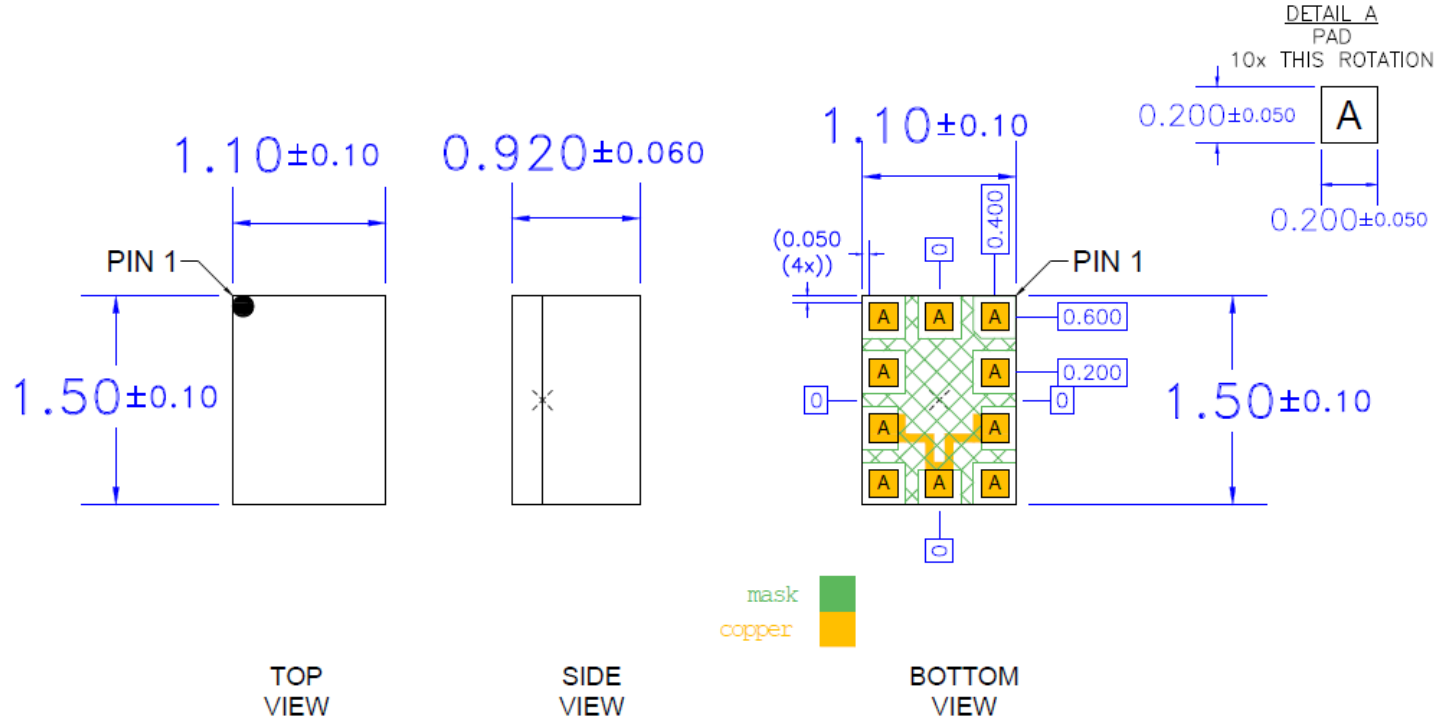

General Purpose DPDT Transfer Switch

PCB Design Requirements

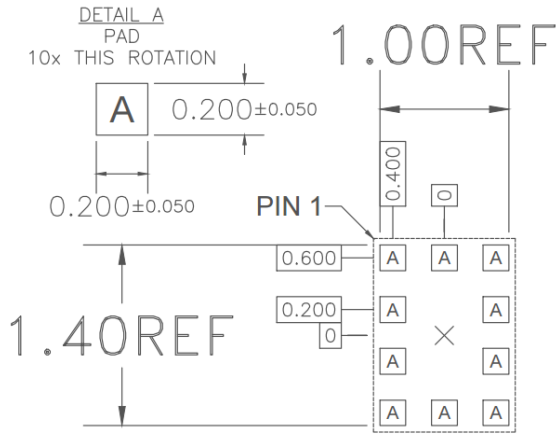

Recommended Land Pattern

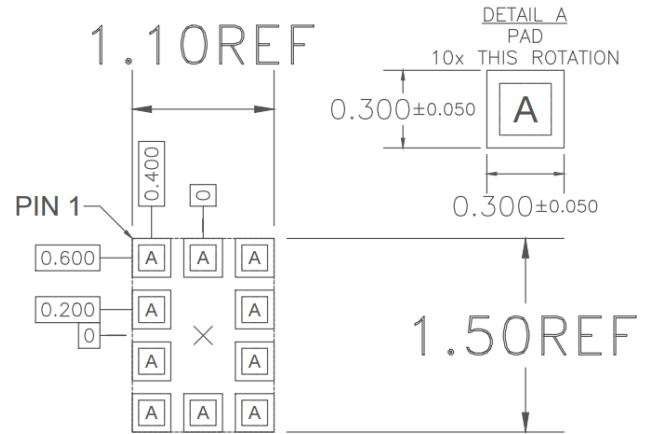

Recommended Land Pattern Mask

Notes:

1. All dimensions are in millimeters. Angles are in degrees.
2. Dimension and tolerance formats conform to ASME Y14.4M-1994.
3. The terminal #1 identifier and terminal numbering conform to JESD 95-1 SPP-012.

General Purpose DPDT Transfer Switch

Handling Precautions

PARAMETER	RATING	STANDARD
ESD – Human Body Model (HBM)	Class 2	ESDA/JEDEC JS-001-2012
MSL – Moisture Sensitivity Level	Level 3	IPC/JEDEC J-STD-020



Caution!

ESD sensitive device

Solderability

Compatible with both lead-free (260 °C max. reflow temperature) and tin/lead (245 °C max. reflow temperature) soldering processes.

Package lead plating: Electrolytic plated Au over Ni

RoHS Compliance

This part is compliant with the 2011/65/EU RoHS directive (Restrictions on the Use of Certain Hazardous Substances in Electrical and Electronic Equipment), as amended by Directive 2015/863/EU.

This product also has the following attributes:

- Lead free
- Halogen Free (Chlorine, Bromine)
- Antimony Free
- TBBP-A (C₁₅H₁₂Br₄O₂) Free
- SVHC Free



Contact Information

For the latest specifications, additional product information, worldwide sales and distribution locations:

Web: www.qorvo.com

Tel: 1-844-890-8163

Email: customer.support@qorvo.com

Important Notice

The information contained herein is believed to be reliable. Qorvo makes no warranties regarding the information contained herein. Qorvo assumes no responsibility or liability whatsoever for any of the information contained herein. Qorvo assumes no responsibility or liability whatsoever for the use of the information contained herein. The information contained herein is provided "AS IS, WHERE IS" and with all faults, and the entire risk associated with such information is entirely with the user. All information contained herein is subject to change without notice. Customers should obtain and verify the latest relevant information before placing orders for Qorvo products. The information contained herein or any use of such information does not grant, explicitly or implicitly, to any party any patent rights, licenses, or any other intellectual property rights, whether with regard to such information itself or anything described by such information.

Qorvo products are not warranted or authorized for use as critical components in medical, life-saving, or life-sustaining applications, or other applications where a failure would reasonably be expected to cause severe personal injury or death.

Copyright 2016 © Qorvo, Inc. | Qorvo is a registered trademark of Qorvo, Inc.