

RFFM6906

3.1V to 4.0V, 915MHz Transmit/Receive Module

This module is intended for 868MHz and 915MHz AMR solutions. The FEM provides separate ports for Rx/Tx paths, single-ended Tx and single-ended Rx or Rx differential port, 12dB gain single stage LNA, and single port antenna connection. The PA section provides a nominal output power of 30dBm. The device is provided in a 5.5mm x 5.0mm, 28-pin package.



Package: LGA, 28-pin,
5.5mm x 5.0mm

Features

- Tx Output Power: 30dBm
- Separate 50Ω Tx/Rx Transceiver Interface
- Optional 75Ω Rx Differential Transceiver Interface
- Rx Gain: 12dB

Applications

- Wireless Automated Metering
- Wireless Alarm Systems
- Portable Battery Powered Equipment
- Smart Energy
- 868MHz/900MHz ISM Band Application
- Single Chip RF Front End Module

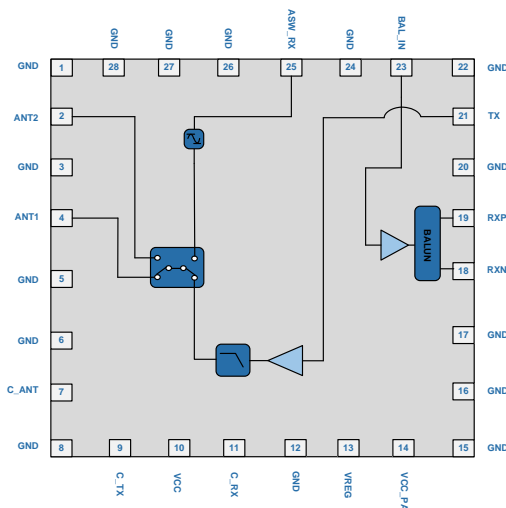

Functional Block Diagram

Ordering Information

RFFM6906SB	Standard 5-piece bag
RFFM6906SQ	Standard 25-piece bag
RFFM6906SR	Standard 100-piece reel
RFFM6906TR13	Standard 2500-piece reel
RFFM6906PCK-410	Fully assembled eval board with 5 loose pieces

Absolute Maximum Ratings

Parameter	Rating	Unit
Battery Voltage	5.5	V
Operating Temperature	-40 to 85	°C
Storage Temperature	-40 to 150	°C
ESD, HBM (all pins)	500	V
ESD, CDM (all pins)	500	V
MSL	MSL 3	
Maximum Input Power to PA	+20	dBm



Caution! ESD sensitive device.



RFMD Green: RoHS status based on EU Directive 2011/65/EU (at time of this document revision), halogen free per IEC 61249-2-21, < 1000ppm each of antimony trioxide in polymeric materials and red phosphorus as a flame retardant, and <2% antimony in solder.

Exceeding any one or a combination of the Absolute Maximum Rating conditions may cause permanent damage to the device. Extended application of Absolute Maximum Rating conditions to the device may reduce device reliability. Specified typical performance or functional operation of the device under Absolute Maximum Rating conditions is not implied.

Nominal Operating Parameters

Parameter	Specification			Unit	Condition
	Min	Typ	Max		
Frequency	865	902 to 928		MHz	
RF Port Impedance		50		Ω	Single-ended
		75		Ω	Balanced; RX_P and RX_N
Total Leakage Current		2		μA	V _{BATT} = 3.1V/3.6V/4V, V _{REG} = 0V, C _{TX} = 0V, C _{RX} = 0V
PA Section					V_{CC} = 3.6V, V_{REG} = 3.4V, C_{TX} = 3.4V, C_{RX} = 0V, Temperature = 25°C; P_{OUT} = 30dBm. Unless otherwise specified.
CW P _{OUT} Saturation	30	31	32	dBm	
Large Signal Gain	24	27		dB	
Thermal Resistance		41		°C/W	V _{CC} = 3.6V, V _{REG} = 3.4V, C _{TX} = 3.4V, C _{RX} = 0V, T _{REF} = 85°C, P _{OUT} = 30dBm
2F ₀		-40	-35	dBc	
3F ₀ to 10F ₀		-70		dBc	F ₀ = 865MHz
		-75	-72	dBc	F ₀ = 902MHz to 928MHz
Input Return Loss	10			dB	
Output Return Loss		10		dB	
Battery Voltage	3.3	3.6	4.0	V	V _{CC}
Operating Current		650	750	mA	F ₀ = 902 – 928 MHz
		700	800	mA	F ₀ = 865 – 868 MHz
Quiescent Current		115		mA	No RF
V _{REG}	3.1	3.4	V _{CC} -0.2	V	
V _{REG} Current		1.5	2	mA	
RX Switch Section					V_{CC} = 3.6V, V_{REG} = 0V, C_{TX} = 0V, C_{RX} = 3.4V, Temperature = 25°C; Unless otherwise specified
Insertion Loss		1.5	1.7	dB	ANT1/ANT2 to ASW_RX
Input Return Loss	10	12		dB	
Output Return Loss	10	12		dBm	

Parameter	Specification			Unit	Condition
	Min	Typ	Max		
Power Limiter			10	dBm	ASW_RX Port

RX LNA Section					V _{CC} = 3.6V, V _{REG} = 0V, C _{TX} = 0V, C _{RX} = 3.4V, Temperature = 25°C; Unless otherwise specified
RX Gain	12	14	16	dB	75Ω Balanced
Noise Figure		2.0	2.2	dB	
Input IP3	1	3		dBm	
Input Return Loss	10	12		dB	50Ω Single-ended
Output Return Loss	10	12		dB	75Ω Balanced
LNA Current	6	8	10	mA	
Antenna Switch Section					
Isolation	20			dB	Any used port to any unused port
Logic Voltage, High	3.1	3.4	V _{CC} -0.2	V	All Logic I/Os
Logic Voltage, Low	0.0		0.2	V	All Logic I/Os
Logic Current, High		5	10	mA	All Logic I/Os
Logic Current, Low		0.4		mA	All Logic I/Os

Module Logic Truth Table

Operating Mode	C_TX	C_RX	C_ANT	VREG
TX-ANT1	1	0	0	3.4V
TX-ANT2	1	0	1	3.4V
RX-ANT1	0	1	0	0V
RX-ANT2	0	1	1	0V
All Off	0	0	0	0V

Notes:

1. Switch Control Logic High = Min 3.1V to Max 3.8V
2. Switch Control Logic Low = Min 0.0V to Max 0.4V

Application Schematic

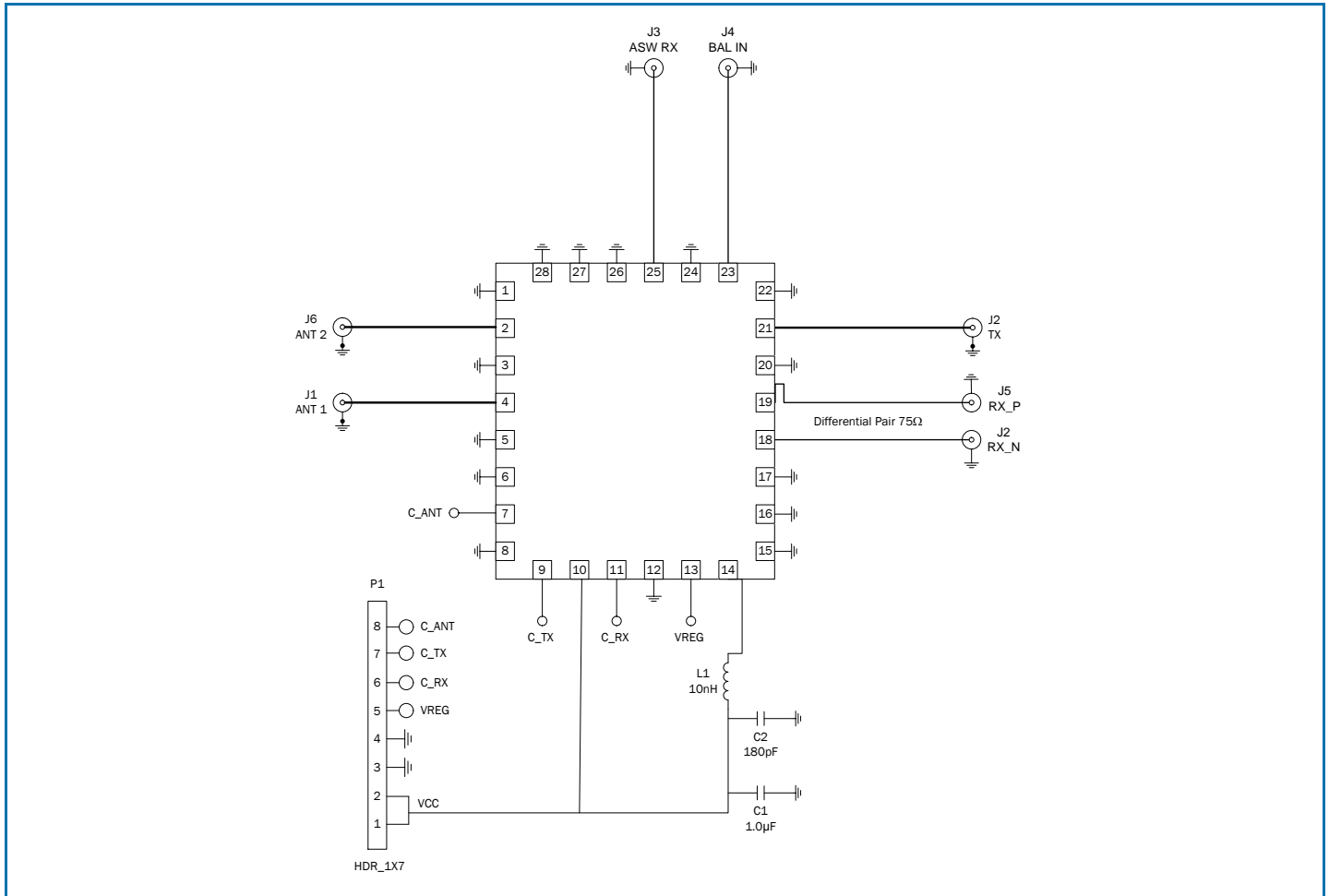

Pin Out

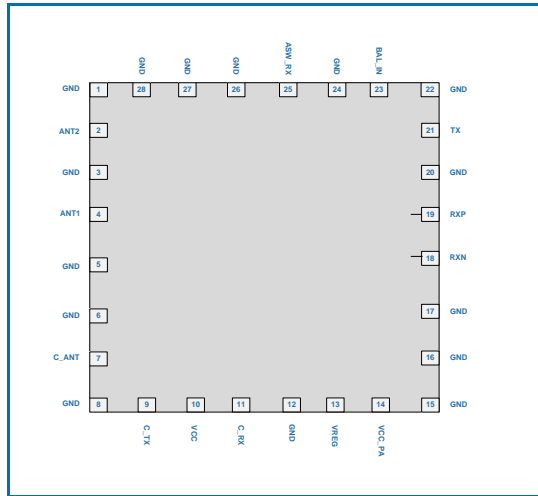

Package Drawing

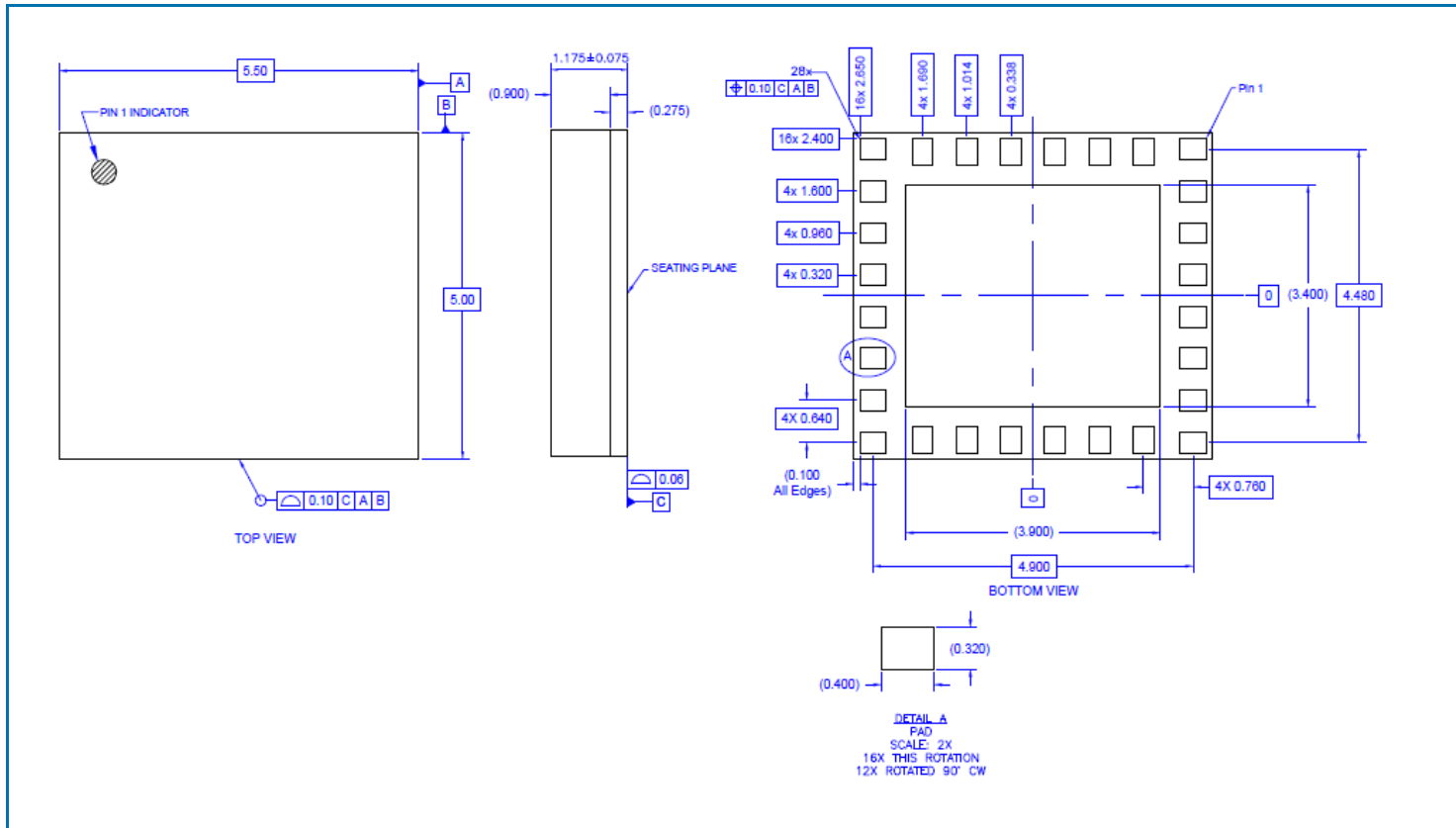

PCB Patterns

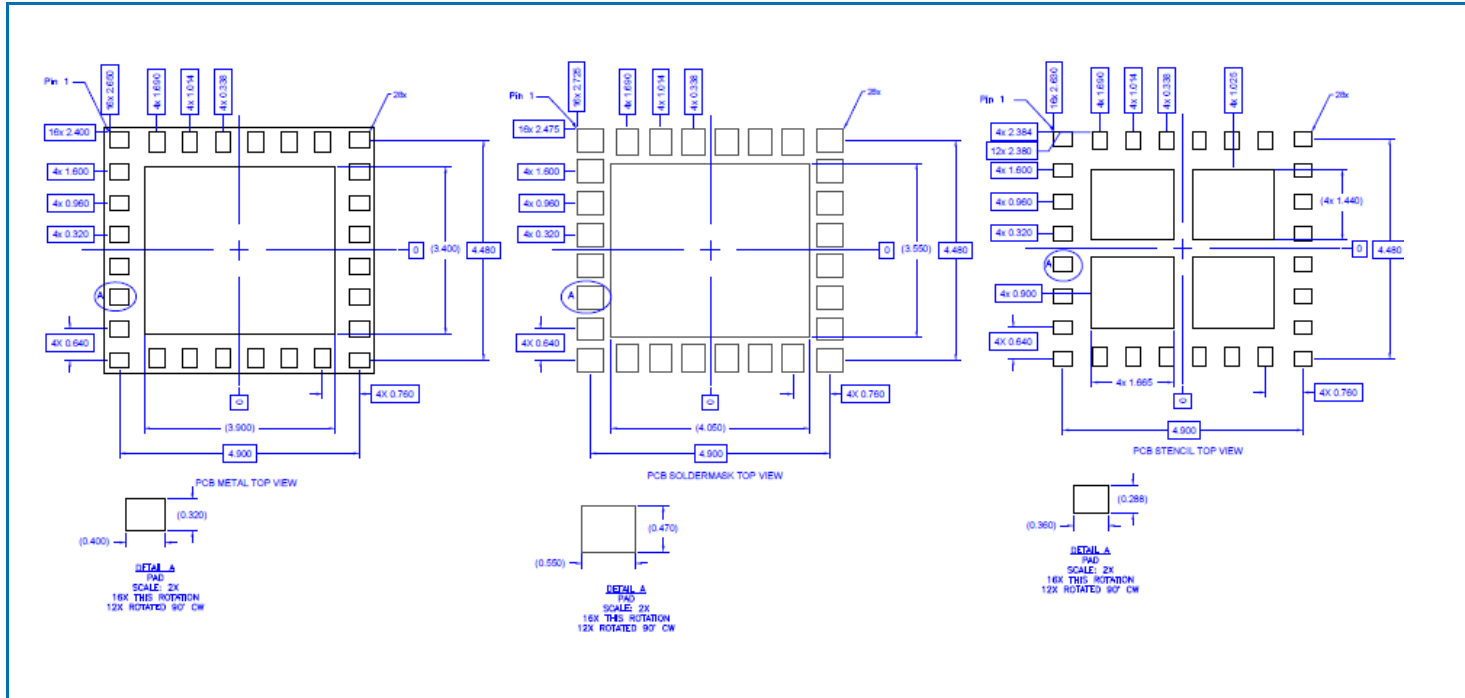

Pin Names and Descriptions

Pin	Name	Description
1	GND	Ground
2	ANT2	Antenna 2 Connect Port
3	GND	Ground
4	ANT1	Antenna 1 Connect Port
5	GND	Ground
6	GND	Ground
7	C_ANT	Antenna Selection Control Line
8	GND	Ground
9	C_TX	Transmit Selection Control Line
10	VCC	Supply Voltage
11	C_RX	Receive Selection Control Line
12	GND	Ground
13	VREG	Power Amplifier Bias Control. $V_{CC} - 0.2V = ON$, $0V = OFF$
14	VCC_PA	Power Amplifier Supply Voltage
15	GND	Ground
16	GND	Ground
17	GND	Ground
18	RXN	Receive Port Negative
19	RXP	Receive Port Positive
20	GND	Ground
21	TX	Transmit Port
22	GND	Ground
23	BAL_IN	Input to Balun
24	GND	Ground
25	ASW_RX	Antenna Switched Rx Output
26	GND	Ground
27	GND	Ground
28	GND	Ground