

Product Description

The QPB8808 is an ultra-linear, QFN GaAs amplifier MMIC intended for output stage amplification in CATV infrastructure applications.

The device features a push-pull cascode design which provides flat gain along with ultra-low distortion, making it ideal for use in CATV distribution systems requiring high output power capability.

The QPB8808 draws approximately 525 mA from a single +12 V supply providing ~20 dB gain with excellent linearity. Users may adjust the bias current with external voltage enabling the QPB8808 to be used in applications such as doublers or for lower power system applications.

The QPB8808 is packaged in an industry standard 40 pin 5 x 7 mm QFN package with exposed paddle (EP) beneath the device for thermal and electrical grounding

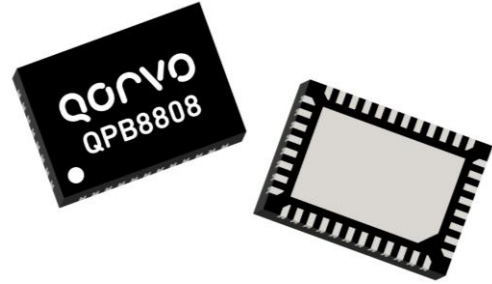

40 Pin 5 x 7 mm QFN Package

Product Features

- 50 – 1218 MHz Bandwidth
- Excellent High Output Linearity at Reduced Supply Voltages
- Ultra-Low CSO / CTB / XMOD
- Low Noise
- Excellent Input/Output Return Loss
- High Gain, 20.6 dB typ. at 1218 MHz
- Settable bias current
- Compact 5 X 7 mm QFN Package
- +12 V Supply Voltage
- 525 mA Operating Current

Functional Block Diagram

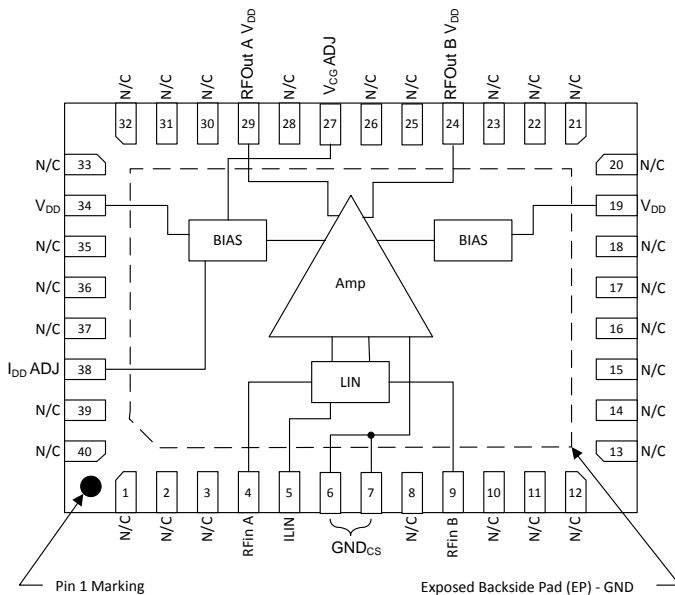

Applications

- HFC Nodes
- CATV Line Amplifiers
- Head End Equipment
- 50 – 1218 MHz 75 Ω Amplifier

Ordering Information

Part No.	Description
QPB8808SQ	Sample bag 25 pcs
QPB8808SR	7" Reel with 100 pcs
QPB8808TR13	13" Reel with 2500 pcs
QPB8808PCK401	EVB with 5-piece sample bag

Absolute Maximum Ratings

Parameter	Value / Range
Storage Temperature	-40 to 100 °C
Operating Temperature	-40 to 85 °C
Device Voltage (V _{DD})	+18 V
Device Current (I _{DD})	650 mA

Operation of this device outside the parameter ranges given above may cause permanent damage.

Recommended Operating Conditions

Parameter	Min	Typ	Max	Units
Device Voltage (V _{DD})		+12		V
T _j for >10 ⁶ hours MTTF			150	°C

Electrical specifications are measured at specified test conditions. Specifications are not guaranteed over all recommended operating conditions.

Electrical Specifications

Parameter	Conditions	Min	Typ	Max	Units	
Operational Frequency Range	–	50	–	1218	MHz	
Current (I _{DD})	–	–	525	–	mA	
Gain	f _o = 1218 MHz	–	20.6	–	dB	
Gain Flatness	50 to 1218 MHz ⁽¹⁾	–	±0.5	–		
Gain Tilt	50 to 1218 MHz ⁽²⁾	–	+0.75	–		
Input Return Loss	f _o = 50 MHz		20	–	dB	
	f _o = 1003 MHz	–	15	–		
	f _o = 1218 MHz	–	14	–		
Output Return Loss	f _o = 50 MHz	–	20	–	dB	
	f _o = 1003 MHz	–	18	–		
	f _o = 1200 MHz	–	15	–		
CSO	V _o = 57dBmV at 1218 MHz, 22 dB extrapolated tilt, 79 analog channels plus 111 digital channels (-6dB offset)	Notes 3,4	–	-78	–	dBc
CTB			–	-79	–	dBc
CCN			–	58	–	dB
OIP2	f ₁ - f ₂ = 50 MHz, +17 dBm / tone	Notes 3,4	–	+85	–	dBm
OIP3	f ₁ =550 MHz, f ₂ =555 MHz, +17 dBm / tone		–	+50	–	dBm
P1dB	f _o =550 MHz		–	+33	–	dBm
Noise Figure	f _o =1218 MHz	–	4.5	–	dB	
Thermal Resistance, θ _{jb}	Junction to base	–	7	–	°C/W	

Notes:

1. Maximum deviation from a line using least squares fit across the band 50 to 1218 MHz
2. Gain of S21 at 1218MHz–S21 at 50 MHz
3. Standard EB configuration
4. ILIN resistor R1 set to 910 ohms, changing value may further optimize IMD performance

QPB8808PCK401 Evaluation Board

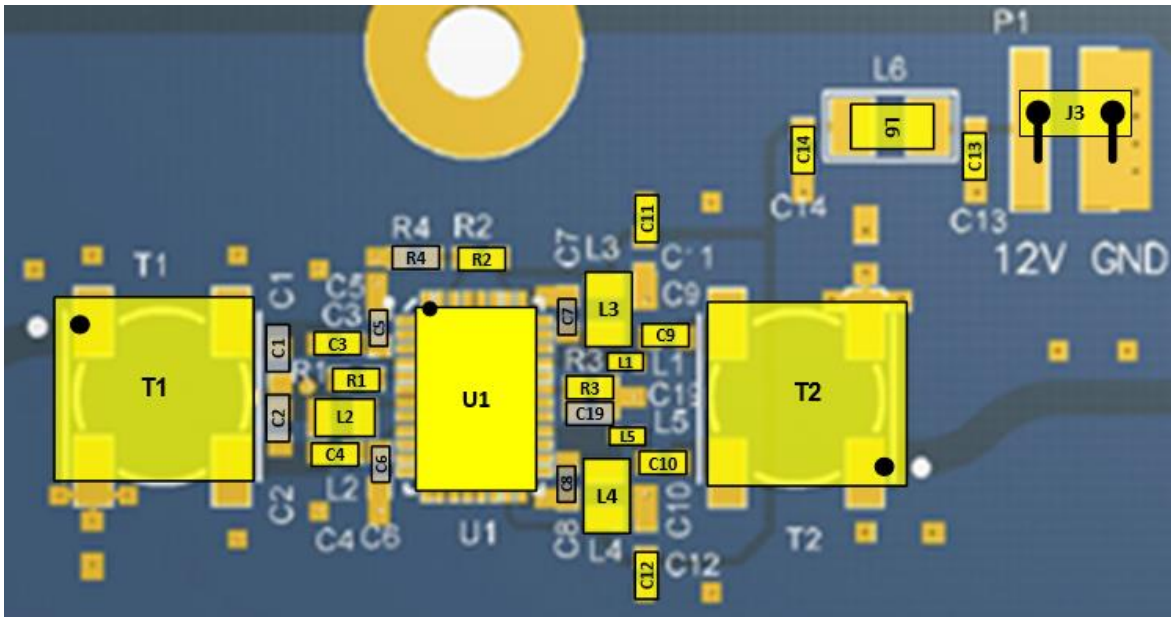
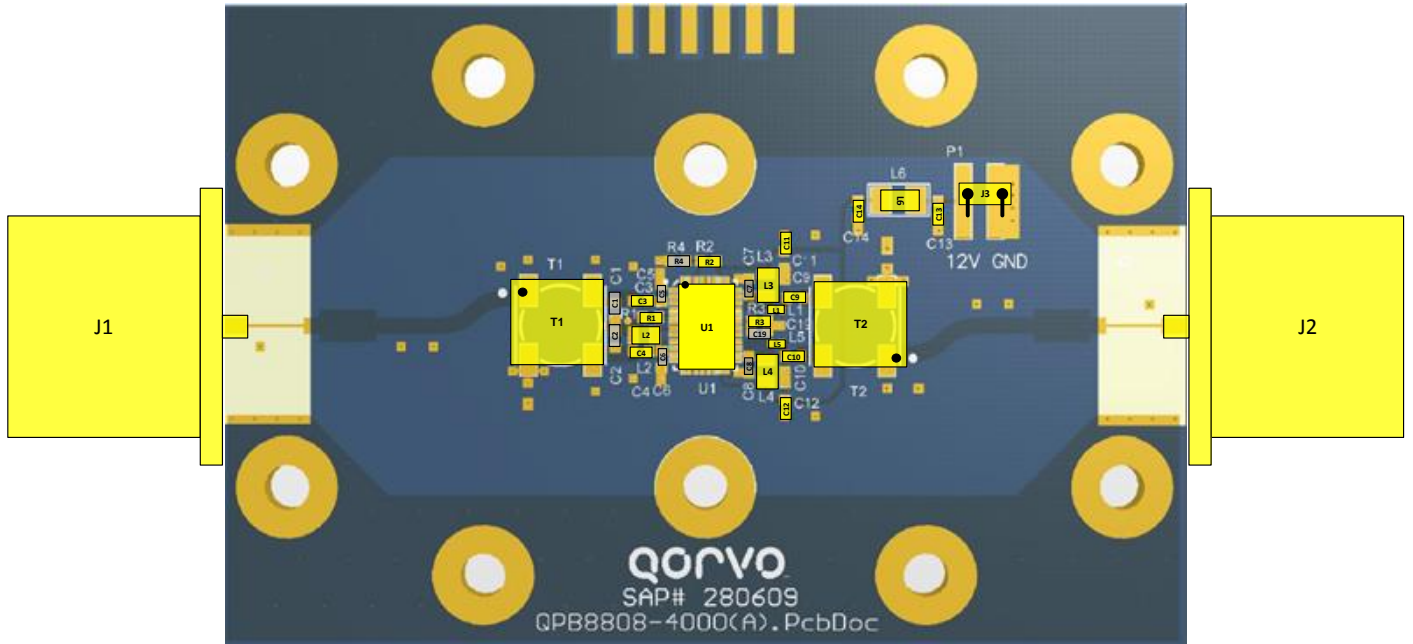

QPB8808PCK401 Evaluation Board

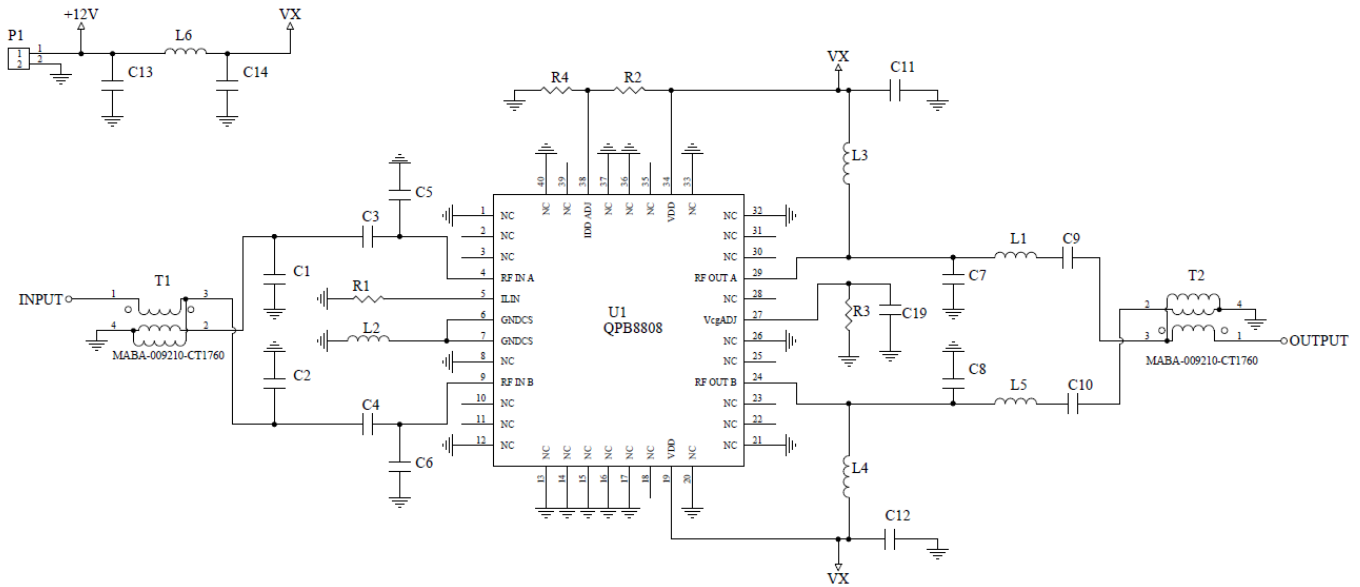

Bill of Materials – QPB8808PCK401

Reference Des.	Value	Description	Manuf.	Part Number
PCB	Rev B	PCB QPB8808 - EVB	Qorvo	–
U1	n/a	QPB8808 Mounted on EVB	Qorvo	QPB8808
U1 – 5 samples	n/a	QPB8808 5 piece of loose samples	Qorvo	QPB8808
T1-2	1:1 BALUN, 75 Ω	MABA-009210-CT1760	MACOM	MABA-009210-CT1760
C11-12	0.01 uF	CAP, 0603, 10%, 50V, X7R	TDK	C1608X7R1H103J
C3-4	1000 pF	CAP, 0603, 5%, 50V, NPO	TDK	C1608NP01H102J080AA
C7-C8	0.5 pF	CAP, 0402, ±0.1pF, 100V, NPO	Murata	GQM1885C2AR50BB01J
C9-10	330 pF	CAP, 0603, 5%, 50V, NPO	TDK	CGJ3E2C0G1H331J080AA
C13-14	0.1 uF	CAP, 0603, 10%, 50V, X7R	TDK	C1608X7R1H104K
L1, L5	1.5 nH	IND, 0402, ±0.1nH, 6GHz SRF, 280mA	Murata	LQP15MN1N5B02D
L2 ¹ , L3, L4	680 nH	IND, 0805, 5%, 355 MHz SRF, 660mA	Coilcraft	0805AF-681XJR
R1	910 Ω	RES, 0603, 5%, 1/16W	Panasonic	ERJ3GEYJ911
R3	1.21 KΩ	RES, 0603, 1%, 1/16W	Panasonic	ERJ3EKF1211V
R2	17.4 KΩ	RES, 0603, 1%, 1/16W	Vishay	CRCW060317K4FKEA
L6	900 nH	IND, 1008, 10%, 1008AF-901X	Coilcraft	022-28-8021
J1-2	75 Ω	N-TYPE MALE, PANEL MOUNT	Pasternack	PE4504
J3	2 pin 0.1" RA	Molex SMT connector	Molex	022-28-8021
R4, C1-2, C5-6, C19	n/a	Do Not Insert	N/A	N/A
PH 4-40	4-40, 0.25",	Pan Head Screw w/ lock washer	various	–
SH 4-40	4-40, 0.25",	Socket Head Screw	various	–
–	Cut to 0.25" x 0.4"	Indium foil 1"x1" x 0.004"	Indium Corp	IND4HSD004
Heatsink	Aluminum	Heatsink for 62 mil board	TriQuint	1094050

Notes:

1. Output source inductor must be rated for 650 mA min for IDD flowing through RF output devices
2. Some N/C pins have been grounded but may be left open

Pin Configuration

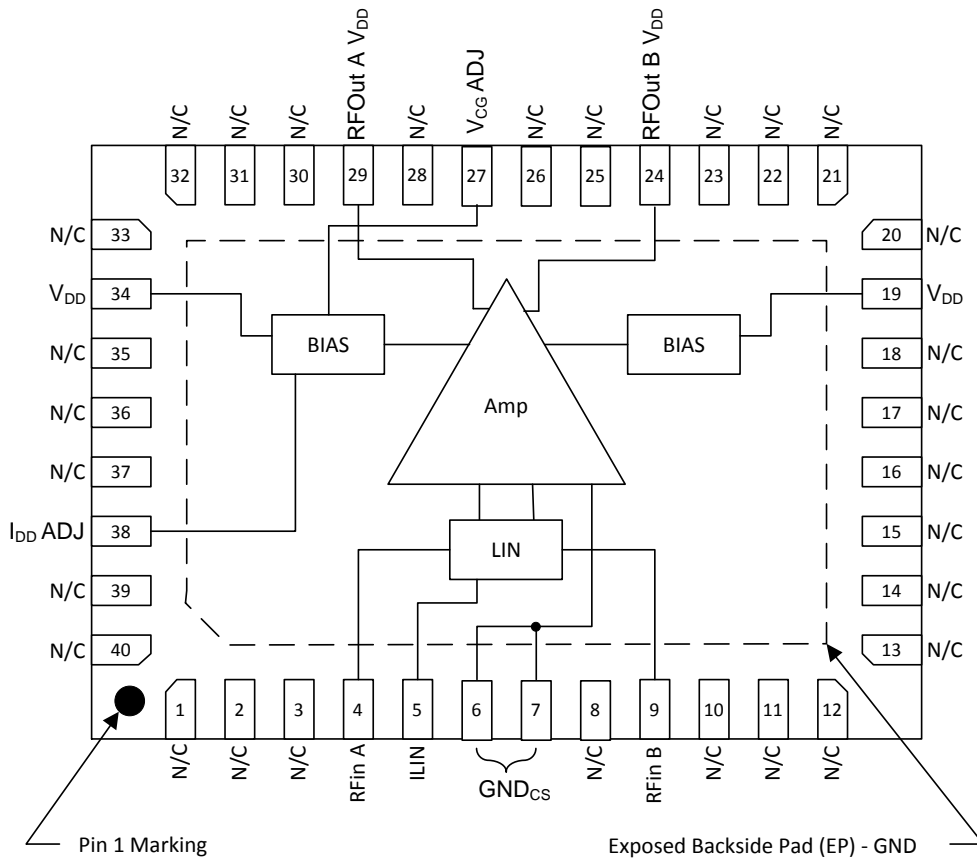

Pin Description

Pin No.	Label	Description
4	RFIn A	RF in A, requires external Balun. External DC Block required.
9	RFIn B	RF in B, requires external Balun. External DC Block required.
5	ILIN	Current adjust pin to optimize Linearity
29	RFout A/V _{DD}	RF Out A and supply voltage, external DC block & Balun required.
24	RFout B/V _{DD}	RF Out B and supply voltage, external DC block & Balun required.
19, 34	V _{DD}	Bias controller supply voltage
27	V _{CG} ADJ	Common Gate adjustment to optimize common gate amplifier bias voltage (normally open)
38	I _{DD} ADJ	I _{DD} current control (normally open), pulling to gnd lowers I _{DD} current
6-7	GND _{CS}	Common Source ground, grounded with inductor. Full DC current flows through this pin, inductor must handle total I _{DD} current.
Backside Paddle	GND	RF/DC ground. Use recommended via pattern to minimize inductance and thermal resistance. See PCB Mounting Pattern for suggested footprint.
1-3, 8, 10-18, 20-23, 25-26, 28, 30-33, 35-37, 39-40	N/C	No connection

Evaluation Board PCB Information

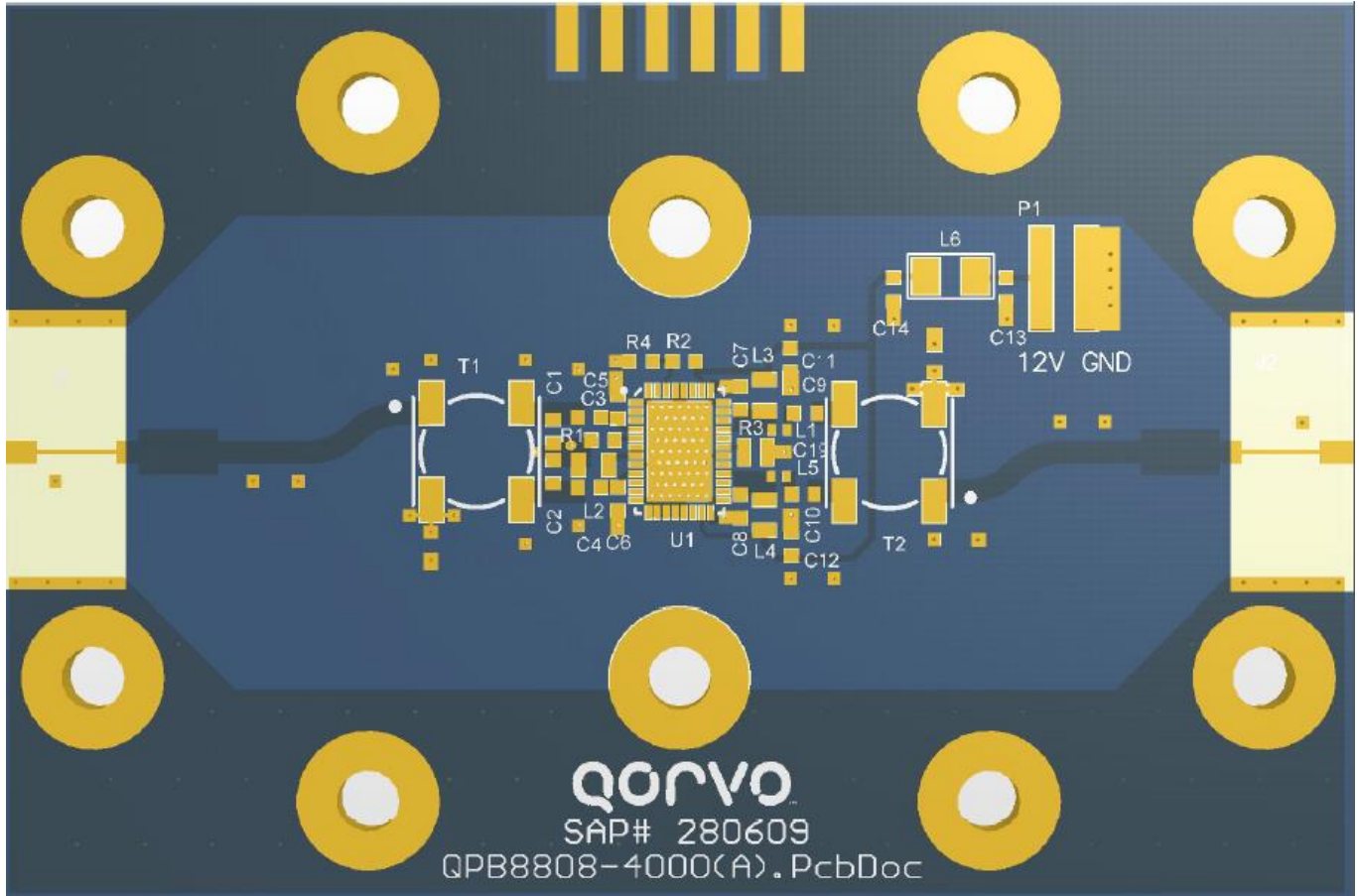

EB & EBP EVB PCB Material and Stack-up

Board Material: 0.062" FR4, $\epsilon_r=4.25$

Plating: 2oz Copper

Board Dimension: 3" x 2"

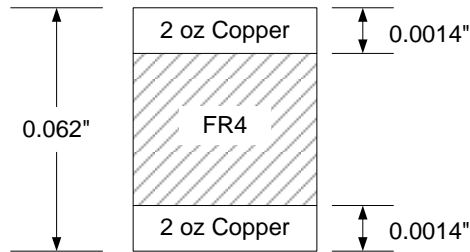

Package Marking and Dimensions

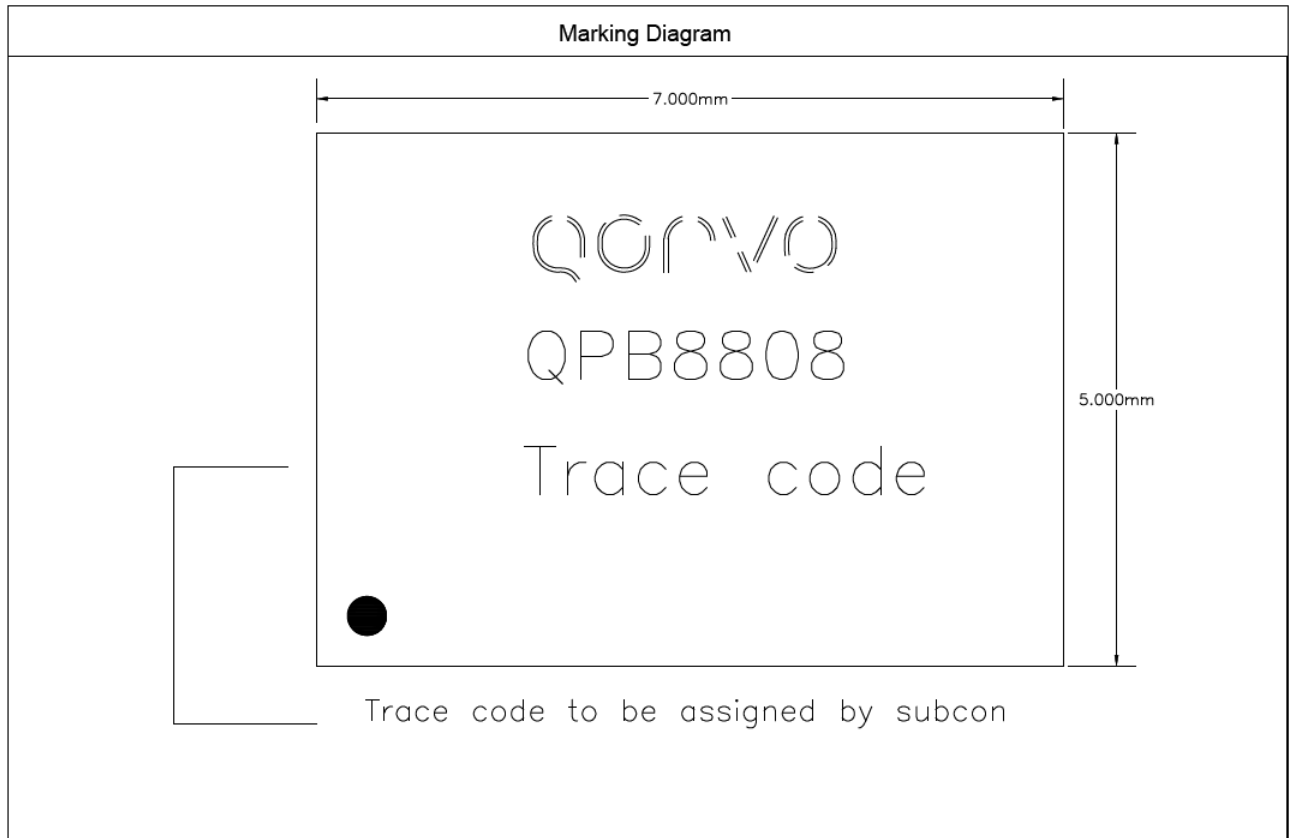

Notes:

1. Dimension and tolerance formats conform to ASME Y14.4M-1994.
2. The terminal #1 identifier and terminal numbering conform to JESD 95-1 SPP-012.
3. Co-planarity applies to the exposed ground/thermal pad as well as the contact pins.
4. Package body length/width does not include plastic flash protrusion across mold parting line.

PCB Mounting Pattern

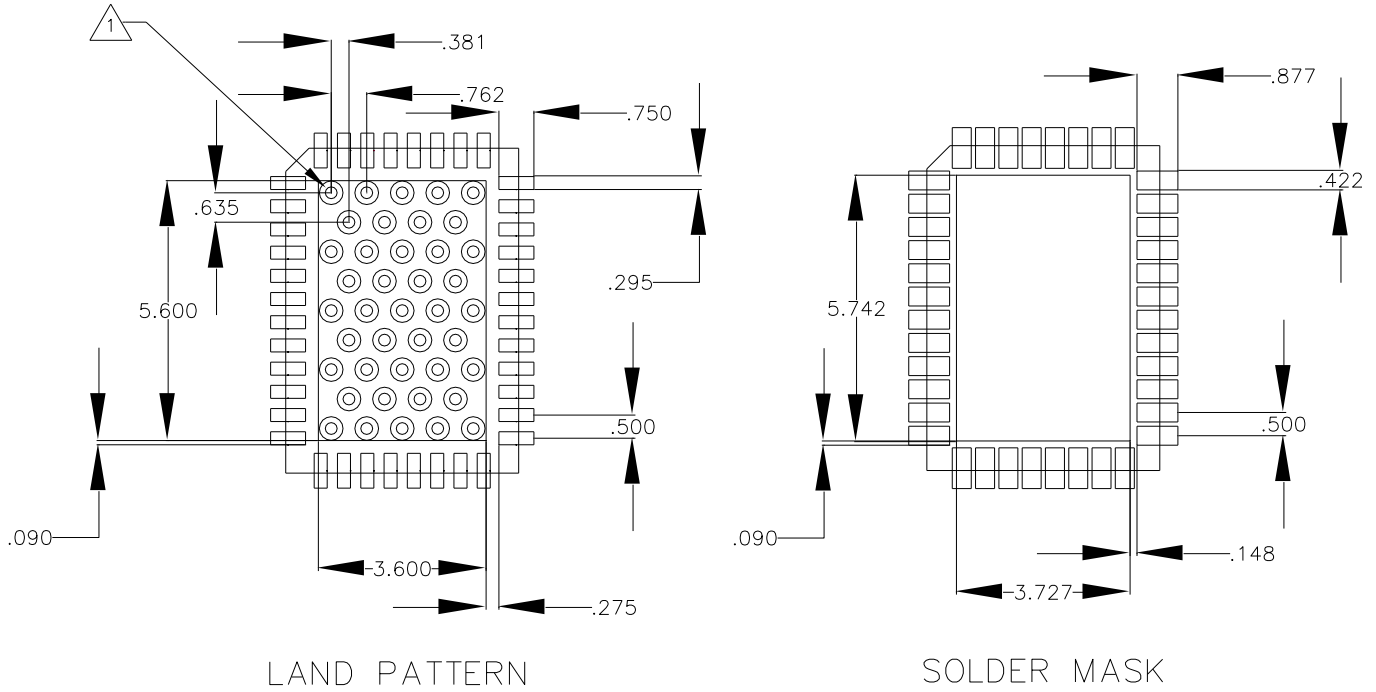

- Notes:
1. All dimensions are in millimeters. Angles are in degrees.
 2. Use 2 oz. copper minimum for top and bottom layer metal.
 3. Vias are required under the backside paddle of this device for proper RF/DC grounding and thermal dissipation. We recommend a 0.35mm (#80/.0135") diameter bit for drilling via holes and a final plated thru diameter of 0.25mm (0.10").
 4. Ensure good package backside paddle solder attach for reliable operation and best electrical performance.
 5. Place mounting screws near the part to fasten a back side heat sink.
 6. Do not apply solder mask to the back side of the PC board in the heat sink contact region.
 7. Ensure that the backside via region makes good physical contact with the heat sink.

Typical Performance Plots

$V_{DD} = +12\text{ V}$, 525 mA, Heatsink Temp. = +35°C, $Z_{In/Out} = 75\ \Omega$ using evaluation board EB, $V_o = 54$ to 57 dBmV at 1218 MHz, 22 dB extrapolated tilt, 79 analog channels plus 111 digital channels (-6 dB offset)

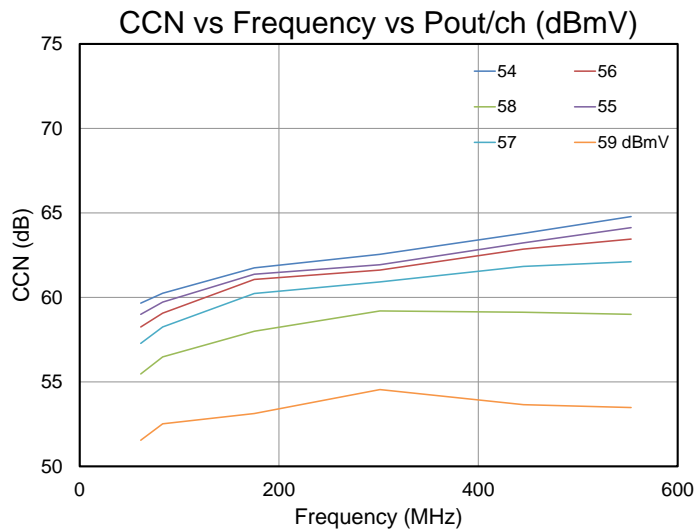
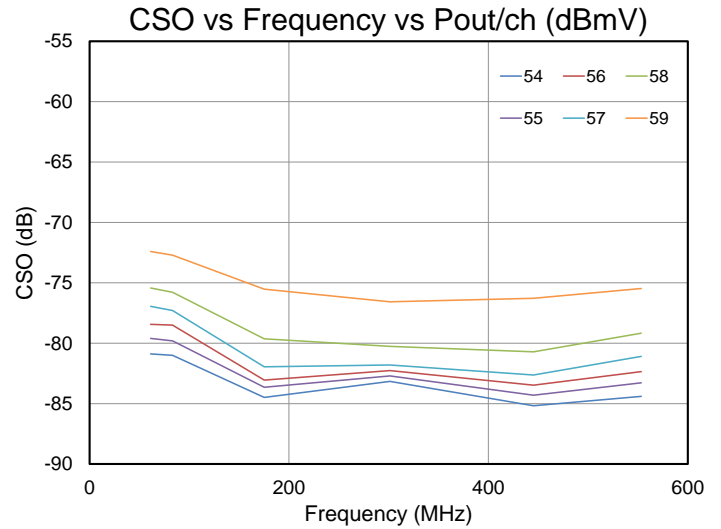
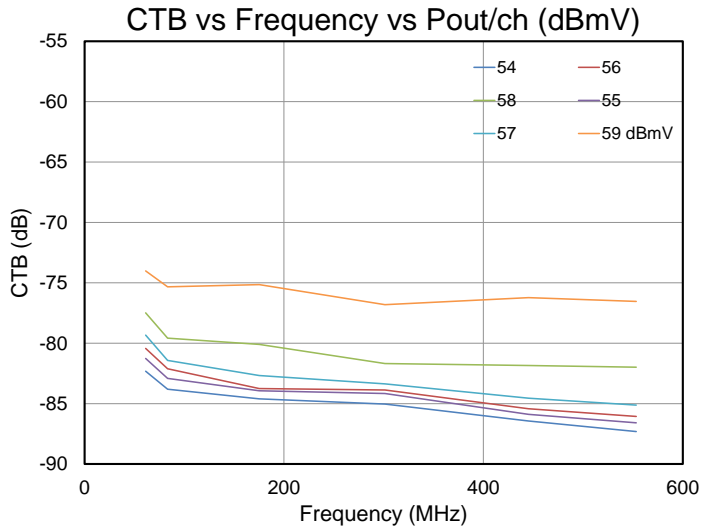

Typical Performance Plots

VDD = +12 V, 525 mA, Heatsink Temp. = +35°C, Z_{In/Out} = 75 Ω using evaluation board EB, Vo = 54 to 57 dBmV at 1218 MHz, 22 dB extrapolated tilt, 79 analog channels plus 111 digital channels (-6 dB offset)

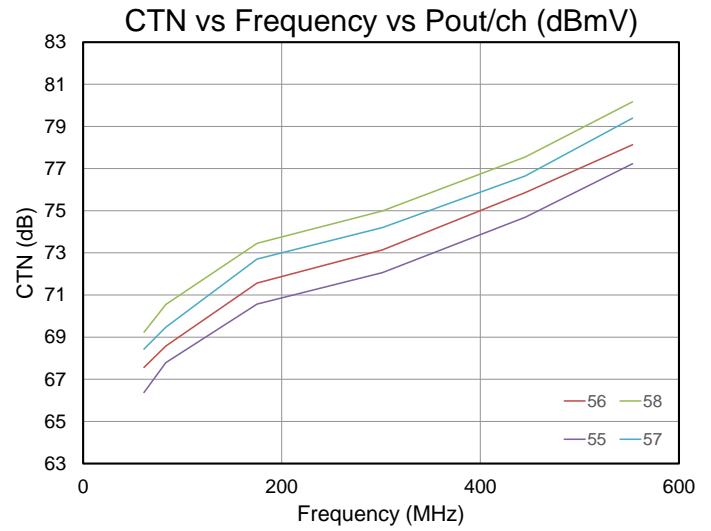
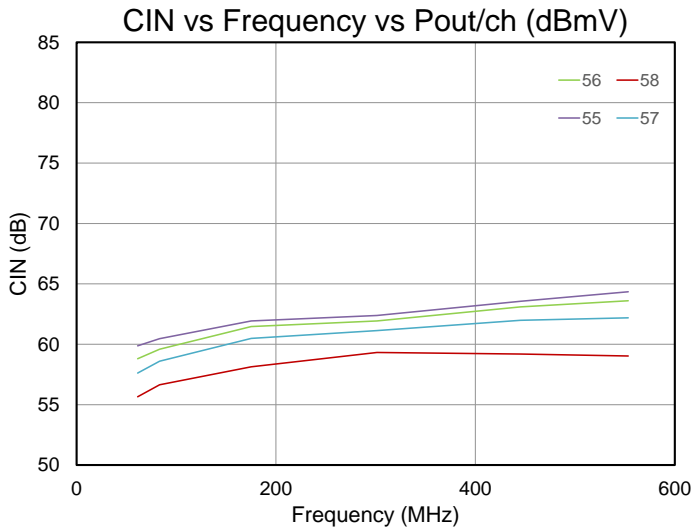

Test conditions unless otherwise noted: V_{DD} = +12 V, 515mA, Heatsink Temp. = +35°C, Z_{In/Out} = 75 Ω using evaluation board EB 261MHz to 1215MHz, 18.6dB tilt, 160 channels Includes input and output balun/transformer losses of tuned application circuit, ITU-T, Annex B, QAM256, 5.36 Msps

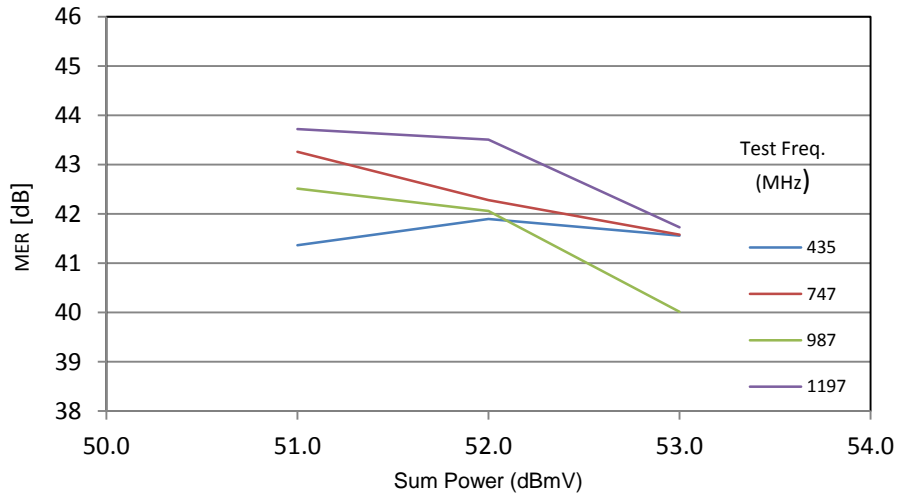

Handling Precautions

Parameter	Rating	Standard
ESD – Human Body Model (HBM)	1A	ANSI/ESD/JEDEC JS-001-2012
ESD – Charged Device Model (CDM)	C1	JEDEC JESD22-C101F
MSL – Moisture Sensitivity Level	Level 3	IPC/JEDEC J-STD-020



Caution!
ESD-Sensitive Device

Solderability

Compatible with both lead-free (260°C max. reflow temp.) and tin/lead (245°C max. reflow temp.) soldering processes. Solder profiles available upon request.

Contact plating: NiPdAu

RoHS Compliance

This part is compliant with 2011/65/EU RoHS directive (Restrictions on the Use of Certain Hazardous Substances in Electrical and Electronic Equipment) as amended by Directive 2015/863/EU.

This product also has the following attributes:

- Lead Free
- Halogen Free (Chlorine, Bromine)
- Antimony Free
- TBBP-A (C₁₅H₁₂Br₄O₂) Free
- PFOS Free
- SVHC Free



Contact Information

For the latest specifications, additional product information, worldwide sales and distribution locations:

Web: www.qorvo.com

Tel: 1-844-890-8163

Email: customer.support@qorvo.com

Important Notice

The information contained herein is believed to be reliable; however, Qorvo makes no warranties regarding the information contained herein and assumes no responsibility or liability whatsoever for the use of the information contained herein. All information contained herein is subject to change without notice. Customers should obtain and verify the latest relevant information before placing orders for Qorvo products. The information contained herein or any use of such information does not grant, explicitly or implicitly, to any party any patent rights, licenses, or any other intellectual property rights, whether with regard to such information itself or anything described by such information. **THIS INFORMATION DOES NOT CONSTITUTE A WARRANTY WITH RESPECT TO THE PRODUCTS DESCRIBED HEREIN, AND QORVO HEREBY DISCLAIMS ANY AND ALL WARRANTIES WITH RESPECT TO SUCH PRODUCTS WHETHER EXPRESS OR IMPLIED BY LAW, COURSE OF DEALING, COURSE OF PERFORMANCE, USAGE OF TRADE OR OTHERWISE, INCLUDING THE IMPLIED WARRANTIES OF MERCHANTABILITY AND FITNESS FOR A PARTICULAR PURPOSE.**

Without limiting the generality of the foregoing, Qorvo products are not warranted or authorized for use as critical components in medical, life-saving, or life-sustaining applications, or other applications where a failure would reasonably be expected to cause severe personal injury or death.

Copyright 2016 © Qorvo, Inc. | Qorvo is a registered trademark of Qorvo, Inc.