

Member of the **maxVZ** Family

**Benefits**

- One part for different input and output voltage ranges
- One part with up to 17A output
- Reduces number of different parts in inventory
- Compatible with conventional pick-and-place equipment

**Features**

- Extra-wide input low voltage range: 3.0V – 13.2V
- Wide-range programmable output: 0.7V – 3.63V
- Remote voltage sense
- High continuous output current: 17A
- High current density: 44 A/in<sup>2</sup>
- Efficiency up to 95%
- No minimum load required
- Output short circuit protection
- Start-up into prebiased output
- Full current sink capability for active bus termination
- Remote enable (ON/OFF)
- Wide operating temperature range
- UL60950 recognized, CSA C22.2 No. 60950-00 certified, and TUV EN60950-1:2001 certified

**Applications**

- Low voltage, high density power systems with Intermediate Bus Architectures (IBA) from 3.0V to 13.2V
- Servers, desktops, and portable computing
- Broadband, networking, optical, and communications systems
- Battery-operated equipment
- Point-of-load regulation for high performance DSP, FPGA, ASIC, and microprocessors
- Advanced set-top boxes
- Memory bus terminators

**Description**

The Y5117 is a series of highly efficient point-of-load DC/DC power converters in a unique SIP style surface mount package, designed to deliver low voltages at high currents in close proximity to loads. Extra-wide input voltage range, programmable output voltage, and fast transient response are just a few of the integrated features that minimize power system cost and time to market. Power-One's point-of-load converters are recommended for use with regulated bus converters in an Intermediate Bus Architecture (IBA).

**Selection Chart**

Model	Input Voltage, VDC	Input UVLO, VDC	Output Voltage, VDC	Output Current, ADC
Y5117P	3.0 – 13.2	3.8	0.7 – 3.63	17
Y5117PC	3.0 – 13.2	4.5	0.7 – 3.63	17

Model numbers highlighted in yellow or shaded are not recommended for new designs.

**Ordering Information**

Part Number	Description	Quantity of Y5117XX
Y5117XX-T1	Tape and Reel	500
Y5117XX-T2	Tape and Reel	100
Y5117XX-K1	Evaluation Kit	1 mechanical sample and eval board
Y5117XX-K5	Sample Kit	5 functional samples

### 1. Absolute Maximum Ratings

Stresses in excess of the absolute maximum ratings may cause performance degradation, adversely affect long-term reliability, and cause permanent damage to the converter

Parameter	Conditions/Description	Min	Max	Units
Operating Temperature Range	Measured on case (T <sub>CASE</sub> )	-40	110	°C
Storage Temperature (T <sub>S</sub> )		-55	125	°C
Output Current			17	ADC
Input Voltage	V <sub>IN</sub> referenced to P <sub>gnd</sub>	-0.3	15	VDC

### 2. Environmental and Mechanical Specifications

Parameter	Conditions/Description	Min	Nom	Max	Units
Sinusoidal Vibration	JESD-B103-B			20	g
Weight				5	grams
Ambient Temperature Range		-40		85	°C
Storage Temperature (T <sub>S</sub> )		-55		125	°C
MTBF	Calculated Per Telcordia Technologies SR-332	3,020			kHrs

### 3. Electrical Specifications

Refer to the evaluation board described in Appendix A. Specifications apply over specified input voltage, output load and operating temperature, unless otherwise noted.

#### 3.1 Input Specifications

Parameter	Conditions/Description	Min	Nom	Max	Units
Input voltage (V <sub>IN</sub> )	At V <sub>IN</sub> <5.2V, V <sub>LDO</sub> pin needs to be connected to an external voltage source ≥5.2V	3.0		13.2	VDC
Input Current	V <sub>IN</sub> NOM, I <sub>OUT</sub> = 0A, enable high		40	50	mADC
Undervoltage Lockout (UVLO)	Ramping Up				
	V <sub>IN</sub> <5.2V, V <sub>LDO</sub> connected to V <sub>EXT</sub> =5.2V, 10k resistor between Enable and P <sub>gnd</sub>		2.75		VDC
Y5117P	V <sub>IN</sub> ≥5.2V, V <sub>LDO</sub> connected to V <sub>IN</sub>		3.8		VDC
Y5117PC	V <sub>IN</sub> ≥5.2V, V <sub>LDO</sub> connected to V <sub>IN</sub>		4.5		VDC
UVLO Hysteresis			100		mVDC

### 3.2 Output Specifications

Parameter	Conditions/Description	Min	Nom	Max	Units
Output Voltage Range ( $V_{OUT}$ )	$V_{OUT} < 0.7V_{IN}$	0.7	1.3	3.63	VDC
Output Voltage Setpoint Accuracy	Trim resistors <0.1% tolerance $V_{OUT} > 1.3V$ $V_{OUT} < 1.3V$ (using internal reference)	-1.2 -4.8		1.2 4.8	% $V_{OUT}$ % $V_{OUT}$
Output Current ( $I_{OUT}$ )	$V_{IN MIN}$ to $V_{IN MAX}$	0		17	A
Line Regulation	$V_{IN MIN}$ to $V_{IN MAX}$			±0.5	% $V_{OUT}$
Load Regulation	$I_{OUT MIN}$ to $I_{OUT MAX}$			±0.5	% $V_{OUT}$
Turn-On Time (when input voltage is applied)	To Output Regulation Band Rise Time (10% to 90%)		11 5		ms ms
Turn-On Time (turn-on via Enable pin)	To Output Regulation Band		15		ms
Dynamic Regulation Peak Deviation Settling Time	$V_{IN}=13.2V$ , $2.5A/\mu s$ , $C_{OUT}=1,360\mu F$ 25–75% load step change to 1% error band		5 200		% $V_{OUT}$ $\mu s$
Output Voltage Ripple & Noise	$V_{IN MIN}$ to $V_{IN MAX}$ , $I_{OUT MIN}$ to $I_{OUT MAX}$ BW=20MHz		25	60	mV p-p
Admissible Load Capacitance	$V_{IN MIN}$ to $V_{IN MAX}$ , $I_{OUT MIN}$ to $I_{OUT MAX}$	5,000			$\mu F$
Switching Frequency			510		kHz
Temperature Coefficient				0.02	% $V_{OUT}/^{\circ}C$

### 3.3 Protection Specifications

Parameter	Conditions/Description	Min	Nom	Max	Units
<b>Output Overcurrent Protection</b>					
Protection Type			Non-Latching		
Output Current Limit Threshold	$V_{IN MIN}$ to $V_{IN MAX}$	18.7	22	27	ADC

### 3.4 Feature Specifications

Parameter	Conditions/Description	Min	Nom	Max	Units
<b>Enable</b>					
$V_{ENABLE}$ turn-on threshold Open Circuit Voltage Converter OFF Source Current	$V_{IN MIN}$ to $V_{IN MAX}$ Enable pin is floating $V_{on/off}$ is referenced to P <sub>gnd</sub> Enable pin is connected to P <sub>gnd</sub>		1.4	$V_{IN}$ 0.55 1.5	VDC VDC VDC mADC
<b>Output Voltage Trim</b>					
Default Output Voltage	No trim resistor		1.3		VDC
Trim Range	$V_{IN MIN}$ to $V_{IN MAX}$ , $I_{OUT MIN}$ to $I_{OUT MAX}$	0.7		3.63	VDC
<b>Remote Sense</b>					
Voltage Drop Compensation	$V_{IN MIN}$ to $V_{IN MAX}$ , $I_{OUT MIN}$ to $I_{OUT MAX}$			100	mVDC

**4. Typical Performance Characteristics**

**4.1 Efficiency Curves (at room temperature)**

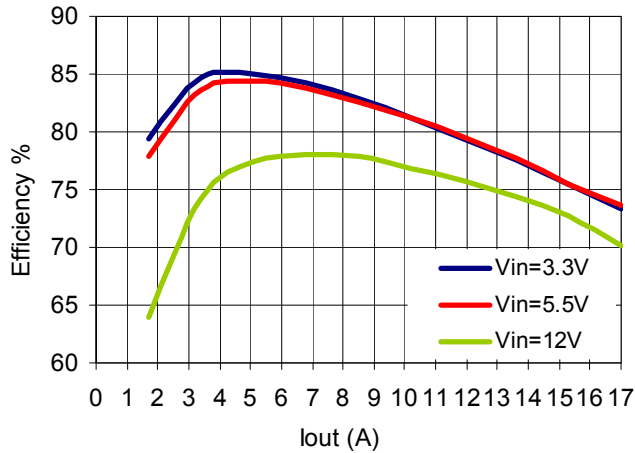

**Figure 1. Efficiency Vs. Load at Vout=0.7V**

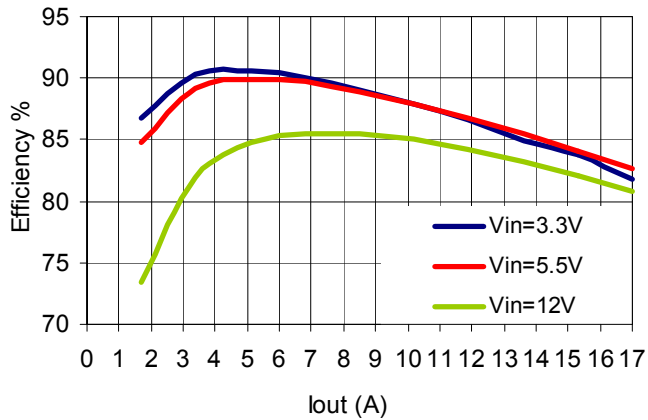

**Figure 2. Efficiency Vs. Load at Vout=1.3V**

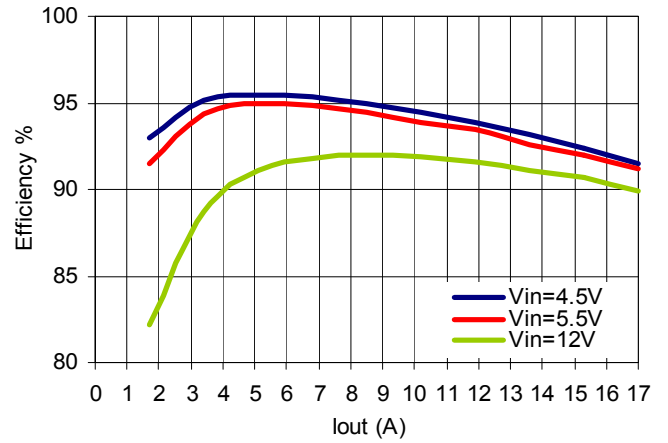

**Figure 3. Efficiency Vs. Load at Vout=3.3V**

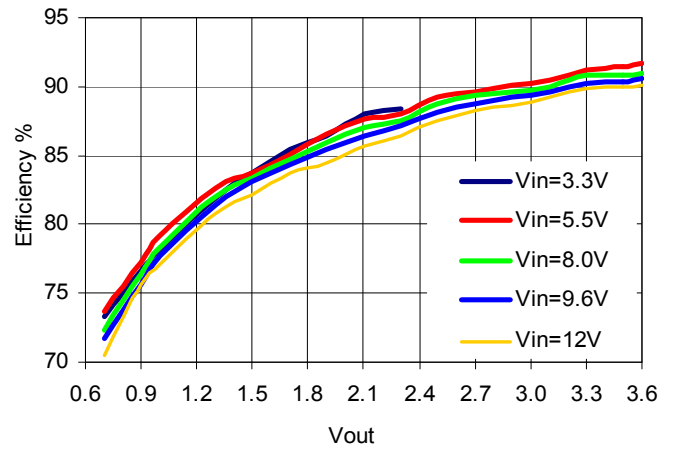

**Figure 4. Efficiency Vs. Output Voltage at Iout=17A and Different Input Voltages**

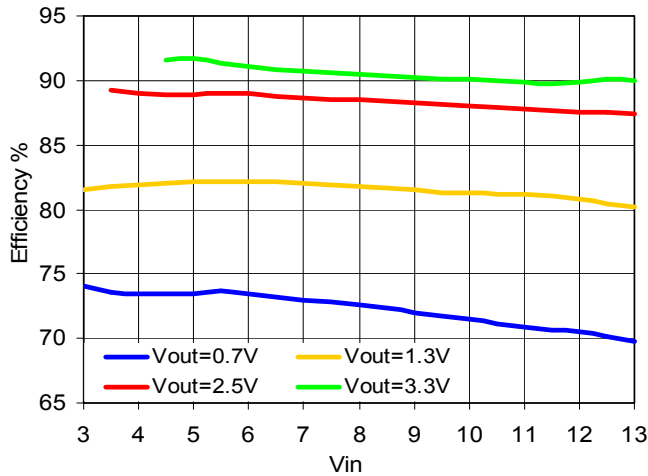

Figure 5. Efficiency Vs. Input Voltage at Iout=17A and Different Output Voltages

4.2 Y5117P Turn-On Characteristics

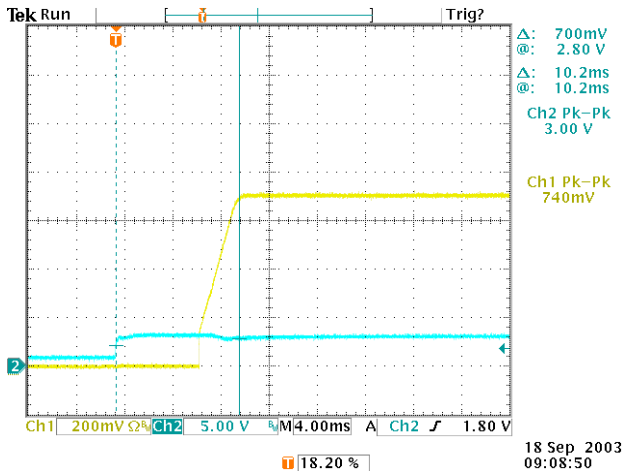

Figure 6. Vin=3.0V, Vout=0.7V, Iout=8.5A. Ch1 – Vout, Ch2 – Vin

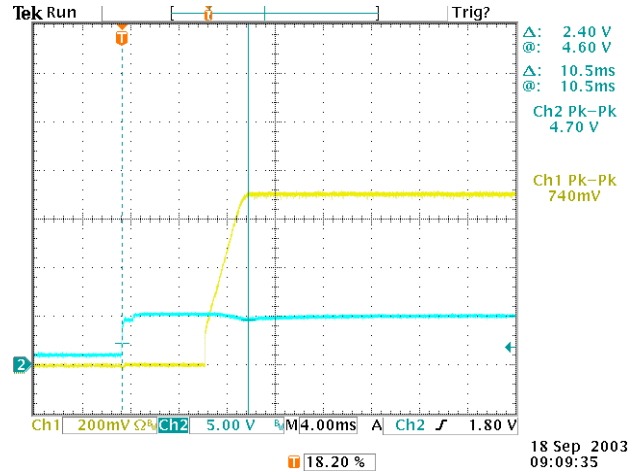

Figure 7. Vin=5V, Vout=0.7V, Iout=8.5A. Ch1 – Vout, Ch2 – Vin

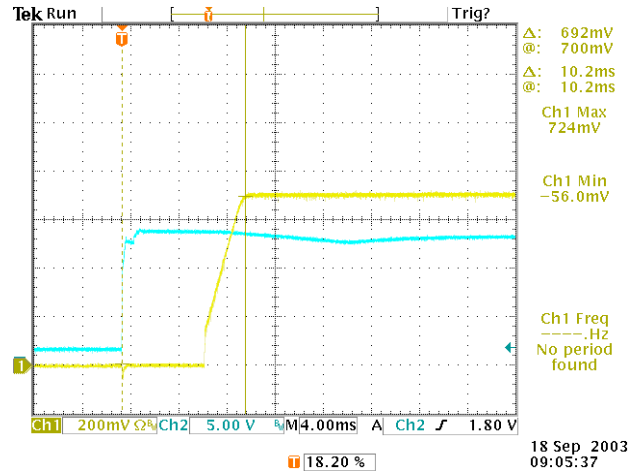

Figure 8. Vin=13.2V, Vout=0.7V, Iout=8.5A. Ch1 – Vout, Ch2 – Vin

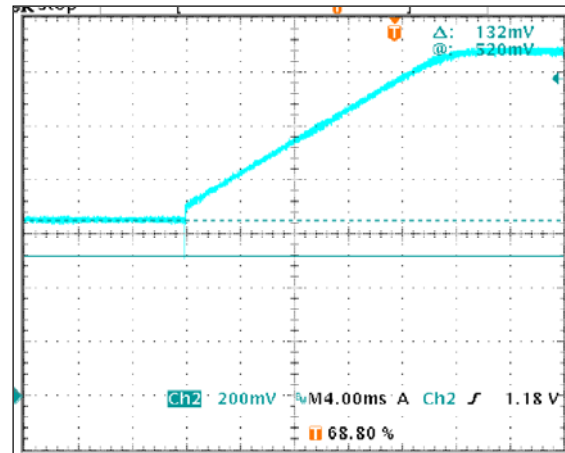

Figure 9. Turn-on into the output prebiased to 50% of Vout. Vin=5V, Vout=1.3V, Iout=17A. Ch1 – Vout

**4.3 Thermal Derating Curves**

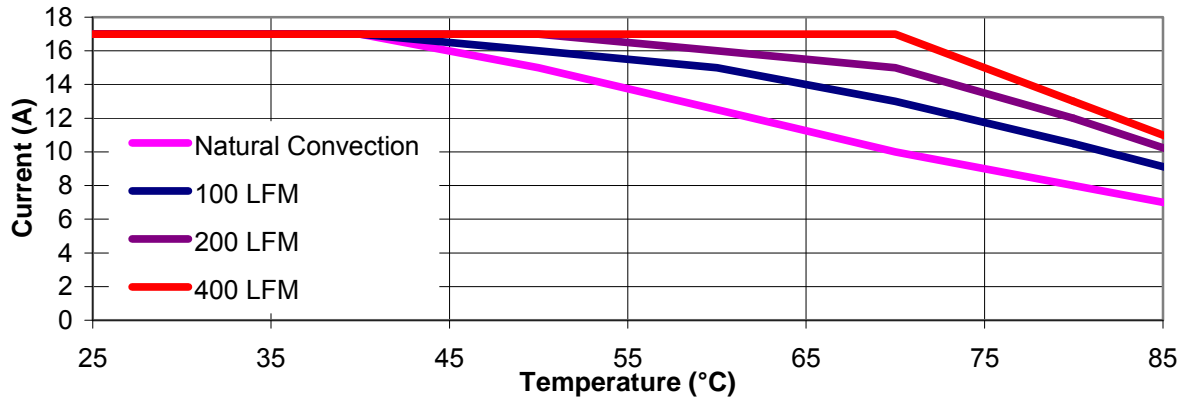

Figure 10. Thermal Derating Curves for the Worst Case Operating Conditions: Vin=13.2V, Vout=3.3V

5. Typical Applications Schematics

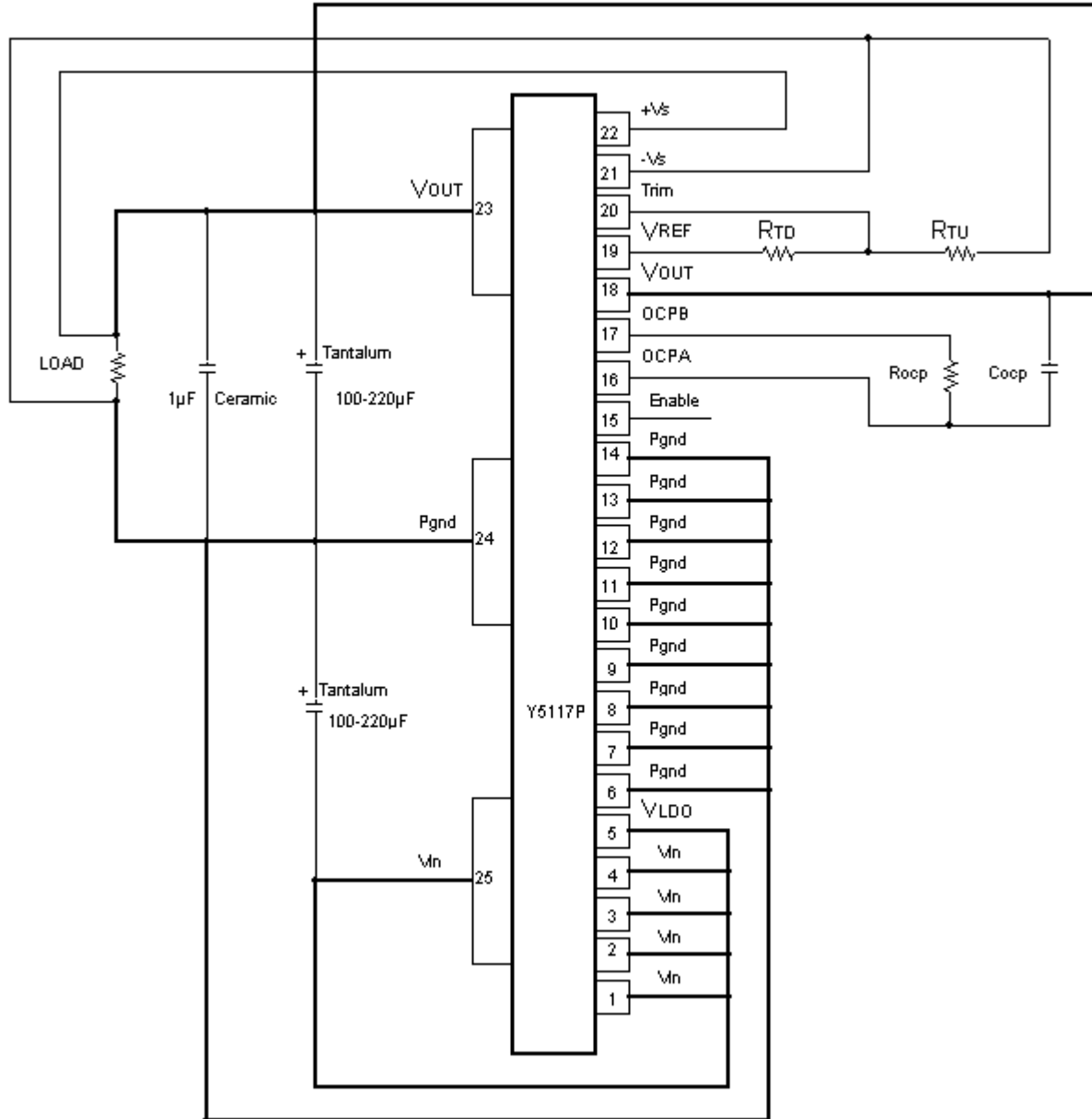

Figure 11. Typical Application Circuit for  $V_{in} \geq 5.2VDC$ .  $V_{LDO}$  is connected to  $V_{in}$

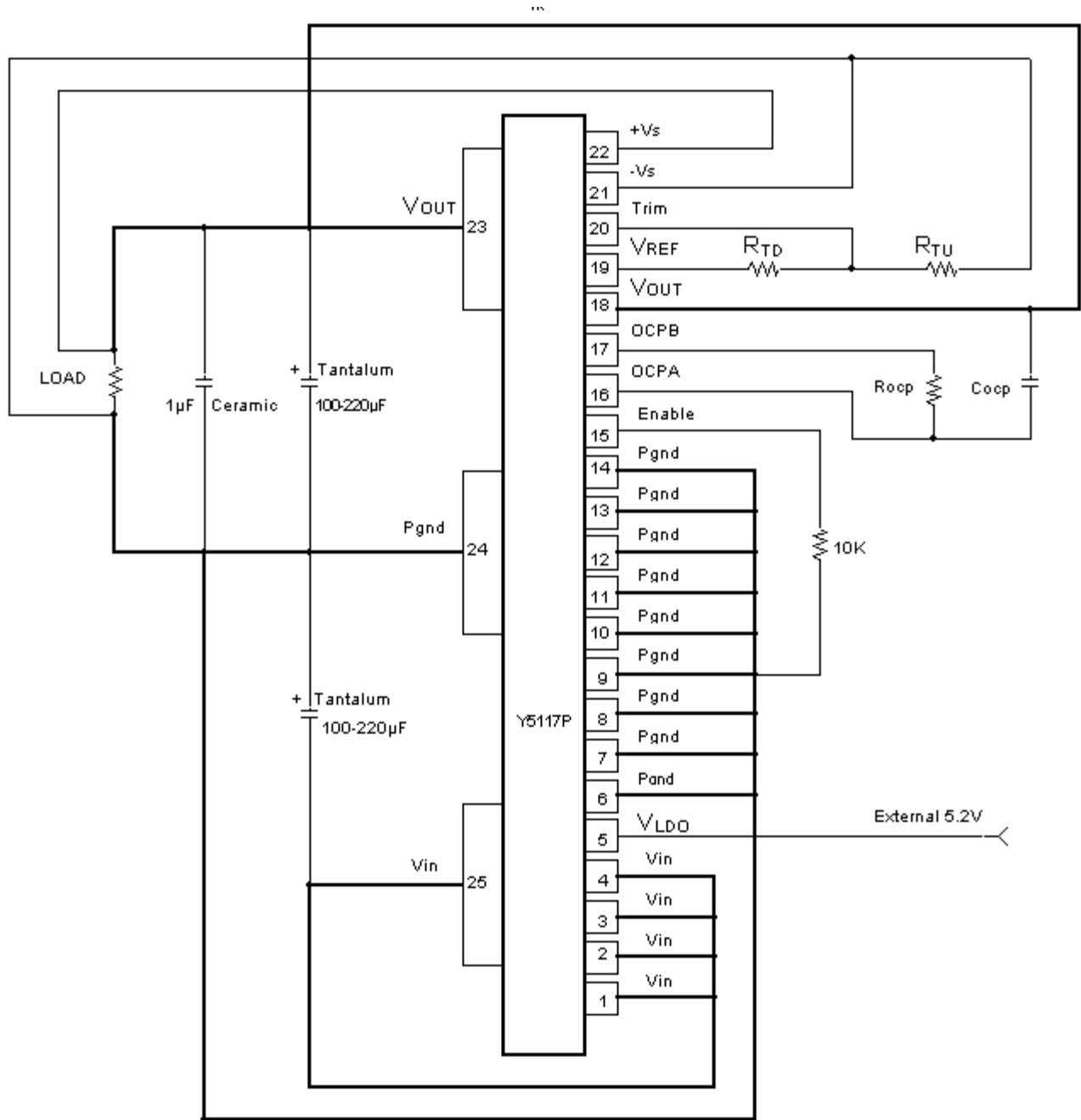

Figure 12. Typical Application Circuit for  $5.2\text{VDC} > V_{in} \geq 3.0\text{VDC}$ .  $V_{LDO}$  is connected to the external voltage source. 10kOhm resistor is placed between the Enable pin and Pnd.



## 6. Feature Description

### 6.1 Enable

This function allows the converter to be turned on or off remotely. The Enable pin is internally pulled up to the input voltage. It is recommended to control the Enable pin with an open collector transistor. The saturation voltage of the transistor shall be less than 0.55V at 1mA to reliably turn the converter OFF.

The Enable pin of Y5117P can be left floating, if not used. The Enable pin of Y5117PC shall be pulled low until the input voltage reaches 6V.

### 6.2 Internal Supply Voltage ( $V_{LDO}$ )

If the input voltage is lower than 5.2V, then the  $V_{LDO}$  pin is required to be connected to an external voltage source ( $\geq 5.2V$ ). This voltage should not exceed 15V and be capable of supplying 60mA.

### 6.3 Undervoltage Lockout

The undervoltage lockout scheme monitors the input voltage applied to it and does not allow the converter to start when  $V_{IN}$  is less than the UVLO threshold.

When the input voltage is higher than 5.2V, the  $V_{LDO}$  pin is connected to the input voltage. When the input voltage is below 5.2V, the  $V_{LDO}$  pin is connected to an external voltage source. UVLO turn-on threshold is then set with the 10kOhm resistor connected between the Enable pin and the ground as shown in Figure 12.

### 6.4 Output Voltage Trim

The output voltage is preset to 1.3V. The trim feature allows the user to adjust the output voltage from this nominal value.

**Increase  $V_{OUT}$ :** Trim range  $1.3V < V_{OUT} \leq 3.63V$ . An external resistor ( $R_{TU}$ ) is placed between the Trim pin and the  $-Vs$  (negative voltage sense) pin.

$$R_{TU} = 137.5 / (V_{OUT} - 1.3), \text{ k}\Omega$$

**Decrease  $V_{OUT}$ :** Trim range  $0.7V \leq V_{OUT} < 1.3V$ .

An external resistor ( $R_{TD}$ ) is placed between Trim pin and  $V_{REF}$  pin.

$$R_{TD} = 110(V_{REF} - 1.25) / (1.3 - V_{OUT}), \text{ k}\Omega$$

Note that  $V_{OUT}$  cannot exceed  $0.7V_{IN}$ .

An internal 5V (+/-2.5%) reference voltage is available from  $V_{REF}$  (pin 19). Alternatively, an external

reference voltage can be used for better accuracy (typically 1%). The external reference voltage should be in the range from 1.26V to 5.5V and capable of supplying 1mA.

Table 1. Sample Trim Resistance Values

$V_{OUT}$ (V)	$R_{TD}$ (k $\Omega$ )	$R_{TU}$ (k $\Omega$ )
0.7	686.36, ( $V_{REF} = 5V$ )	
1.0	1370, ( $V_{REF} = 5V$ )	
1.25	8088, ( $V_{REF} = 5V$ )	
1.3	----- None – factory default -----	
1.5		690.95
2.5		114.68
3.3		68.78

### 6.5 Output Current Limit

When the output load exceeds the current limit threshold, the converter will enter a low power hiccup mode. Once the overcurrent is removed, the output voltage will recover automatically.

### 6.6 Output Current Limit Adjustment

The OCP adjustment function allows greater flexibility to set the output current limit inception point ( $I_{LIM}$ ), from default of 22A to a minimum of 14.8A using an external resistor and a capacitor. To adjust the  $I_{LIM}$ , place the resistor  $R_{OCP}$  between OCPA and OCPB pins, and the capacitor  $C_{OCP}$  between OCPA and Vout pins. Do not short OCPA directly to OCPB.

To calculate  $R_{OCP}$  and  $C_{OCP}$ , use the equations below:

$$R_{OCP} = 10(I_{LIM} - 12.6) / (22.8 - I_{LIM}), \text{ k}\Omega$$

$$C_{OCP} = 414.4 / R_{OCP} - 26, \text{ nF},$$

where  $R_{OCP}$  is on k $\Omega$

Table 2. Sample Standard Values for  $R_{OCP}$  and  $C_{OCP}$

$I_{LIM}$	$R_{OCP}$	$C_{OCP}$
~22A	Open	None
~20A	26.7k $\Omega$	None
~17A	7.5k $\Omega$	27nF
~13.5A	1k $\Omega$	390nF

### **6.7 Remote Voltage Sense**

This feature provides improved load regulation by compensating for the voltage drop between the output of the converter and the load.

## 7. Pinout

Pin	Function	Name
1	Input Voltage	V <sub>IN</sub>
2	Input Voltage	V <sub>IN</sub>
3	Input Voltage	V <sub>IN</sub>
4	Input Voltage	V <sub>IN</sub>
5	Internal Supply Voltage	V <sub>LDO</sub>
6	Power Ground	Pgnd
7	Power Ground	Pgnd
8	Power Ground	Pgnd
9	Power Ground	Pgnd
10	Power Ground	Pgnd
11	Power Ground	Pgnd
12	Power Ground	Pgnd
13	Power Ground	Pgnd
14	Power Ground	Pgnd
15	ON/OFF Control	Enable
16	Output Current Limit Adjust	OCPA
17	Output Current Limit Adjust	OCPB
18	Output Voltage	V <sub>OUT</sub>
19	Reference Voltage (Internal)	V <sub>REF</sub>
20	Output Voltage Adjust	Trim
21	Negative Voltage Sense	-V <sub>S</sub>
22	Positive Voltage Sense	+V <sub>S</sub>
23	Output Voltage	V <sub>OUT</sub>
24	Power Ground	Pgnd
25	Input Voltage	V <sub>IN</sub>

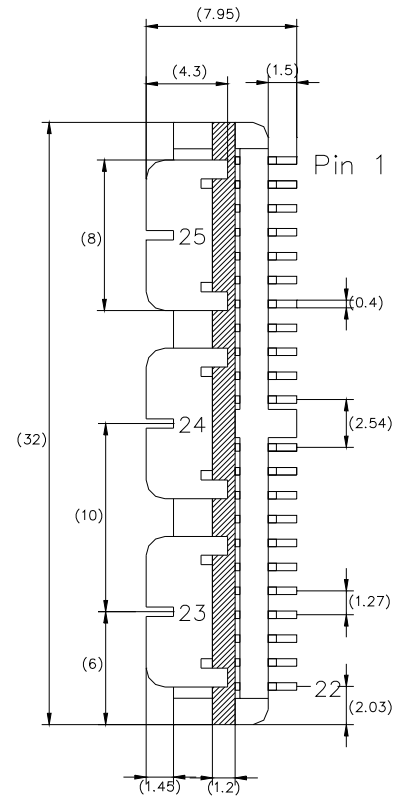

BOTTOM VIEW (Pin-out)

## 8. Pin Functions

**V<sub>in</sub> (Pin 1 – 4, 25):** Input Voltage, 3 – 13.2V.

**Pgnd (Pin 6-14, 24):** Power Ground.

**+V<sub>S</sub> (Pin 22):** Positive Sense Lead. Connect to the positive point close to the load.

**-V<sub>S</sub> (Pin 21):** Negative Voltage Sense lead. Connect to the negative point close to the load.

**Trim (Pin 20):** Output voltage trim. With no connection the output voltage is set to 1.3 V.

**V<sub>REF</sub> (Pin 19):** Internal reference voltage, 5V, output can be used to generate outputs <1.3V.

**Enable (Pin 15):** Enable input. Internally pulled to V<sub>in</sub>. When left floating, the converter is enabled (ON). With enable connected to the ground or pulled low the converter is disabled (OFF).

**OCPA and OCPB (Pins 16, 17):** Output Current Limit Adjustment, using a resistor and a capacitor.

**V<sub>OUT</sub> (Pin 18, 23):** Output Voltage. Use pin 23 for high current connection to the load, pin 18 for OCP adjustment.

**V<sub>LDO</sub> (Pin 5):** Internal supply voltage. Connect to an external voltage source >5.2V, if the input voltage is below 5.2V.

**9. Mechanical Drawings**

All Dimensions are in mm

Tolerances:

0.5-10 ±0.1

10-100 ±0.2

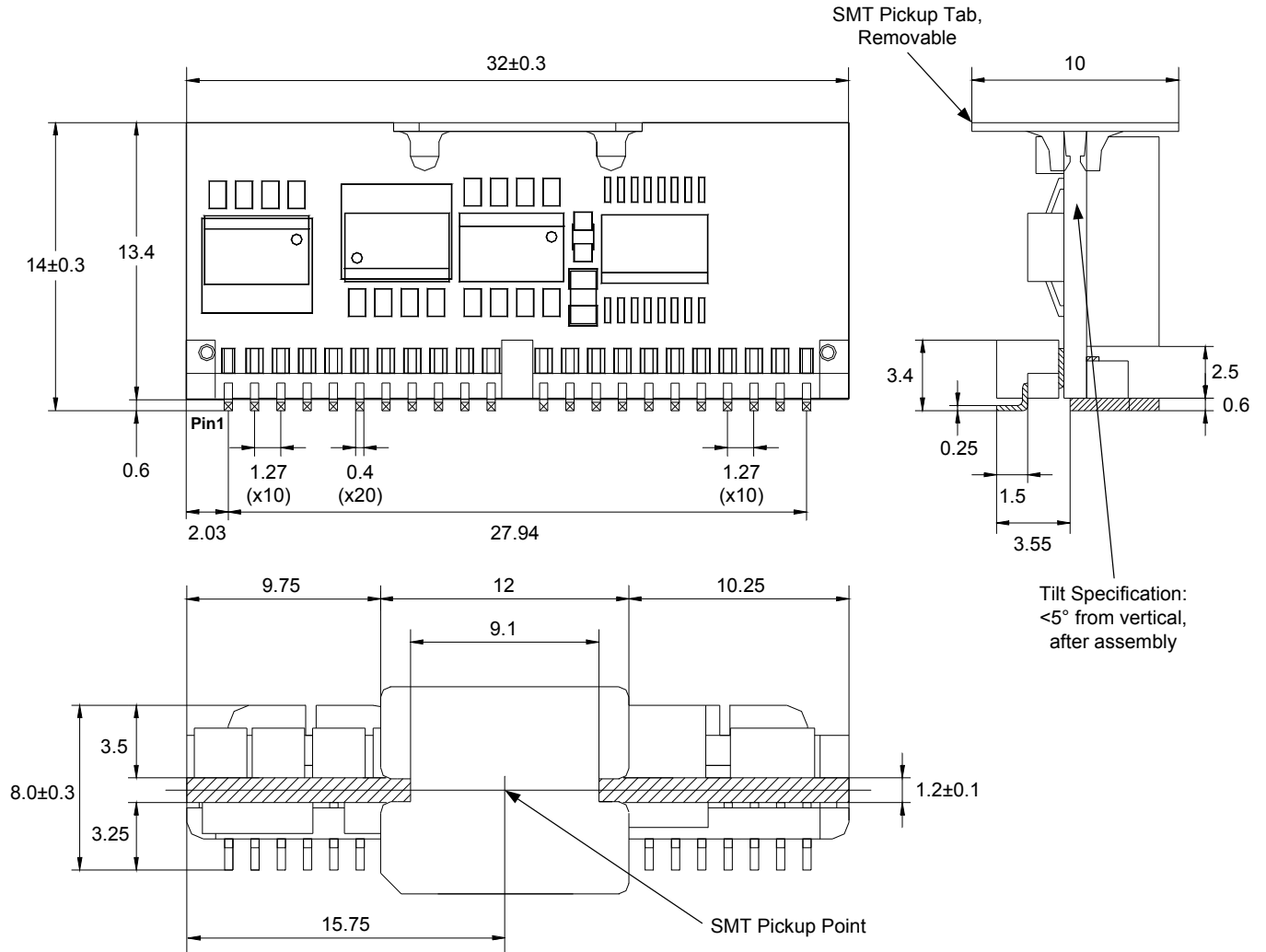

**Figure 13. Mechanical Drawing**

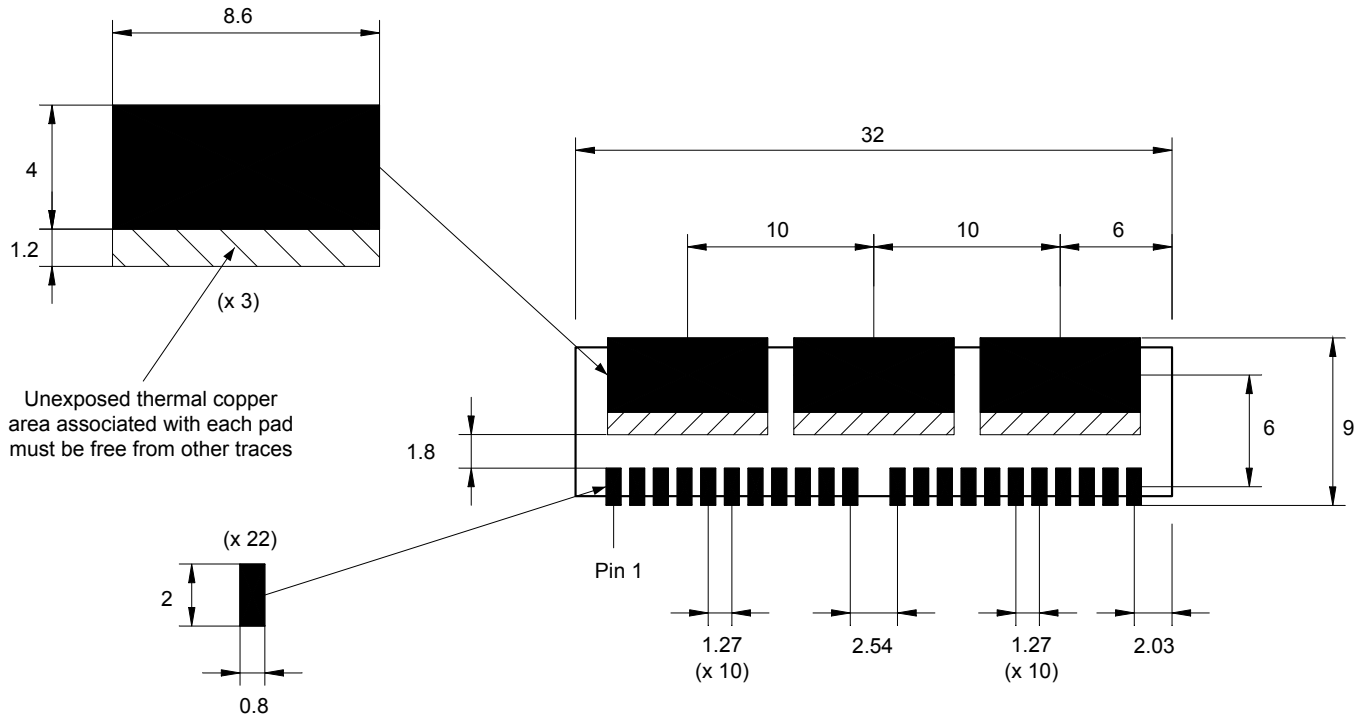

**Figure 14. Recommended Pad Sizes**

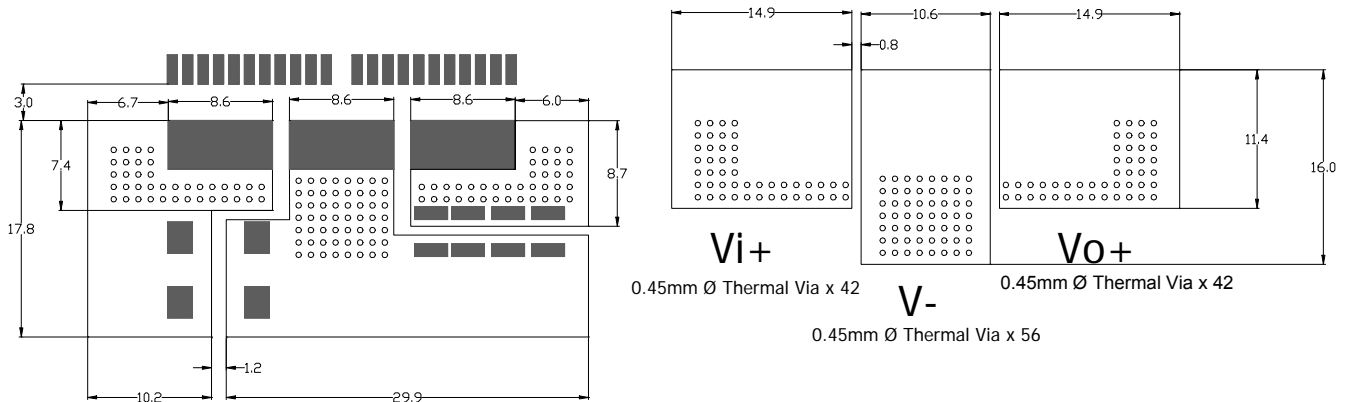

**Figure 15. Recommended PCB Layout for Multilayer PCBs**

**Notes:**

1. NUCLEAR AND MEDICAL APPLICATIONS - Power-One products are not designed, intended for use in, or authorized for use as critical components in life support systems, equipment used in hazardous environments, or nuclear control systems without the express written consent of the respective divisional president of Power-One, Inc



**Y5117 17A DC-DC POL Data Sheet**  
**3.0V to 13.2V Input • 0.7V to 3.63V Output**

---

2. TECHNICAL REVISIONS - Specifications are subject to change without notice.

**APPENDIX A.**

**Setup and use of evaluation board to test and measure operation of**

**A1. Purpose**

This procedure explains the requirements for the proper handling, up, and testing of the Y5117P, to ensure the protection of the device.

**A2. Overview**

Certain conditions have to be met in order to test the functionality of this device. The Y5117P data sheet determines constraints, both temperature and power limitations involved in the testing and operation of the unit. These limitations must not be exceeded. Prolonged operation at elevated temperature or elevated power output can result in the failure of the device.

**A3. References**

All specifications are referenced against latest revision of the data sheet.

The **output ripple measurements** are measured using the 50 Ohms BNC

The **positive output voltage connections** are to this pin

The **output voltage measurement** is taken from the **output voltage sense pins**

**A4. Procedure**

**A4.1 Test Equipment**

Power supply should be capable of delivering a minimum of 20A and have the overvoltage protection. Loads must be 30A capable and operate at voltages down to 0.5V. Lead length between power supply and unit under test (UUT) and between UUT and load must be minimized, <1m is recommended.

Additional input capacitance may be required under specific conditions. The amount of capacitance required is a factor of input impedance, input voltage, input voltage regulation, and output current.

**A4.2 Connection of Test Equipment**

Pgnd is the common device ground pin. The input and output ground connections are connected to this pin.

Optional components on Y5117P evaluation card

The **input and output ground connection** is to this pin

**VLDO input** (for operation <5.2V)

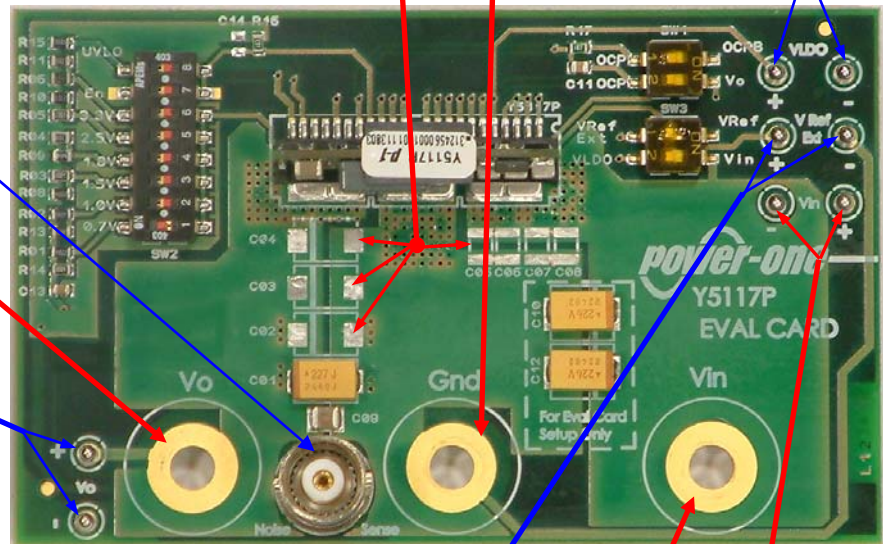

The **input positive voltage connection** is to this pin

Optional **external voltage reference** input (for below 1.3V)

**Input voltage sense** measurements taken from the input voltage sense pins



#### **A4.3 Default Settings / User Adjustments of SW1, SW2, SW3 and Optional Components**

To activate device (ENABLE), set SW2 Pin 7 to OFF position, to disable the unit set Pin 7 to ON.

When operating from an input voltage higher than 5.2V, SW3 Pin 2 should be set to ON. Otherwise, SW3 Pin 1 should be set to OFF and an external voltage source higher than 5.2V needs to be connected to  $V_{LDO}$  pins (P9 and P10 in the schematic). This voltage must not exceed 15V and be capable of supplying 60mA.

To adjust OCP (overcurrent protection) value (default ~22A) set SW1 Pin 1 and Pin 2 to ON position, then place a 0805 resistor on pad R17 and a 0805 capacitor on pad C11. Refer to the OCP adjustment section of the data sheet for the required value of the resistor and the capacitor.

The output voltage of 1.3V (factory default) requires SW2 Pins 1 to 6 to be switched OFF.

To change the output voltage to 3.3V, 2.5V, 1.8V, or 1.5V, a single switch needs to be set ON of SW2 Pins 6 to 3 respectively.

NOTE: only one switch from Pin 6 to Pin 1 can be set ON at any one time.

If a voltage higher than 1.3V not referred to above is required, then set SW2 Pin 6 to ON and replace R11 and/or R6 with resistors required to achieve the desired output. Refer to the output voltage adjustment section of the data sheet for value of resistor(s) required.

To achieve an output voltage of less than 1.3V, SW3 Pin 1 is set to ON, then 0.7V or 1.0V can be selected with SW2, Pin 1 or 2 respectively.

If a voltage lower than 1.3V not referred to above is required, then set SW3 Pin 1 to ON, SW2 pin 1 to ON and replace resistors R14 and/or R01 with resistors required to achieve the desired output. Refer to the output voltage adjustment section of the data sheet for value of resistor(s) required.

External reference voltage can be used to increase accuracy of the output voltage settings. Set SW3 Pin 1 to OFF and connect the external reference voltage to V Ref Ext pins (P13 and P14).

#### **A4.4 Turn-on Procedure**

Set the input power supply OVP (overvoltage protection) to 15V to ensure no damage to the Y5117P on the evaluation board will occur. Ensure the input voltage sense leads are connected to the evaluation board terminals to provide proper regulation and input voltage stability.

Start the input power supply at no load and 0V and increase voltage to desired input voltage, then turn on load (preferably half load initially).

In normal operation, the Y5117P is powered from a 12V front end or high-grade benches supply, with minimal lead or track length. If the output impedance of the input source is too high for the test setup, then the unit may fail to start. A low impedance (Low ESR) capacitor is then recommended between  $V_{in}$  and P<sub>gnd</sub> for optimum setup (as close to  $V_{in}$  as possible).

#### **A4.5 Measurements**

Input voltage measurements should be taken at  $V_{in}$  sense pins (+ & -) to improve accuracy. Output voltage should be measured at  $V_o$  sense pins (+ & -).

Standard shunts should be used for current measurements.

Noise is measured on BNC with a standard scope lead (50 Ohm) 20MHz bandwidth.

Minimize all lead lengths for input and output (to reduce impedance).

Capacitors C01, C10 and C12 are optional and used only for the evaluation board test setup and measurements (transients, etc.).



**A5. Evaluation board schematic and bill of material**

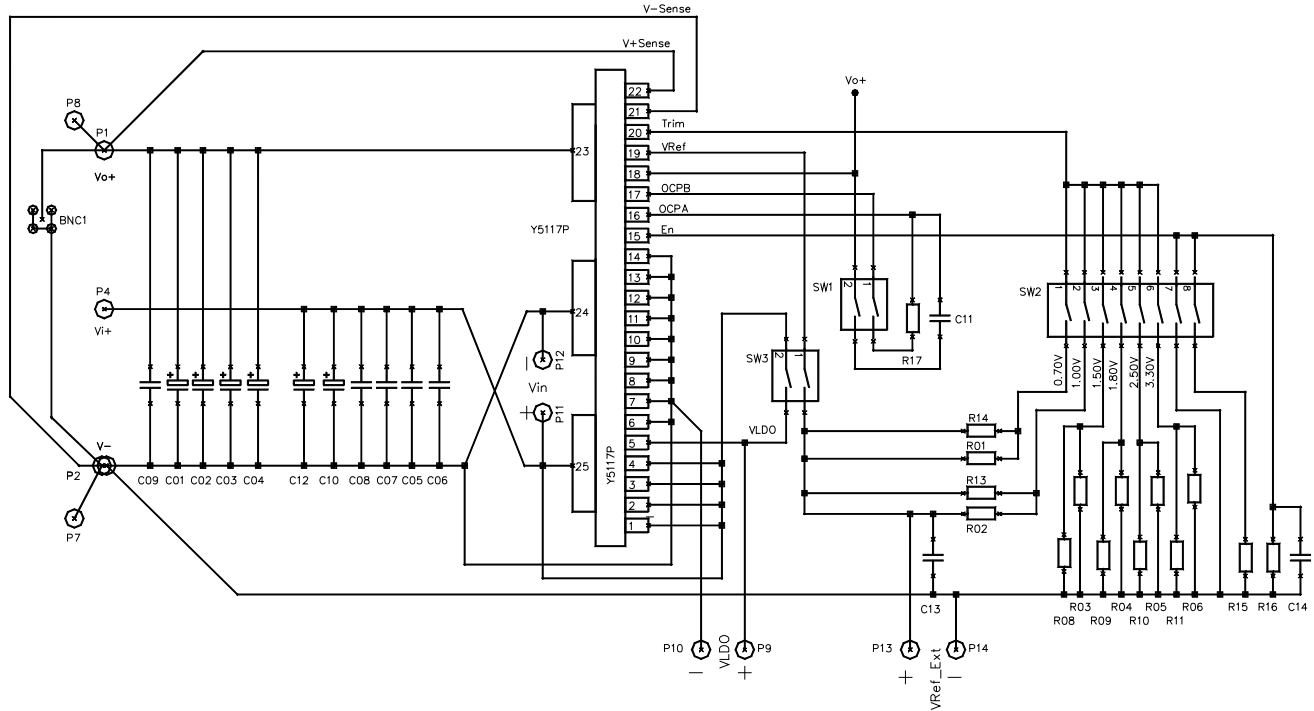

**Figure 16. Evaluation board schematic**

**Table 3. BOM of the evaluation board**

Reference Designator	Vendor	Description	Part Number	Qty
POL	Power-One	POL DC-DC CONVERTER	Y5117P	1
SW1		8 way, SMT, DIP Switches		1
SW2, SW3		2 way, SMT, DIP Switches		2
R01...R14		0805, +/-1%		14
R15,R17		Optional, 0805, +/-1%		
R16		0805, 10kOhm		1
C01		Tantalum Capacitor 220µF / 10V, 20%, D, Low ESR		1
C02...C04		Optional Tantalum Capacitor 10V, D, Low ESR		
C10, C12		Tantalum Capacitor 220µF / 35V, 20%, D, Low ESR		2
C05..C08		Optional 25V, X7R, 1210		
C09		10µF, 10V, +/-10%, X7R, 1210		1
C11, C14		Optional, 50V, X7R, 0805		
C13		1µF, 10V, X7R, ±10%, 0805		1